

Search our  
online catalog  
[www.mydata.com](http://www.mydata.com)

# Spare Parts

For MYDATA SMD Placement machines  
1, 2007

For a fast changing world

**MYDATA**<sup>®</sup>

# Contents

Centering System	2
Computer System	10
Conveyor System	36
Documentation	56
Feeder System	60
Framework	116
Glue System	122
HYDRA System	124
In-line System	132
Midas System	144
Peripheral Accessories	152
Placement Tools	154
Power Supply System	158
Service Tools	166
Software Products and Options	172
Spare Part Kits	174
Tray Handling System	178
Vacuum System	190
Vision System	200
X System	206
Y System	238
Z/Fi System	246

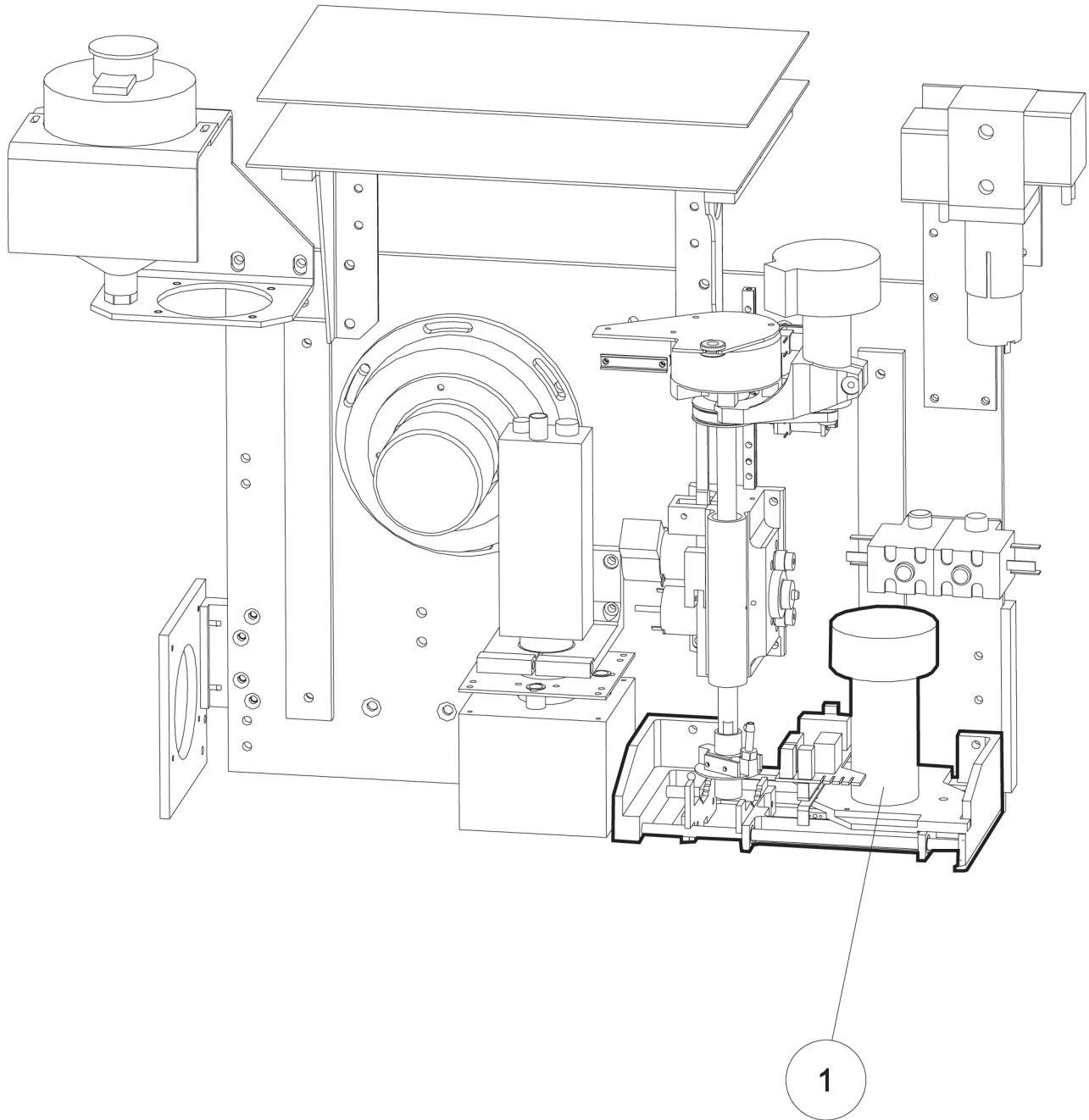

### Centering unit C60 complete



**Position:** 1

**Type of part:**  
Unit

**Part is replacing:**  
L-022-0002B

**Machine type:**

MY12 , MY15 , MY19 , MY9 , TP11 , TP12 , TP18 , TP9-3 , TP9-4

<b>Part no.</b>	<b>Product name</b>
L-022-0002C	Centering unit C60 complete

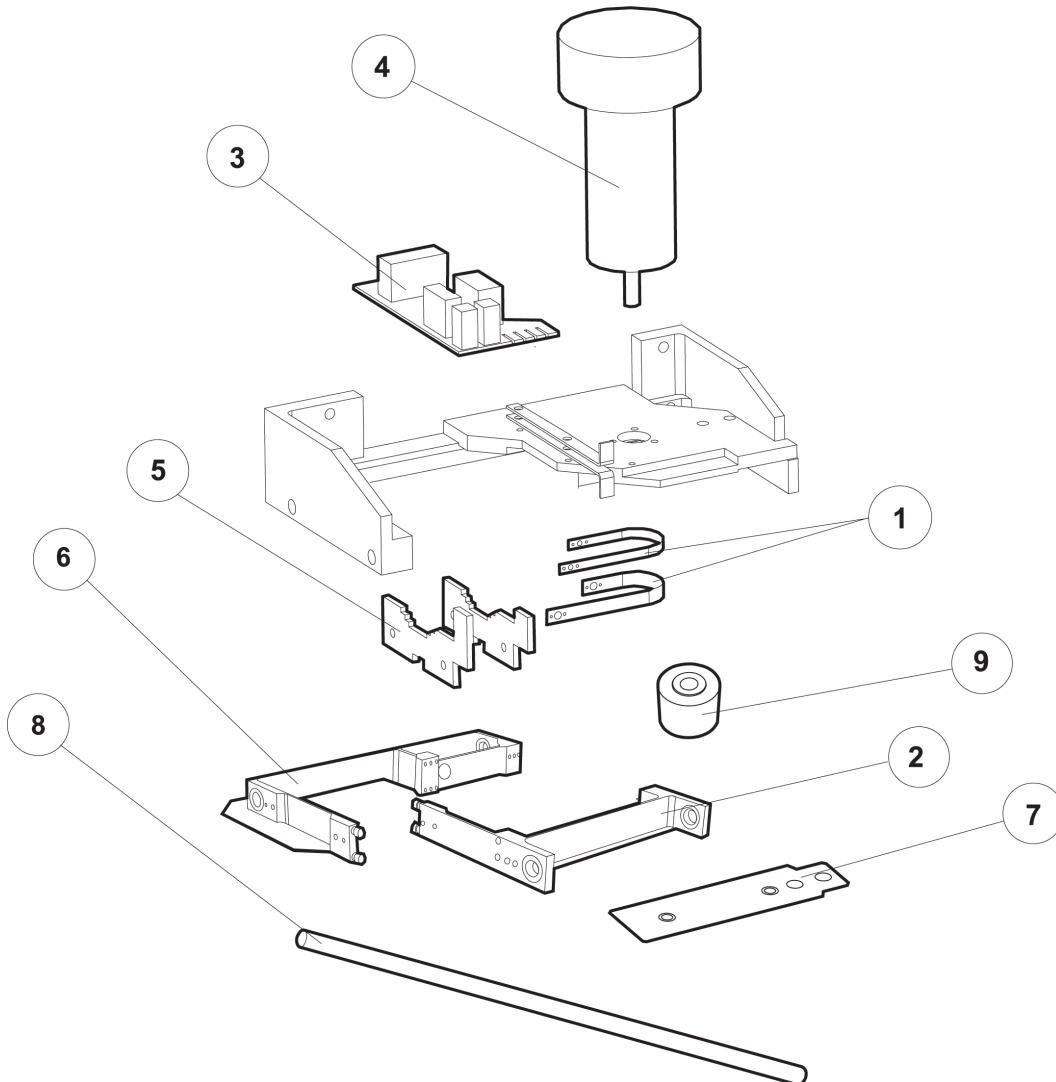
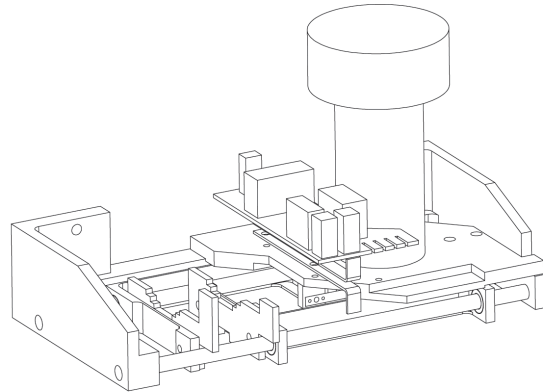

### C60 steel belt repair kit

**Position:** 1

**Type of part:**  
Kit

**Part is replacing:**  
D-022-0027-4 D-022-0028B-3

**Description**  
Kit with one steelbelt with hole and two steelbelts without hole delivered in a plastic box.

**Machine type:**  
TP9-3 , TP9-4 , TP11 , TP12 , TP18 , MY9 , MY12 , MY15 , MY19

Part no.	Product name
L-022-0008	C60 steel belt repair kit

### Inner jaw C-60



**Position:** 2  
**Type of part:**  
Mechanical component

**Machine type:**  
MY12 , MY15 , MY19 , MY9 , TP11 , TP12 , TP18 , TP9-3 , TP9-4

**Requirements:**  
Steel-belt centering device - L-022-0002C.

Part no.	Product name
L-022-0007	Inner jaw C-60

### CMB2 Ed-1E



**Position:** 3  
**Type of part:**  
PCB

**Description**  
Contains C motor RC-filter and connector for C encoder. This board can only be used with the new HEDL5xxx encoder, not with the old HEDS6xxx. Mechanically adjusted for Midas-unit.

**Machine type:**  
MY12 , MY15 , MY19 , MY9 , TP11 , TP12 , TP18 , TP9-3 , TP9-4

Part no.	Product name
L-029-0371-1E	CMB2 Ed-1E

### C-motor C-60 with CMB2-board



**Position:** 4  
**Type of part:**  
Kit  
**Part is replacing:**  
L-029-0169

**Description**  
This includes C-motor with HP HEDL-5560 type of transducer and CMB2-board. When replacing C-motor L-029-0169 it is also necessary to replace CMB-board with a CMB2 board.

**Machine type:**  
MY12 , MY15 , MY19 , MY9 , TP11 , TP9-3 , TP9-4

**Requirements:**  
C-60 centering with HP HEDS-6310 transducer on C-motor(L-029-0169) and CMB-board.

Part no.	Product name
L-029-0404	C-motor C-60 with CMB2-board

### Centering electrodes for C60



**Position:** 5  
**Type of part:**  
Miscellaneous

**Machine type:**  
MY12 , MY15 , MY19 , MY9 , TP11 , TP12 , TP18 , TP9-3 , TP9-4

Part no.	Product name
L-029-0175B	Centering electrodes for C60

### Outer jaw C-60



**Position:** 6  
**Type of part:**  
Mechanical component

**Machine type:**  
MY12 , MY15 , MY19 , MY9 , TP11 , TP12 , TP18 , TP9-3 , TP9-4



**Requirements:**

Steel-belt centering device - L-022-0002C.

Part no.	Product name
L-022-0006	Outer jaw C-60

**Steel belt cover C-60**



**Position:** 7  
**Type of part:**  
 Mechanical component

**Machine type:**

MY12 , MY15 , MY19 , MY9 , TP11 , TP12 , TP18 , TP9-3 , TP9-4

Part no.	Product name
D-022-0122-3	Steel belt cover C-60

**Axle C-60 centering device**



**Position:** 8  
**Type of part:**  
 Mechanical component

**Machine type:**

MY12 , MY15 , MY19 , MY9 , TP11 , TP12 , TP18 , TP9-3 , TP9-4

Part no.	Product name
D-022-0013B-3	Axle C-60 centering device

**Drive wheel C-60**



**Position:** 9  
**Type of part:**  
 Mechanical component

**Description**

Steel belt drive wheel for C-60 centering device.

**Machine type:**

TP9-3 , TP9-4 , TP11 , TP12 , TP18 , MY9 , MY12 , MY15 , MY19

Part no.	Product name
D-022-0121-3	Drive wheel C-60

**XCMC C-motor cable**



**Type of part:**  
 Cable

**Description**

Cable between XCAB-connector on CMB-board and XCM-connector on XWB(x)-board.

**Machine type:**

MY12 , MY15 , MY19 , MY9 , TP11 , TP12 , TP18 , TP9-3 , TP9-4

Part no.	Product name
L-029-0149	XCMC C-motor cable

**XTC cable**



**Type of part:**  
 Cable

**Description**

Cable between XTC-connector on CMB-board and XTC-connector on 3PT1-board.

**Machine type:**

MY12 , MY15 , MY19 , MY9 , TP11 , TP12 , TP18 , TP9-1 , TP9-2 , TP9-3 , TP9-4

Part no.	Product name
L-029-0150B	XTC cable

### XTP two/three test cable



**Type of part:**  
Cable

**Description**

Cable between XWB(x) board and 3PT1 board.

**Machine type:**

MY12 , MY15 , MY19 , MY9 , TP11 , TP12 , TP18 , TP9-1 , TP9-2 , TP9-3 , TP9-4

Part no.	Product name
L-019-0084	XTP two/three test cable

Part no.	Product name
L-019-0081D	Centering electrodes upgrade

### Centering steel belt repair kit

**Type of part:**  
Kit

**Part is replacing:**

D-012-0276-4 D-012-0278-4

**Description**

Kit with one steelbelt with hole and one steelbelt without hole delivered in a plastic box.

**Machine type:**

TP9-1 , TP9-2

Part no.	Product name
L-012-0133	Centering steel belt repair kit

### Centering axle bearing



**Type of part:**  
Kit

**Description**

Kit for refurbishing axles/bearings on a centering device - L-012-0006C.

**Machine type:**

TP9-1 , TP9-2

Part no.	Product name
L-012-0058	Centering axle bearing

### Centering unit cover, bottom



**Type of part:**  
Mechanical component

**Description**

Cover under the centering unit.

**Machine type:**

TP9-1 , TP9-2

**Requirements:**

Steel-belt centering device - L-012-0006C.

Part no.	Product name
D-012-0428-3	Centering unit cover, bottom

### Centering electrodes upgrade



**Type of part:**  
Kit

**Description**

Order centering electrodes - L-019-0490 after upgrade.

**Machine type:**

TP9-1 , TP9-2

**Requirements:**

Steel-belt centering device - L-012-0006C.

### Centering electrodes w/o cable

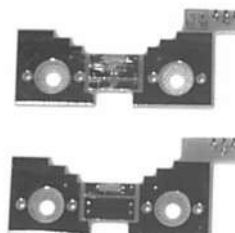

**Type of part:**  
Miscellaneous



**Machine type:**  
TP9-1 , TP9-2

**Requirements:**  
Only for machines without electrical test

Part no.	Product name
L-019-0476-5B	Centering electrodes w/o cable

### XTC electrodes with cables



**Type of part:**  
Miscellaneous

**Description**  
Centering unit has to be upgraded with TCB-board before using these centering electrodes. If not upgraded use Item Number - L-019-0081D.

**Machine type:**  
TP9-1 , TP9-2

**Requirements:**  
Steel-belt centering device - L-012-0006C.

Part no.	Product name
L-019-0490	XTC electrodes with cables

### XTC for belt centering unit



**Type of part:**  
Miscellaneous

**Machine type:**  
TP9-1

**Requirements:**  
Belt centering unit.

Part no.	Product name
L-019-0081C	XTC for belt centering unit

### TCB



**Type of part:**  
PCB

**Machine type:**  
TP9-1 , TP9-2

**Requirements:**  
Steel-belt centering device - L-012-0006C.

Part no.	Product name
L-019-0486-1	TCB

### C-motor with console



**Type of part:**  
Unit

**Description**  
Steel belt wheel glued on the motor shaft so this whole unit has to be ordered when replacing C-motor.

**Machine type:**  
TP9-1 , TP9-2

**Requirements:**  
Steel-belt centering device - L-012-0006C.

Part no.	Product name
L-012-0055	C-motor with console

### Centering unit complete



**Type of part:**  
Unit

**Machine type:**  
TP9-1 , TP9-2

**Requirements:**  
XWB ed. 4 or later version.

Part no.	Product name
L-012-0006C	Centering unit complete

### Steel belt centering upgrade

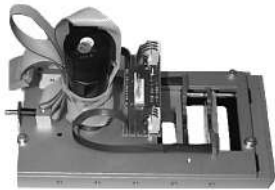

**Type of part:**  
Update kit

#### Description

Upgrade kit for upgrading from belt centering unit to steel-belt centering unit.

#### Machine type:

TP9-1

#### Requirements:

SYS 2.9, XWB ed. 4 or later version.

Part no.	Product name
L-012-0057	Steel belt centering upgrade

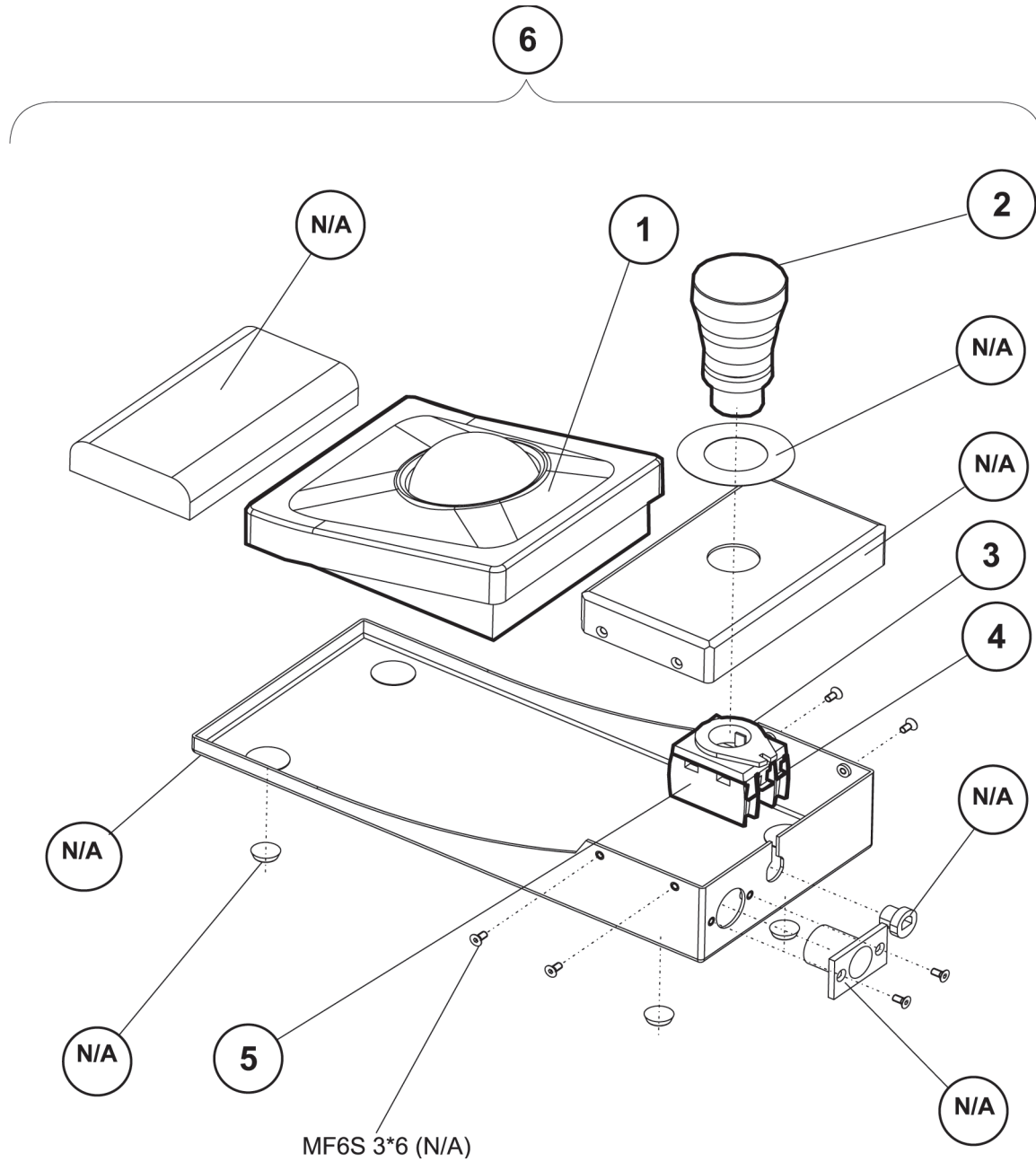

### Trackball

Position: 1

Type of part:  
Unit

Part is replacing:  
K-019-0019

Machine type:  
TP9-1, TP9-2, TP9-3, TP9-4, TP11, TP12, TP18, MY9, MY12, MY15, MY19

Part no.	Product name
K-019-0384	Trackball

Part no.	Product name
E-011-0011	Safety switch plate

### Safety switch contact block

Position: 4

Type of part:  
Electrical component



Machine type:  
MY9, MY12, MY15, MY19

Part no.	Product name
E-011-0012	Safety switch contact block

### Safety Button



Position: 2

Type of part:  
Electrical component

Part is replacing:  
E-011-0025

Machine type:  
MY12, MY15, MY19, MY9, TP9-2

Part no.	Product name
E-011-0026	Safety Button

### Safety switch contact block

Position: 5

Type of part:  
Electrical component



Machine type:  
MY9, MY12, MY15, MY19

Part no.	Product name
E-011-0013	Safety switch contact block

### Safety switch plate



Position: 3

Type of part:  
Electrical component

Machine type:  
MY9, MY12, MY15, MY19

### Trackball with emergency button



Position: 6

Type of part:  
Unit

Part is replacing:  
L-049-0085

Machine type:  
MY9, MY12, MY15, MY19

Part no.	Product name
L-049-0085B	Trackball with emergency button

### BM3CB with R6



#### Description

Connects the BM3 to all the cables coming in to the computer box 2.

- Generates +5V and +5.6V.
- Monitors the +/-25V.
- Converts differential encoder signals to single ended signals.
- Generates the Reset signal.
- Some fuses and EMI filters.

#### Requirements:

Computer Box 2.

Part no.	Product name
L-049-0088	BM3CB with R6 for MY-series
L-019-0753	BM3CB with R6 TP9-2U
L-019-0692	BM3CB with R6 for TP9-4/11
L-019-1001	BM3CB with R6 for TP9-4/11 HYDRA

### Dsub 25-pole - modular 6/6 adapter



#### Description

Adapter to convert RS232 modular 6/6 to DSUB 25 pole female.

#### Requirements:

TPSys

Part no.	Product name
L-019-0513B	D25F DSUB-25 F mod. 6/6 straight
L-019-0514B	D25FX DSUB-25 F mod. 6/6 cross
L-019-0481	RS232 DSUB25M modular 6/6 adapter

### Dsub 9-pole - modular 6/6 adapter



#### Description

Adapter to convert RS232 modular 6/6 to DSUB 9 pole female.

#### Requirements:

TPSys

Part no.	Product name
L-019-0511B	D9F DSUB-9 F mod. 6/6 straight
L-019-0512B	D9FX DSUB-9 F mod. 6/6 cross
L-019-0497B	D9M DSUB9M MODULAR 6/6

### SKB3 key-tops

Stop	
Esc	Enter
Shift	Toggle
Glue Mount	Trim
Toggle Pin Camera	Grab/Release Front/Back
PgUp	PgDn
↑	↓
Backspace ←	→
Esc	Enter

#### Requirements:

TPSys 1.5 or later.

Part no.	Product name
L-019-0493-EN	SKB3 key-tops, English
L-019-0493-DA	SKB3 key-tops, Danish
L-019-0493-DU	SKB3 key-tops, Dutch
L-019-0493-FI	SKB3 key-tops, Finnish
L-019-0493-FR	SKB3 key-tops, French
L-019-0493-GE	SKB3 key-tops, German

Part no.	Product name
L-019-0493-IT	SKB3 key-tops, Italian
L-019-0493-NO	SKB3 key-tops, Norwegian
L-019-0493-SP	SKB3 key-tops, Spanish
L-019-0493-SW	SKB3 key-tops, Swedish

### SKB4 key-tops

PgUp		Stop
PgDn	Glue Mount	Trim
Toggle Pin Camera		Magazine
Chair Status Leave Top	Unload Load	Grab/Release Front/Back
7	& 8	* 9
- 4	- 5	+ 6
# 1	/ 2	@ 3
↑	0	Toggle
↓	Backspace	→
Shift	Esc	Enter

**Requirements:**  
TPSys 1.5 or later.

Part no.	Product name
L-029-0318-EN	SKB4 key-tops, English
L-029-0318-DE	SKB4 key-tops, Danish
L-029-0318-DU	SKB4 key-tops, Dutch
L-029-0318-FI	SKB4 key-tops, Finnish
L-029-0318-FR	SKB4 key-tops, French
L-029-0318-GE	SKB4 key-tops, German
L-029-0318-IT	SKB4 key-tops, Italian
L-029-0318-NO	SKB4 key-tops, Norwegian
L-029-0318-SP	SKB4 key-tops, Spanish
L-029-0318-SW	SKB4 key-tops, Swedish

### Digitizer cable



**Type of part:**  
Cable

**Machine type:**  
TP9-1 , TP9-2

**Requirements:**  
SYS 2.9

Part no.	Product name
L-019-0214	Digitizer cable

### Digitizer cable Oce Graphics



**Type of part:**  
Cable

**Description**  
For Oce' Graphics 6400 Series. Connected from Digitizer connector on P4/CP2 to the Digitizer original cable.

**Machine type:**  
TP9-1 , TP9-2

**Requirements:**  
SYS 2.9

Part no.	Product name
L-019-0214B	Digitizer cable Oce Graphics

### Frame grabber cable



**Type of part:**  
Cable

**Description**  
Connected on the Framgrabber 15-pole D-sub. 'Video In' connected to 'Output 0' on Video Multi-Plexor Board. 'Video Out' connected to Monitor 1 'Input B'.

**Machine type:**  
TP9-1 , TP9-2

**Requirements:**  
SYS 2.9

Part no.	Product name
L-019-0436	Frame grabber cable



### IDE to SCSI Converter



**Type of part:**  
Cable

**Machine type:**  
MY9 , MY12 , MY15 , MY19

Part no.	Product name
K-049-0009	IDE to SCSI Converter

Part no.	Product name
L-049-0039	Keyboard cable extender

### Keyboard extension cable



**Type of part:**  
Cable

**Description**  
Cable between keyboard and machine. 6.10 meters long.

**Machine type:**  
TP9-1 , TP9-2 , TP9-3 , TP9-4 , TP11 , TP12 , TP18

**Requirements:**  
TPSys

Part no.	Product name
L-019-0477	Keyboard extension cable

### JFKB full keyboard cable



**Type of part:**  
Cable

**Description**  
For JFKB joystick full keyboard - L-019-0055-1.

**Machine type:**  
TP9-1 , TP9-2

**Requirements:**  
SYS 2.9

Part no.	Product name
L-019-0096	JFKB full keyboard cable

### MDA/VGA cable for BIOS check



**Type of part:**  
Cable

**Machine type:**  
TP11 , TP12 , TP18 , TP9-1 , TP9-2 , TP9-3 , TP9-4

**Requirements:**  
CP4-board.

Part no.	Product name
L-019-0909	MDA/VGA cable for BIOS check

### Keyboard cable extender



**Type of part:**  
Cable

**Description**  
Cable between keyboard and machine. 7 meters long.

**Machine type:**  
MY12 , MY15 , MY19 , MY9

### Monitor cable adapter



**Type of part:**  
Cable

**Description**

For monochrome monitor (K-019-0147). Cable from CP4 to monitor.

**Machine type:**

TP9-1 , TP9-2 , TP9-3 , TP12 , TP18

**Requirements:**

TPSys

Part no.	Product name
----------	--------------

L-019-0479	Monitor cable adapter
------------	-----------------------

**Machine type:**

TP9-1 , TP9-2

**Requirements:**

SYS 2.9

Part no.	Product name
----------	--------------

L-019-0327B	PC - PC 25 pole cable
-------------	-----------------------

**Multi-port serial board cable**



**Type of part:**  
Cable

**Description**

For Multi-port serial board - K-019-0189.

**Machine type:**

TP9-1 , TP9-2 , TP9-3 , TP9-4 , TP11 , TP12 , TP18

Part no.	Product name
----------	--------------

K-019-0190	Multi-port serial board cable
------------	-------------------------------

**PC - TP9 25 pole cable**



**Type of part:**  
Cable

**Machine type:**

TP9-1 , TP9-2

**Requirements:**

SYS 2.9

Part no.	Product name
----------	--------------

L-019-0326B	PC - TP9 25 pole cable
-------------	------------------------

**RGB monitor cable 1**



**Type of part:**  
Cable

**Description**

Cable from CP4 to RGB monitor.

**Machine type:**

TP9-1 , TP9-2 , TP9-3 , TP9-4 , TP11 , TP12 , TP18

**Requirements:**

TPSys, CP4.

Part no.	Product name
----------	--------------

L-019-0519	RGB monitor cable 1
------------	---------------------

**Parallel Port to SCSI cable**

**Type of part:**

Cable

**Machine type:**

TP9-1 , TP9-2 , TP9-3 , TP9-4 , TP11 , TP12 , TP18

Part no.	Product name
----------	--------------

K-010-0344	Parallel Port to SCSI cable
------------	-----------------------------

**PC - PC 25 pole cable**



**Type of part:**  
Cable

**RGB monitor cable 2**



**Type of part:**  
Cable

**Description**

Cable between RGB monitors.

**Machine type:**

TP9-1 , TP9-2 , TP9-3 , TP9-4 , TP11 , TP12 , TP18

**Requirements:**

TPSys, CP4

Part no.	Product name
L-019-0520	RGB monitor cable 2

**RS 232 modular cable**

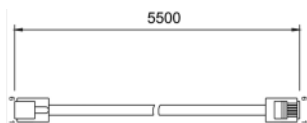

Type of part:  
Cable

**Description**

RS232 cable used for peripheral accessories such as barcode reader and digitizer.

**Machine type:**

TP9-1 , TP9-2 , TP9-3 , TP9-4 , TP11 , TP12 , TP18

**Requirements:**

TPSys

Part no.	Product name
L-019-0482	RS 232 modular cable

**Safety loop extension cable**

**Type of part:**

Cable

**Machine type:**

MY9 , MY12 , MY15 , MY19

Part no.	Product name
L-049-0113	Safety loop extension cable

**VGA-VGA Adaptor Cable for VVG2**



Type of part:  
Cable

**Description**

May be needed when installing an AT-CPU with VVG2 in a machine that previously had an AT-CPU with VVG. Due to problems fitting video cables on VVG2 this adaptor is needed.

**Machine type:**

TP9-4 , TP11

Part no.	Product name
L-049-0175	VGA-VGA Adaptor Cable for VVG2

**XCR21 monitor cable TP9-BNC**



Type of part:  
Cable

**Machine type:**

TP9-1

**Requirements:**

SYS 2.9

Part no.	Product name
L-019-0102	XCR21 monitor cable TP9-BNC

**XCR21 Monitor cable TP9-BNC**



Type of part:  
Cable

**Description**

Cable from AT-CPU to monitor.

**Machine type:**

TP9-2

**Requirements:**

TPSys

Part no.	Product name
L-019-0415	XCR21 Monitor cable TP9-BNC

### XCR22 Monitor cable BNC-BNC



Type of part:  
Cable

**Machine type:**

TP9-1 , TP9-2 , TP9-3 , TP12 , TP18

**Requirements:**

SYS 2.9 or TPSys with B/W monitors.

Part no.	Product name
L-019-0103	XCR22 Monitor cable BNC-BNC

### XDD1 Cable

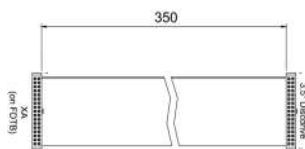

Type of part:  
Cable

**Machine type:**

MY12 , MY15 , MY19 , MY9 , TP11 , TP9-4

Part no.	Product name
L-049-0125	XDD1 Cable

### XDDP disk drive cable



Type of part:  
Cable

**Description**

With this cable the A: drive will be 3,5".

**Machine type:**

TP12 , TP18

Part no.	Product name
L-029-0347	XDDP disk drive cable

### XDDP disk drive cable A:5,25

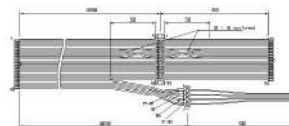

Type of part:  
Cable

**Description**

With this cable the A: drive will be 5,25".

**Machine type:**

TP9-1 , TP9-2 , TP9-3

Part no.	Product name
L-019-0473	XDDP disk drive cable A:5,25

### XDDP diskdrive cable

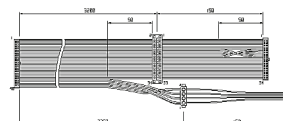

Type of part:  
Cable

**Description**

With this cable the A: drive will be 3,5".

**Machine type:**

TP9-1 , TP9-2 , TP9-3 , TP9-4 , TP11

Part no.	Product name
L-019-0801	XDDP diskdrive cable

### XDDP diskdrive cable

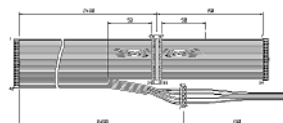

Type of part:  
Cable

**Description**

With this cable the A: drive will be 5,25".

**Machine type:**

TP9-4 , TP11

**Requirements:**

CP4-board

Part no.	Product name
L-019-0620	XDDP diskdrive cable

**XDDP diskdrive cable**

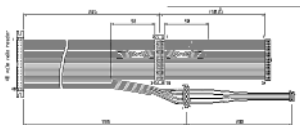

Type of part:  
Cable

**Description**

With this cable the A: drive will be 5,25".

**Machine type:**

TP12, TP18

**Part no.**

**Product name**

L-029-0050B

XDDP diskdrive cable

**XDDP1 diskdrive cable**

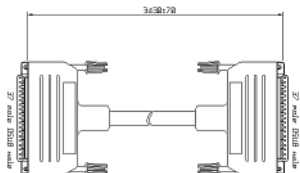

Type of part:  
Cable

**Description**

With this cable the A: drive will be 3,5".

**Machine type:**

TP9-4, TP11

**Requirements:**

CP5-board

**Part no.**

**Product name**

L-019-0765

XDDP1 diskdrive cable

**XDY diskette cable in Y Wagon**

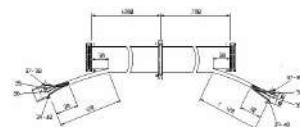

Type of part:  
Cable

**Machine type:**

TP9-2

**Requirements:**

SYS 2.9

**Part no.**

**Product name**

L-019-0416

XDY diskette cable in Y Wagon

**XFT-board position sensor**

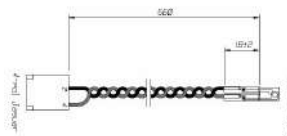

Type of part:  
Cable

**Machine type:**

MY12, MY15, MY19, MY9, TP11, TP12, TP18, TP9-1, TP9-2, TP9-3, TP9-4

**Requirements:**

270, 450, 420, 400PT, 500T or 500T2 Conveyor.

**Part no.**

**Product name**

L-019-0252

XFT-board position sensor

**XM XO-X6 cable**

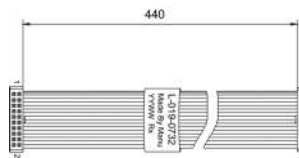

Type of part:  
Cable

**Machine type:**

MY12, MY15, MY19, MY9, TP11, TP9-2, TP9-4, Tray Exchanger

**Part no.**

**Product name**

L-019-0732

XM XO-X6 cable

**XOCAT OCL & video cable**

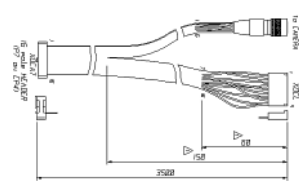

Type of part:  
Cable

Part is replacing:  
L-019-0499

**Description**

Cable from CP4 to Optical centering camera.

**Machine type:**

TP9-1, TP9-2

Part no.	Product name
L-019-0499B	XOCAT OCL & video cable

### XOCP-1 opt. cent. power cable 1

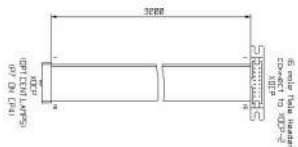

**Type of part:**  
Cable

**Part is replacing:**  
L-019-0470

#### Description

Cable from CP4 to Optical centering power cable 2 (L-019-0471).

#### Machine type:

TP9-3 , TP9-4 , TP11

Part no.	Product name
L-019-0470B	XOCP-1 opt. cent. power cable 1

### XOCP-2 opt. cent. power cable 2

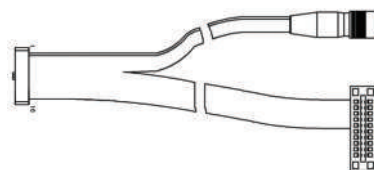

**Type of part:**  
Cable

#### Description

Cable from Optical centering power cable 1 (L-019-0470B) to Optical centering camera.

#### Machine type:

TP9-3 , TP9-4 , TP11

Part no.	Product name
L-019-0471	XOCP-2 opt. cent. power cable 2

### XPD disk power & data cable



**Type of part:**  
Cable

#### Machine type:

TP9-1

#### Requirements:

SYS 2.9

Part no.	Product name
L-019-0092	XPD disk power & data cable

### XPD disk power & data cable

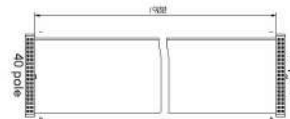

**Type of part:**  
Cable

#### Machine type:

TP9-2

#### Requirements:

SYS 2.9

Part no.	Product name
L-019-0413	XPD disk power & data cable

### XPOA-OCL cable

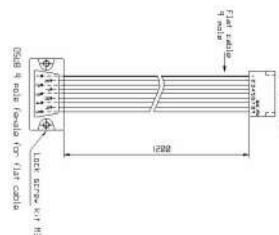

**Type of part:**  
Cable

#### Machine type:

TP9-1 , TP9-2

#### Requirements:

Vision. SYS 2.9.

Part no.	Product name
L-019-0315	XPOA-OCL cable

### XPOW1 Cable

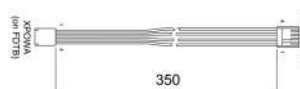

**Type of part:**  
Cable

#### Machine type:

MY12 , MY15 , MY19 , MY9 , TP11 , TP9-4



Part no.	Product name
L-049-0123	XPOW1 Cable

### XSKB keyboard cable



**Type of part:**  
Cable

**Part is replacing:**  
L-019-0091

**Machine type:**  
TP9-1 , TP9-2 , TP9-3

Part no.	Product name
L-019-0424	XSKB keyboard cable

### XYBO/80V Y Booster2 80V 0.56 ohm cable

**Type of part:**  
Cable

**Machine type:**  
MY12 , MY15 , MY19 , MY9 , TP11 , TP9-4

Part no.	Product name
L-019-0772	XYBO/80V Y Booster2 80V 0.56 ohm cable

### XZBO/80V Z Booster2 80V 1ohm cable

**Type of part:**  
Cable

**Machine type:**  
MY12 , MY15 , MY19 , MY9 , TP11 , TP9-4

Part no.	Product name
L-019-0771	XZBO/80V Z Booster2 80V 1ohm cable

### DC/DC converter 25V cabled



**Type of part:**  
Electrical component

**Part is replacing:**  
VE9910005

### Machine type:

TP9-1 , TP9-2 , TP9-3 , TP9-4 , TP11 , TP12 , TP18

### Requirements:

Computer Box 1

Part no.	Product name
L-029-0429	DC/DC converter 25V cabled

### DC/DC converter without cables



**Type of part:**  
Electrical component

### Machine type:

MY12 , MY15 , MY19 , MY9 , TP11 , TP9-2 , TP9-4

### Requirements:

BM3CB board.

Part no.	Product name
E-991-0005	DC/DC converter without cables

### Fuse kit BM3CB

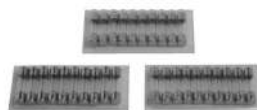

**Type of part:**  
Electrical component

### Description

10 pcs Fuse quick 2A 20mm  
10 pcs Fuse quick 4A 20mm  
10 pcs Fuse quick 1.6A 20mm

### Machine type:

MY12 , MY15 , MY19 , MY9 , TP11 , TP9-2 , TP9-4

Part no.	Product name
L-019-1003	Fuse kit BM3CB

### Keyboard US



**Type of part:**  
Electrical component

**Part is replacing:**  
K-019-0168

**Machine type:**

MY12 , MY15 , MY19 , MY9 , TP11 , TP12 , TP18 , TP9-1 , TP9-2 , TP9-3 , TP9-4

**Requirements:**

TPSys

Part no.	Product name
K-019-0018	Keyboard US

### Machine serial number circuit

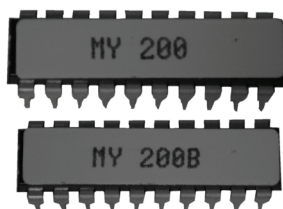

**Type of part:**  
Electrical component

**Part is replacing:**  
L-019-0179 + L-019-0179B

**Machine type:**

MY12 , MY15 , MY19 , MY9 , TP11 , TP12 , TP18 , TP9-1 , TP9-2 , TP9-3 , TP9-4

**Requirements:**

TPSys

**Ordering info:**

Please state serial number of machine and TPSys version when ordering.

Part no.	Product name
L-019-0179C	Machine serial number circuit

### PC disk drive 5 1/4"



**Type of part:**  
Electrical component

**Part is replacing:**  
K-019-0161

**Machine type:**

TP9-1 , TP9-2 , TP9-4 , TP11 , TP12 , TP18

**Requirements:**

TPSys

Part no.	Product name
K-019-0161B	PC disk drive 5 1/4"

### SNB serial number board



**Type of part:**

Electrical component

**Machine type:**

TP9-1 , TP9-2

**Requirements:**

SYS 2.9

**Ordering info:**

Please state serial number of machine when ordering.

Part no.	Product name
L-019-0159	SNB serial number board

### Tranzorb 24V 600W



**Type of part:**

Electrical component

**Description**

On Backplane Motherboard in Computer Box (L-019-0001-4, L-029-0267-1), BM3CB board (L-019-0692, L-019-0753, L-019-1001, L-049-0088) and DCRB Regulator board (L-029-0087-2B). SMBG24A DO215AB

**Machine type:**

MY12 , MY15 , MY19 , MY9 , TP11 , TP12 , TP18 , TP9-1 , TP9-2 , TP9-3 , TP9-4

Part no.	Product name
SSTRANZ24V600	Tranzorb 24V 600W

### ULN2065B darlington driver



**Type of part:**  
Electrical component

**Machine type:**  
TP9-1 , TP9-2 , TP9-3 , TP9-4 , TP11 , TP12 , TP18 , MY9 , MY12 , MY15 , MY19

**Requirements:**  
MI-board edition 6C

Part no.	Product name
SHULN2065B	ULN2065B darlington driver

### CD-ROM kit SCSI

**Type of part:**  
Kit

**Part is replacing:**  
L-010-0346

**Machine type:**  
TP9-1 , TP9-2 , TP9-3 , TP9-4 , TP11 , TP12 , TP18

Part no.	Product name
L-010-0347B	CD-ROM kit SCSI

### Disk drive 3.5" mount kit

**Type of part:**  
Kit

**Description**  
For machines not equipped with 3.5" disk drive.

**Machine type:**  
TP9-1 , TP9-2 , TP9-3 , TP9-4 , TP11 , TP12 , TP18

Part no.	Product name
L-019-0704	Disk drive 3.5" mount kit

### Hard drive WD800 BB

**Type of part:**  
Kit

**Part is replacing:**  
L-019-1089B

**Description**  
Will not work on Machines running on Venix OS and having Micronics motherboards with Mr. BIOS - BIOS. See - K-019-0197F.

**Machine type:**  
TP9-1 , TP9-2 , TP9-3 , TP9-4 , TP11 , TP12 , TP18 , MY9 , MY12 , MY15 , MY19

Part no.	Product name
L-019-1089C	Hard drive WD800 BB

### Hitachi 5K100 40GB

**Type of part:**  
Kit

**Description**  
For machines with 2.5" HD. If having 3.5" HD the AT-CPU has to be upgraded with L-019-1155 before using this HD as spare part.

**Machine type:**  
TP9-1 , TP9-2 , TP9-3 , TP9-4 , TP11 , TP12 , TP18 , MY9 , MY12 , MY15 , MY19

**Requirements:**  
2.5" HD.

Part no.	Product name
L-019-1156	Hitachi 5K100 40GB

### Key top F10 spare part kit

**Type of part:**  
Kit

**Machine type:**  
TP9-1 , TP9-2 , TP9-3 , TP9-4 , TP11 , TP12 , TP18 , MY9 , MY12 , MY15 , MY19

**Requirements:**  
TPSys 2.5

Part no.	Product name
L-041-0141	Key top F10 spare part kit

### MOD cable & DSUB 9 adapters



**Type of part:**  
Kit

**Description**

For Digitizer Calcomp 34180, Oce 4610. Note that cable supplied with digitizer is needed to be connected to digitizer.

**Machine type:**

MY12 , MY15 , MY19 , MY9 , TP11 , TP12 , TP18 , TP9-1 , TP9-2 , TP9-3 , TP9-4

Part no.	Product name
L-040-0089	MOD cable & DSUB 9 adapters

### Network card 3Com 3C905CX-TX-M spare part

**Type of part:**  
Kit

**Machine type:**

TP9-1 , TP9-2 , TP9-3 , TP9-4 , TP11 , TP12 , TP18 , MY9 , MY12 , MY15 , MY19

Part no.	Product name
L-019-0056	Network card 3Com 3C905CX-TX-M spare part

### Board guide rail



**Type of part:**  
Miscellaneous

**Machine type:**

MY12 , MY15 , MY19 , MY9 , TP11 , TP9-4 , Tray Exchanger

Part no.	Product name
L-019-0730	Board guide rail

### Disc Drive 3.5" Sony

**Type of part:**  
Miscellaneous

**Part is replacing:**  
K-019-0343B

**Machine type:**

TP9-1 , TP9-2 , TP9-3 , TP9-4 , TP11 , TP12 , TP18 , MY9 , MY12 , MY15 , MY19

Part no.	Product name
K-019-0343C	Disc Drive 3.5" Sony

### Disk drive for TP9



**Type of part:**  
Miscellaneous

**Description**

For 5,25" 2S/2D diskettes - K-011-0016.

**Machine type:**

TP9-1 , TP9-2

**Requirements:**

SYS 2.9

Part no.	Product name
K-019-0113	Disk drive for TP9

### Diskette 2S/2D 5.25"

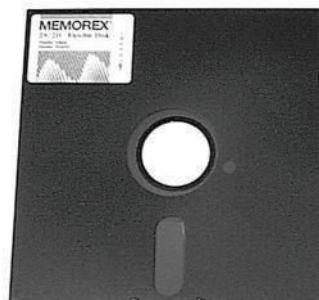

**Type of part:**  
Miscellaneous

**Machine type:**

TP9-1 , TP9-2

**Requirements:**

SYS 2.9

Part no.	Product name
K-010-0016	Diskette 2S/2D 5.25"

**DVD-rom drive SCSI**

**Type of part:**

Miscellaneous

**Part is replacing:**

K-031-0005

**Machine type:**

TP9-1 , TP9-2 , TP9-3 , TP9-4 , TP11 , TP12 , TP18 , MY9 , MY12 , MY15 , MY19

Part no.	Product name
K-031-0005B	DVD-rom drive SCSI

**Hard disk**



**Type of part:**  
Miscellaneous

**Description**

For Machines running on Venix OS and having Micronics motherboards with Mr. BIOS - BIOS. All other Machines use L-019-1089C.

**Machine type:**

TP11 , TP12 , TP18 , TP9-1 , TP9-2 , TP9-3 , TP9-4

**Requirements:**

TPSys 1.x, CP4

Part no.	Product name
K-019-0197F	Hard disk

**LCD Monitor**

**Type of part:**

Miscellaneous

**Machine type:**

MY9 , MY12 , MY15 , MY19

Part no.	Product name
K-040-0215	LCD Monitor

**Memory 32MEG EDO 60NS SIMM**



**Type of part:**  
Miscellaneous

**Machine type:**

MY12 , MY15 , MY19 , MY9 , TP11 , TP12 , TP18 , TP9-1 , TP9-2 , TP9-3 , TP9-4

Part no.	Product name
K-019-0348	Memory 32MEG EDO 60NS SIMM

**Thin components in box**

**Type of part:**

Miscellaneous

**Machine type:**

TP9-1 , TP9-2 , TP9-3 , TP9-4 , TP11 , TP12 , TP18 , MY9 , MY12 , MY15 , MY19

Part no.	Product name
L-012-0622	Thin components in box

**XFAN Fan with cable**



**Type of part:**  
Miscellaneous

**Description**

Papst 614. Computerbox fan for machine with AT-CPU.

**Machine type:**

TP9-1 , TP9-2 , TP9-3 , TP9-4 , TP12 , TP18

**Requirements:**

Computer Box 1.

Part no.	Product name
L-019-0397	XFAN Fan with cable

### ATC AT connector board

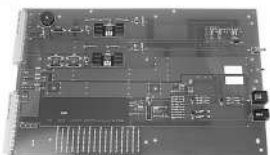

**Type of part:**  
PCB

**Machine type:**

TP11 , TP12 , TP18 , TP9-1 , TP9-2 , TP9-3 , TP9-4

**Requirements:**

Computer Box 1

Part no.	Product name
L-019-0317-1B	ATC AT connector board

### ATC2 AT connector board 2



**Type of part:**  
PCB

**Part is replacing:**  
L-019-0657-2B

**Description**

ATC2 supports the computer main board with -5V, +5V, -12V and +12V.

**Machine type:**

MY12 , MY15 , MY19 , MY9 , TP11 , TP9-2 , TP9-4

**Requirements:**

Computer box 2

Part no.	Product name
L-019-0657-2C	ATC2 AT connector board 2

### AT13 AT interconnect board 3



**Type of part:**  
PCB

**Part is replacing:**  
L-019-0660-1

**Machine type:**

TP9-1 , TP9-2 , TP9-4 , TP11 , TP12 , TP18

**Part no.**                      **Product name**

L-019-0660-1B	AT13 AT interconnect board 3
---------------	------------------------------

### Configured CPU-card with VGA



**Type of part:**  
PCB

**Part is replacing:**  
K-019-0358

**Machine type:**

MY12 , MY15 , MY19 , MY9 , TP11 , TP9-2 , TP9-4

**Requirements:**

CP5 or CP54.

Part no.	Product name
L-019-1059	Configured CPU-card with VGA

### Configured CPU-card without VGA



**Type of part:**  
PCB

**Part is replacing:**  
K-019-0357

**Machine type:**

TP11 , TP12 , TP18 , TP9-1 , TP9-2 , TP9-3 , TP9-4

**Requirements:**

CP4.

Part no.	Product name
L-019-1058	Configured CPU-card without VGA

### Configured MAT915

**Type of part:**  
PCB

**Description**

Configured CPU card MAT915 for 700 MHz CPU PF2 AT-CPUs.

**Machine type:**

TP9-1 , TP9-2 , TP9-3 , TP9-4 , TP11 , TP12 , TP18 , MY9 , MY12 , MY15 , MY19

Part no.	Product name
L-019-1146	Configured MAT915



### CP4 without front panel



Type of part:  
PCB

**Machine type:**

TP9-1 , TP9-2 , TP9-3 , TP9-4 , TP11 , TP12 , TP18

**Requirements:**

Computer box 1.

Part no.	Product name
L-019-1005-2A	CP4 without front panel

### CP4 without front panel



Type of part:  
PCB

**Machine type:**

TP9-2 , TP9-4 , TP11

**Requirements:**

Computer Box 2, BM3CB.

Part no.	Product name
L-019-0241-2A	CP4 without front panel

### CP5 central processor board 5



Type of part:  
PCB

Part is replacing:  
L-019-0803-3B

**Machine type:**

MY12 , MY15 , MY19 , MY9 , TP11 , TP9-4

**Requirements:**

TPSys 1.6 or later.

Part no.	Product name
L-019-0803-3C	CP5 central processor board 5

### CP54 edition 1C

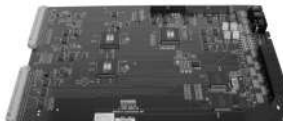

Type of part:  
PCB

**Description**

For machines upgraded with AT-CPU with CP54.

**Machine type:**

TP11 , TP12 , TP18 , TP9-1 , TP9-2 , TP9-3 , TP9-4

**Requirements:**

CP54

Part no.	Product name
L-019-1020-1C	CP54 edition 1C

### CPP CP5-ISA plug-in board edition 3

**Type of part:**

PCB

**Part is replacing:**

L-019-0719-2

**Description**

CPP is an ISA plugin board which connects CP5 to an ISA slot on the motherboard. CPP also holds the Hydra camera connector.

Same as CPP Ed-2, but added an internal 68 way wide SCSI connector to the SCSI converter

**Machine type:**

TP9-2 , TP9-4 , TP11 , MY9 , MY12 , MY15 , MY19

Part no.	Product name
L-019-0719-3	CPP CP5-ISA plug-in board edition 3

### FGB frame grabber board



Type of part:  
PCB

**Description**

SYS 2.9

**Machine type:**

TP9-1 , TP9-2

Part no.	Product name
L-019-0277-3B	FGB frame grabber board

### Frame grabber board

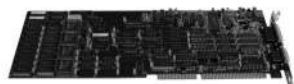

**Type of part:**  
PCB

**Machine type:**  
TP9-1 , TP9-2

**Requirements:**  
PC vision.

Part no.	Product name
K-019-0166	Frame grabber board

### Intel Pro/100+ spare part

**Type of part:**  
PCB

**Description**  
Network card

**Machine type:**  
TP9-1 , TP9-2 , TP9-3 , TP9-4 , TP11 , TP12 , TP18 , MY9 , MY12 , MY15 , MY19

Part no.	Product name
L-019-0030	Intel Pro/100+ spare part

### MGP card

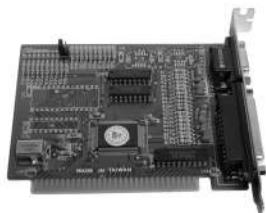

**Type of part:**  
PCB

**Part is replacing:**  
K-019-0157

**Machine type:**  
TP9-1 , TP9-2 , TP9-4 , TP11 , TP12 , TP18

Part no.	Product name
L-019-1017	MGP card

### MI-MOT1 unit



**Type of part:**  
PCB

**Part is replacing:**  
L-019-0059

**Machine type:**  
TP9-1 , TP9-2 , TP9-3 , TP9-4 , TP11 , TP12 , TP18

**Requirements:**  
Computer Box 1.

Part no.	Product name
L-019-0059C	MI-MOT1 unit

### MI-MOT1 unit with front panel



**Type of part:**  
PCB

**Machine type:**  
MY15 , MY19 , TP11 , TP12 , TP18 , TP9-2 , TP9-4

**Requirements:**  
Computer Box 2.

Part no.	Product name
L-019-0750	MI-MOT1 unit with front panel

### MI-MOT3 with front panel



**Type of part:**  
PCB

**Machine type:**  
MY9 , MY12 , MY15 , MY19

**Requirements:**  
See L-049-0162 MOT3 with front panel.

Part no.	Product name
L-049-0185	MI-MOT3 with front panel

### MI magazine interface board

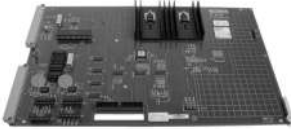

**Type of part:**  
PCB

**Part is replacing:**  
L-019-0049-5A

**Machine type:**

TP9-1 , TP9-2 , TP9-3 , TP9-4 , TP11 , TP12 , TP18

**Requirements:**

Computer Box 1.

Part no.	Product name
L-019-0049	MI magazine interface board

### MOT1 motor control board 1



**Type of part:**  
PCB

**Part is replacing:**  
L-019-0029-2H

**Machine type:**

TP9-1 , TP9-2 , TP9-3 , TP9-4 , TP11 , TP12 , TP18

**Requirements:**

Computer Box 1.

Part no.	Product name
L-019-0029	MOT1 motor control board 1

### MOT1 with front panel

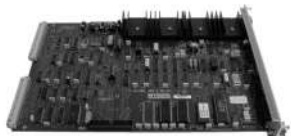

**Type of part:**  
PCB

**Description**

The motor controller controls the motor and has two encoder inputs and two motor outputs.

**Machine type:**

MY12 , MY15 , MY19 , MY9 , TP11 , TP9-2 , TP9-4

**Requirements:**

Computer Box 2.

Part no.	Product name
L-019-0709	MOT1 with front panel

### MOT3 board with ejector



**Type of part:**  
PCB

**Part is replacing:**

L-029-0080

**Description**

MOT3 board for machines with Computer box 1.

**Machine type:**

TP11 , TP12 , TP18 , TP9-1 , TP9-2 , TP9-3 , TP9-4

**Requirements:**

Computer Box 1. The MOT3 is the third generation of the motor controller boards. It's for use with the MYDATA pick and place machines and the MYDATA tray exchanger (TEX). A existing MOT2 can be replaced by a MOT3 with the following restrictions:

1. When used as MOT-X in machine equipped with XWB2, the XWB2 board needs to be revision 8 or later.
2. When used as MOT-X in a machine equipped with 2um transducers (i.e. TP9-4, TP11 and MY-series), x-servo xd33 or later is required for HYDRA machines and xd32 or later for none HYDRA machines.
3. When used as MOT-M, m-servo m40g9 or later is required. Note! If the machine is to have a glue station, a GS-2 glue station must be used. The GS glue station only works with a MOT1 as MOT-M. The MOT3 can not be used in the old style Tray Elevator. Both servos mentioned above are incorporated in servo release 1.6.16.

Part no.	Product name
L-049-0008	MOT3 board with ejector

### MOT3 with front panel



**Type of part:**  
PCB

**Part is replacing:**

L-029-0304

**Machine type:**

MY12 , MY15 , MY19 , MY9 , TP11 , TP9-2 , TP9-4 , Tray Exchanger

**Requirements:**

Computer box 2. The MOT3 is the third generation of the motor controller boards. It's for use with the MYDATA pick and place machines and the MYDATA tray exchanger (TEX). A existing MOT2 can be replaced by a MOT3 with the following restrictions:

1. When used as MOT-X in machine equipped with XWB2, the XWB2 board needs to be revision 8 or later.
2. When used as

MOT-X in a machine equipped with 2um transducers (i.e. TP9-4, TP11 and MY-series), x-servo xd33 or later is required for HYDRA machines and xd32 or later for none HYDRA machines. 3. When used as MOT-M, m-servo m40g9 or later is required. Note! If the machine is to have a glue station, a GS-2 glue station must be used. The GS glue station only works with a MOT1 as MOT-M.

Part no.	Product name
L-049-0162	MOT3 with front panel

## Multi-port serial board



**Type of part:**  
PCB

### Description

8 channel serial board.

### Machine type:

TP9-1 , TP9-2 , TP9-3 , TP9-4 , TP11 , TP12 , TP18

### Requirements:

PC Vision or TPSys software

Part no.	Product name
K-019-0189	Multi-port serial board

## Network card SMC Lanet16C



**Type of part:**  
PCB

**Part is replacing:**  
K-019-0003

### Description

Network board for use when connecting a machine to a local network or sharing data between two or more machines.

### Machine type:

MY19 , TP11 , TP12 , TP18 , TP9-1 , TP9-2 , TP9-3 , TP9-4

### Requirements:

TPSys 1.6 or earlier.

Part no.	Product name
K-019-0003B	Network card SMC Lanet16C

## SCSI Board



**Type of part:**  
PCB

### Machine type:

MY9 , MY12 , MY15 , MY19

Part no.	Product name
K-049-0006	SCSI Board

## VGA Video board



**Type of part:**  
PCB

**Part is replacing:**  
K-019-0210

### Machine type:

MY15 , MY19 , TP11 , TP9-4

Part no.	Product name
K-019-0210B	VGA Video board

## Video Multi-plexer



**Type of part:**  
PCB

### Machine type:

TP9-1 , TP9-2

### Requirements:

PC vision.

Part no.	Product name
K-019-0187B	Video Multi-plexer

### VVG2 edition 2C with 4MB

**Type of part:**  
PCB

**Part is replacing:**  
L-019-0991

**Machine type:**  
TP9-1 , TP9-2 , TP9-3 , TP9-4 , TP11 , TP12 , TP18 , MY9 , MY12 , MY15 , MY19

Part no.	Product name
L-019-0827-2C	VVG2 edition 2C with 4MB

### Pico fuse



#### Description

**Requirements:**  
TPSys 1.4.7 or earlier, SYS 2.9.

Part no.	Product name
E-041-0240	Fuse ultra-fast 1.5 A (pico)
E-041-0232	Fuse ultra fast 1/16 A (pico)
E-041-0245	Fuse ultra fast 4 A (pico)

### AT-CPU PF2 with CP54 boxed

**Type of part:**  
Unit

**Machine type:**  
TP9-1 , TP9-2 , TP9-3 , TP9-4 , TP11 , TP12 , TP18

**Requirements:**  
Computer box 1. TPSys 2.4.3 or later

Part no.	Product name
L-019-1150	AT-CPU PF2 with CP54 boxed

### AT-CPU with CP4



**Type of part:**  
Unit

**Part is replacing:**  
L-019-0998B

**Machine type:**  
TP9-1 , TP9-2 , TP9-3 , TP9-4 , TP11 , TP12 , TP18

**Requirements:**  
Computer Box 1.

Part no.	Product name
L-019-1083	AT-CPU with CP4

### AT-CPU with CP54 for Linux



**Type of part:**  
Unit

**Part is replacing:**  
L-019-1028

**Description**  
For machines upgraded with CP54.

**Machine type:**  
TP11 , TP12 , TP18 , TP9-1 , TP9-2 , TP9-3 , TP9-4

**Requirements:**  
CP54. Computer Box 1.

Part no.	Product name
L-019-1084	AT-CPU with CP54 for Linux

**AT-CPU2 PF2 with CP5 boxed**

**Type of part:**  
Unit

**Machine type:**  
TP9-4 , TP11 , TP18 , MY9 , MY12 , MY15 , MY19

**Requirements:**  
TPSys 2.4.3 or later.

Part no.	Product name
L-019-1152	AT-CPU2 PF2 with CP5 boxed

**AT-CPU2 PF2 with CP54 boxed**

**Type of part:**  
Unit

**Machine type:**  
TP9-2 , TP9-4 , TP11

**Requirements:**  
Computer Box 2. TPSys 2.4.3 or later.

Part no.	Product name
L-019-1151	AT-CPU2 PF2 with CP54 boxed

**AT-CPU2 with CP5**

**Type of part:**  
Unit

**Part is replacing:**  
L-019-1086

**Machine type:**  
MY12 , MY15 , MY19 , MY9 , TP11 , TP9-2 , TP9-4

**Requirements:**  
Computer Box 2, CP5.

Part no.	Product name
L-019-1098	AT-CPU2 with CP5

**AT-CPU2 with CP54 for Linux**

**Type of part:**  
Unit

**Part is replacing:**  
L-019-1029

**Description**  
For machines upgraded with CP54.

**Machine type:**  
TP11 , TP9-2 , TP9-4

**Requirements:**  
CP54. Computer Box 2.

Part no.	Product name
L-019-1087	AT-CPU2 with CP54 for Linux

**BM4CB edition 2**

**Type of part:**  
Unit

**Part is replacing:**  
L-049-0268

**Machine type:**  
MY9 , MY12 , MY15 , MY19

Part no.	Product name
L-029-0533-2	BM4CB edition 2



**BOX 12V 5V**



Type of part:  
Unit

Machine type:  
MY12 , MY15 , MY19 , MY9

Requirements:  
UPS with 230V output.

Part no.	Product name
L-049-0241	BOX 12V 5V

Part no.	Product name
L-019-0001-4	Computer Box 1

**Computer Box 2**



Type of part:  
Unit

Machine type:  
MY9 , MY12 , MY15 , MY19

Part no.	Product name
L-049-0184	Computer Box 2

**Computer Box 1**



Type of part:  
Unit

Machine type:  
TP9-3 , TP9-4 , TP11 , TP12 , TP18

Requirements:  
TPSys

Part no.	Product name
L-029-0267-1	Computer Box 1

**Computer Box 2**



Type of part:  
Unit

Part is replacing:  
L-029-0301-1

Machine type:  
TP11 , TP9-2 , TP9-4

Part no.	Product name
L-029-0301B	Computer Box 2

**Computer Box 1**



Type of part:  
Unit

Machine type:  
TP9-1 , TP9-2

**Computer box 2 with BM4**

Type of part:  
Unit

Machine type:  
MY9 , MY12 , MY15 , MY19

Part no.	Product name
L-049-0254	Computer box 2 with BM4

**CRT Monitor**

**Type of part:**  
Unit

**Part is replacing:**  
K-049-0077A K-049-0078A

**Machine type:**

MY12 , MY15 , MY19 , MY9 , TP11 , TP12 , TP18 , TP9-1 , TP9-2 , TP9-3 , TP9-4

**Requirements:**

CP5, CP54 or PC server.

Part no.	Product name
----------	--------------

L-049-0117	CRT Monitor
------------	-------------

Part no.	Product name
----------	--------------

L-049-0141	MI-MOT3 unit with ejector
------------	---------------------------

**MI with front panel**

**Type of part:**  
Unit

**Machine type:**

MY12 , MY15 , MY19 , MY9 , TP11 , TP12 , TP18 , TP9-2 , TP9-4

**Requirements:**

Computer Box 2.

Part no.	Product name
----------	--------------

L-019-0710	MI with front panel
------------	---------------------

**JFKB joystick full keyboard**

**Type of part:**  
Unit

**Description**

Keyboard with Joystick.

**Machine type:**

TP9-1 , TP9-2

**Requirements:**

SYS 2.9

Part no.	Product name
----------	--------------

L-019-0055-1	JFKB joystick full keyboard
--------------	-----------------------------

**Monitor 12" monochrome**

**Type of part:**  
Unit

**Description**

B/W monitor for SYS2.9 machines or TP Sys machines.

**Machine type:**

TP9-1 , TP9-2 , TP9-3 , TP12 , TP18

Part no.	Product name
----------	--------------

K-019-0147	Monitor 12" monochrome
------------	------------------------

**MI-MOT3 unit with ejector****Type of part:**

Unit

**Machine type:**

TP11 , TP12 , TP18 , TP9-1 , TP9-2 , TP9-3 , TP9-4

**Monitor RGB****Type of part:**

Unit

**Part is replacing:**

K-019-0214

**Machine type:**

TP9-1 , TP9-2 , TP9-3 , TP9-4 , TP11 , TP12 , TP18

Part no.	Product name
K-019-0389	Monitor RGB

### P4-CP2 complete with front

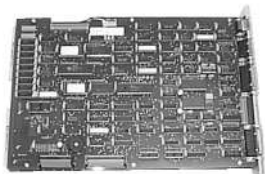

Type of part:  
Unit

Machine type:  
TP9-1 , TP9-2

Requirements:  
SYS 2.9

Part no.	Product name
L-019-0058	P4-CP2 complete with front

### Upgrade kit 2.5" HD

Type of part:  
Update kit

Machine type:  
TP9-1 , TP9-2 , TP9-3 , TP9-4 , TP11 , TP12 , TP18 , MY9 , MY12 ,  
MY15 , MY19

Part no.	Product name
L-019-1155	Upgrade kit 2.5" HD



**Bracket for Sunx sensor**

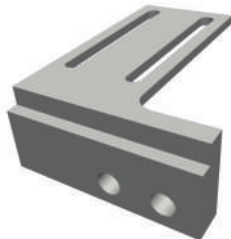

Part no.	Product name
D-025-0523	Bracket for Sunx sensor
D-025-0524	Long bracker for SUNX sensor

**Smema cable**



Part no.	Product name
L-019-0521	SMEMA-in, cable
L-019-0522	SMEMA-out, cable

**Belt T2.5/120 B=6**



**Type of part:**  
Belt

**Part is replacing:**  
K-014-0002

**Description**  
For Fi axis, 270, 450 & 420PT conveyors.

**Machine type:**  
TP9-1 , TP9-2 , Magazine

Part no.	Product name
K-012-0002	Belt T2.5/120 B=6

**Belt T2.5/145 B=6**



**Type of part:**  
Belt

**Description**  
For 500T, 270, 500T2 & 420PT Conveyors.

**Machine type:**  
MY12 , MY15 , MY19 , MY9 , TP11 , TP12 , TP18 , TP9-1 , TP9-2 , TP9-3 , TP9-4

Part no.	Product name
K-015-0032	Belt T2.5/145 B=6

**Belt T2.5/200 B=6**



**Type of part:**  
Belt

**Description**

**Machine type:**  
MY12 , MY15 , MY19 , MY9 , TP11 , TP12 , TP18 , TP9-1 , TP9-2 , TP9-3 , TP9-4

**Requirements:**  
500T & 500T2 conveyors.

Part no.	Product name
K-025-0014	Belt T2.5/200 B=6

**Belt T2.5/540 B=6**



**Type of part:**  
Belt

**Machine type:**  
MY12 , MY15 , MY19 , MY9 , TP11 , TP12 , TP18 , TP9-1 , TP9-2 , TP9-3 , TP9-4

**Requirements:**

500T & 500T2 conveyors.

Part no.	Product name
K-025-0016	Belt T2.5/540 B=6

**Belt T2.5/650 B=6**

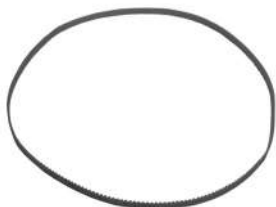

**Type of part:**  
Belt

**Description**

For 270, 450 & 420PT Conveyors.

**Machine type:**

MY12, MY15, MY19, MY9, TP11, TP12, TP18, TP9-1, TP9-2, TP9-3, TP9-4

Part no.	Product name
K-015-0037	Belt T2.5/650 B=6

**Belt T5/1100 B=6**

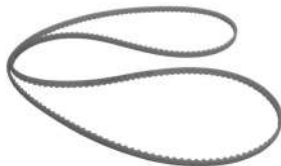

**Type of part:**  
Belt

**Description**

For 270, 450 & 420PT Conveyors.

**Machine type:**

MY12, MY15, MY19, MY9, TP11, TP12, TP18, TP9-1, TP9-2, TP9-3, TP9-4

Part no.	Product name
K-015-0038	Belt T5/1100 B=6

**Belt T5/920 B=6**

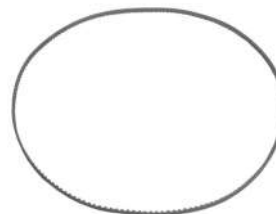

**Type of part:**  
Belt

**Description**

**Machine type:**

MY12, MY15, MY19, MY9, TP11, TP12, TP18, TP9-1, TP9-2, TP9-3, TP9-4

**Requirements:**

500T & 500T2 conveyors.

Part no.	Product name
K-025-0015	Belt T5/920 B=6

**Board transport belt**



**Type of part:**  
Belt

**Machine type:**

MY12, MY15, MY19, MY9, TP11, TP12, TP18, TP9-1, TP9-2, TP9-3, TP9-4

**Requirements:**

500T2 or 420PT Conveyor.

Part no.	Product name
U-025-0001-4	Board transport belt

**Board transport belt T2.5/1300 B=4**

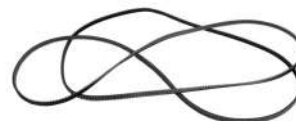

**Type of part:**  
Belt

**Description**

Board transport belt for 500T, 270 & 450 conveyors. 1.8mm thick with green surface.

**Machine type:**

TP9-1, TP9-2, TP9-3, TP9-4, TP11, TP12, TP18

Part no.	Product name
K-015-0011-R	Board transport belt T2.5/1300 B=4

### T5 transport belt

**Type of part:**  
Belt

**Description**  
2 pcs - belt 1670x10

**Machine type:**  
MY9 , MY12 , MY15 , MY19

**Requirements:**  
Board handling system T5

Part no.	Product name
L-045-0436	T5 transport belt

### T6 transport belt

**Type of part:**  
Belt

**Description**  
2 pcs - belt 2025x9.8

**Machine type:**  
MY9 , MY12 , MY15 , MY19

**Requirements:**  
Board handling system T6

Part no.	Product name
L-045-0430	T6 transport belt

### Conveyor safety adapter cable

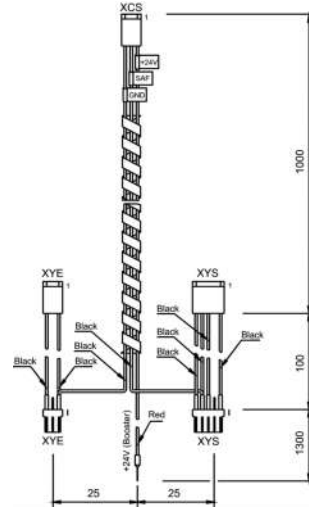

**Type of part:**  
Cable

**Machine type:**  
MY12 , MY15 , MY19 , MY9 , TP11 , TP12 , TP18 , TP9-1 , TP9-2 , TP9-3 , TP9-4

**Requirements:**  
270PT, 450PT, 420PT, 400PT, 500T or 500T2 Conveyor.

Part no.	Product name
L-019-0426	Conveyor safety adapter cable

### Conveyor safety cable (double)

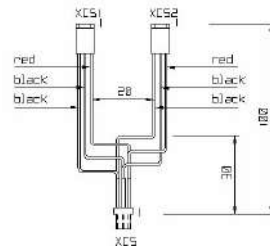

**Type of part:**  
Cable

**Machine type:**  
MY12 , MY15 , MY19 , MY9 , TP11 , TP12 , TP18 , TP9-1 , TP9-2 , TP9-3 , TP9-4

**Requirements:**  
500T & 500T2 Conveyor.

Part no.	Product name
L-019-0427	Conveyor safety cable (double)



### Conveyor safety sensor

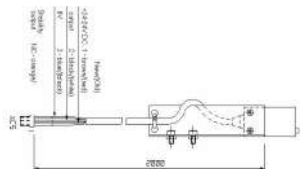

Type of part:  
Cable

**Description**  
GSR05RS/N or GR02S/N.

**Machine type:**  
TP11, TP12, TP18, TP9-1, TP9-2, TP9-3, TP9-4

**Requirements:**  
270, 450 or 500T Conveyor.

Part no.	Product name
L-019-0428B	Conveyor safety sensor

### SMEMA-adapter



Type of part:  
Cable

**Description**  
DIN5 C-male - CPC14P-female.

**Machine type:**  
MY12, MY15, MY19, MY9, TP11, TP9-4

Part no.	Product name
L-019-0778	SMEMA-adapter

### SMEMA-adapter



Type of part:  
Cable

**Description**  
CPC14P-male DIN5 C-female.

**Machine type:**  
MY12, MY15, MY19, MY9, TP11, TP9-4

Part no.	Product name
L-019-0777	SMEMA-adapter

### Smema CPC14P - CPC14P cable



Type of part:  
Cable

**Machine type:**  
MY12, MY15, MY19, MY9, TP11, TP12, TP18, TP9-1, TP9-2, TP9-3, TP9-4

Part no.	Product name
L-019-0865	Smema CPC14P - CPC14P cable

### XFL board position sensor

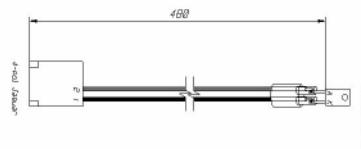

Type of part:  
Cable

**Machine type:**  
MY12, MY15, MY19, MY9, TP11, TP12, TP18, TP9-1, TP9-2, TP9-3, TP9-4

**Requirements:**  
270PT, 450PT, 420PT, 400PT, 500T or 500T2 Conveyor.

Part no.	Product name
L-019-0253	XFL board position sensor

### XGTS connection block cable

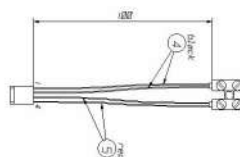

Type of part:  
Cable

**Machine type:**  
TP11, TP12, TP18, TP9-1, TP9-2, TP9-3, TP9-4

**Requirements:**  
270, 450, 500T, 500T2 or 420PT Conveyor.

Part no.	Product name
L-019-0505	XGTS connection block cable

### XMFC YWU3 conveyor cable

**Type of part:**  
Cable

**Machine type:**  
TP9-1 , TP9-2 , TP9-3 , TP9-4 , TP11 , TP12 , TP18 , MY9 , MY12 , MY15 , MY19

Part no.	Product name
L-019-0842B	XMFC YWU3 conveyor cable

### XMFE conveyor cable

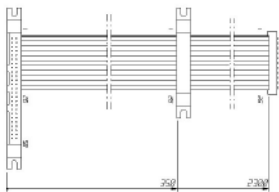

**Type of part:**  
Cable

**Machine type:**  
TP9-1 , TP9-2 , TP9-3 , TP9-4 , TP11 , TP12 , TP18

**Requirements:**  
270 or 450 Conveyor.

Part no.	Product name
L-019-0239B	XMFE conveyor cable

### XMFE2 Y Wagon cable



**Type of part:**  
Cable

**Machine type:**  
TP9-1 , TP9-2 , TP9-3 , TP9-4 , TP11 , TP12 , TP18

**Requirements:**  
500T or 500T2 Conveyor.

Part no.	Product name
L-029-0089	XMFE2 Y Wagon cable

### XYCM Y motor extension cable

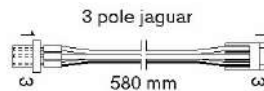

**Type of part:**  
Cable

**Machine type:**  
TP9-1 , TP9-2 , TP9-3 , TP9-4 , TP11 , TP12 , TP18

**Requirements:**  
450 Conveyor.

Part no.	Product name
L-019-0287	XYCM Y motor extension cable

### XYF Y Wagon flat cable

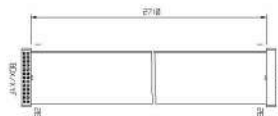

**Type of part:**  
Cable

**Machine type:**  
TP12 , TP18

Part no.	Product name
L-029-0055	XYF Y Wagon flat cable

### Y-conveyor flat cable

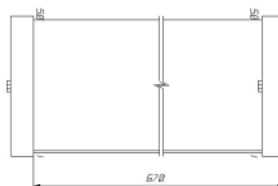

**Type of part:**  
Cable

**Machine type:**  
TP9-1 , TP9-2 , TP9-3 , TP9-4 , TP11 , TP12 , TP18

**Requirements:**  
270 or 450 Conveyor.

Part no.	Product name
L-019-0255	Y-conveyor flat cable

### YMFC conveyor cable

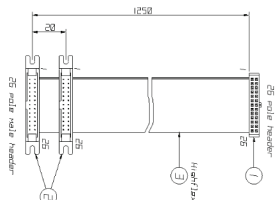

Type of part:  
Cable

#### Machine type:

TP9-1 , TP9-2 , TP9-3 , TP9-4 , TP11 , TP12 , TP18 , MY9 , MY12 , MY15 , MY19

#### Requirements:

500T2 Conveyor.

Part no.	Product name
L-019-0843	YMFC conveyor cable

### Belt pulley



Type of part:  
Cog wheel

#### Description

Belt pulley for 270 & 450 conveyors.

#### Machine type:

TP9-1 , TP9-2 , TP9-3 , TP9-4 , TP11 , TP12 , TP18

Part no.	Product name
D-015-0248-4	Belt pulley

### Belt pulley



Type of part:  
Cog wheel

#### Description

Belt pulley for 270, 450, 500T & 420PT conveyors.

#### Machine type:

TP9-1 , TP9-2 , TP9-3 , TP9-4 , TP11 , TP12 , TP18 , MY9 , MY12 , MY15 , MY19

Part no.	Product name
D-015-0239-3	Belt pulley

### Belt pulley



Type of part:  
Cog wheel

#### Description

Belt pulley for 270, 450, 500T & 420PT conveyors.

#### Machine type:

MY12 , MY15 , MY19 , MY9 , TP11 , TP12 , TP18 , TP9-1 , TP9-2 , TP9-3 , TP9-4

Part no.	Product name
D-015-0240-3	Belt pulley

### Board jam sensor with connector



Type of part:  
Electrical component

**Machine type:**  
MY9, MY12, MY15, MY19

Part no.	Product name
L-049-0508	Board jam sensor with connector

**Conveyor dummy din connector**

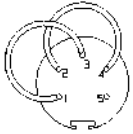

Solder a JUMPER between PIN 1 and 3 and between PIN 2 and 4

**Type of part:**  
Electrical component

**Machine type:**  
MY12, MY15, MY19, MY9, TP11, TP12, TP18, TP9-1, TP9-2, TP9-3, TP9-4

**Requirements:**  
270, 450, 500T, 500T2 & 420PT Conveyor.

Part no.	Product name
L-019-0403	Conveyor dummy din connector

**Conveyor safety sensor**

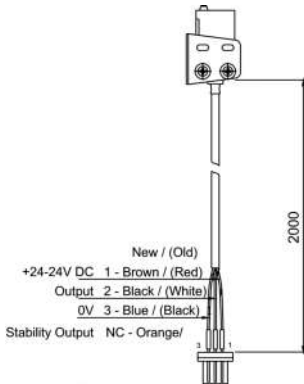

**Type of part:**  
Electrical component

**Description**  
SEEKA GSR05RS/N or GSR05RS/N.

**Machine type:**  
TP9-1, TP9-2, TP9-3, TP9-4, TP11, TP12, TP18

**Requirements:**  
270, 450 or 500T Conveyor.

Part no.	Product name
L-019-0440	Conveyor safety sensor

**Membrane push button**



**Type of part:**  
Electrical component

**Machine type:**  
TP9-1, TP9-2, TP9-3, TP9-4, TP11, TP12, TP18, MY9, MY12, MY15, MY19

**Requirements:**  
Conveyor

Part no.	Product name
E-011-0019	Membrane push button

**SMEMA CPC14P dummy connector**



**Type of part:**  
Electrical component

**Machine type:**  
MY12, MY15, MY19, MY9, TP11, TP9-4

Part no.	Product name
L-019-0866	SMEMA CPC14P dummy connector

**Stepper motor controller board**

**Type of part:**  
Electrical component

**Description**  
ISEL automation 313303.

**Machine type:**  
MY12, MY15, MY19, MY9, TP11, TP12, TP18, TP9-1, TP9-2, TP9-3, TP9-4

**Requirements:**

Loader or Unloader.

Part no.	Product name
K-017-0106	Stepper motor controller board

**SUNX EX14A reflex sensor**

**Type of part:**

Electrical component

**Machine type:**

MY12, MY15, MY19, MY9, TP11, TP12, TP18, TP9-1, TP9-2, TP9-3, TP9-4

Part no.	Product name
E-040-0159	SUNX EX14A reflex sensor

**Board sensor**

**Type of part:**

Kit

**Description**

Sensor Keyence FU-12

**Machine type:**

MY9, MY12, MY15, MY19

**Requirements:**

Board handling system T3-T6

Part no.	Product name
L-045-0434	Board sensor

**Control board**

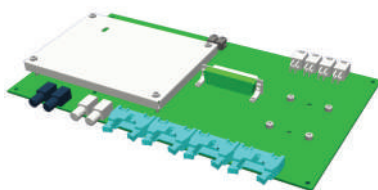

**Type of part:**  
Kit

**Description**

Control Board (CB) with CMOT

**Machine type:**

MY9, MY12, MY15, MY19

**Requirements:**

Board handling system T3-T6

Part no.	Product name
L-045-0437	Control board

**Guide bushing kit**

**Type of part:**

Kit

**Machine type:**

MY9, MY12, MY15, MY19

**Requirements:**

Conveyor T3, T4, T5 or T6

Part no.	Product name
L-045-0651	Guide bushing kit

**Safety switch front hood**

**Type of part:**

Kit

**Machine type:**

MY9, MY12, MY15, MY19

**Requirements:**

Board handling system T5/T6

Part no.	Product name
L-045-0423	Safety switch front hood

**Safety switch rear hood**

**Type of part:**

Kit

**Machine type:**

MY9, MY12, MY15, MY19

**Requirements:**

Board handling system T5/T6

Part no.	Product name
L-045-0420	Safety switch rear hood

### Slide part support kit

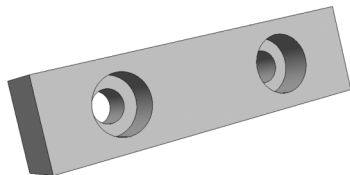

**Type of part:**  
Kit

**Description**

Kit with 4 curve slide parts and screws for the support table.

**Machine type:**

MY9 , MY12 , MY15 , MY19

**Requirements:**

Board handling system T5/T6

Part no.	Product name
L-045-0441	Slide part support kit

### Spare screw kit small

**Type of part:**

Kit

**Description**

- 2 pcs - screw MF6S 4x8
- 2 pcs - guide washer
- 2 pcs - pin CPK 5x30
- 2 pcs - guide pin
- 2 pcs - spherical seating washer M
- 2 pcs - spherical seating washer F

**Machine type:**

MY9 , MY12 , MY15 , MY19

**Requirements:**

Board handling system T5/T6

Part no.	Product name
L-045-0415	Spare screw kit small

### Spare screw kit T3/T4

**Type of part:**

Kit

**Machine type:**

MY9 , MY12 , MY15 , MY19

Part no.	Product name
L-045-0550	Spare screw kit T3/T4

### Spare screw kit T5/T6

**Type of part:**

Kit

**Description**

Parts for hood:

- 2 pcs - washer BRB 4.3x9x0.8
- 2 pcs - nut M6M M4
- 2 pcs - screw MC6S 4x10
- 2 pcs - screw MC6S 4x12
- 2 pcs - screw MC6S 4x30
- 4 pcs - screw MC6S 4x6
- 10 pcs - screw MC6S 4x8
- 2 pcs - screw MC6S 6x12
- 2 pcs - screw MC6S 6x16
- 2 pcs - screw MC6S 6x8
- 2 pcs - screw MC6S 8x20
- 2 pcs - screw MF6S 5x10
- 2 pcs - screw MF6S 6x12
- 4 pcs - screw MFX-Z 3x6
- 2 pcs - screw MRX-Z 3x6
- 2 pcs - screw MRX-Z 4x8
- 10 pcs - washer SPBR 4.1x8.2x0.8
- 2 pcs - washer SPBR 6x12.2x1.2
- 2 pcs - washer SPBR 8.2x16.2x1.4
- 4 pcs - screw MF6S 4x8

Parts for T5/T6:

- 2 pcs - guide washer
- 2 pcs - screw MC6S 4x16
- 2 pcs - screw MFX-Z 3x6
- 10 pcs - screw MC6S 4x10
- 2 pcs - screw MC6S 3x10
- 6 pcs - screw MC6S 4x12
- 2 pcs - screw MF6S 3x10
- 2 pcs - screw MC6S 6x35
- 2 pcs - pin CPK 5x30

Parts for YM:

- 2 pcs - guide pin
- 2 pcs - screw K6S 6x25
- 2 pcs - washer BRB 6.4x12x1.6
- 2 pcs - washer BRB 8.4x16x1.5
- 2 pcs - nut M6M M4
- 2 pcs - nut M6M M6
- 4 pcs - screw MC6S 4x16
- 2 pcs - screw MC6S 6x30
- 2 pcs - screw MC6S 6x40
- 2 pcs - screw MC6S 8x30
- 4 pcs - washer SPBR 4.1x8.2x0.8
- 2 pcs - screw MF6S 4x8
- 4 pcs - screw MC6S 6x25
- 2 pcs - screw MC6SF 6x16
- 2 pcs - washer BRB 4.3x12x1
- 2 pcs - spherical seating washer M
- 2 pcs - spherical seating washer F

2 pcs - washer BRB 3.2\*8\*1  
2 pcs - screw MC6S 3x30

**Machine type:**  
MY9 , MY12 , MY15 , MY19

**Requirements:**  
Board handling system T5/T6

Part no.	Product name
L-045-0414	Spare screw kit T5/T6

### Spring package 500T2 special left



**Type of part:**  
Kit

**Description**  
One for each 500T2 conveyor.

**Machine type:**  
MY12 , MY15 , MY19 , MY9 , TP11 , TP12 , TP18 , TP9-1 , TP9-2 , TP9-3 , TP9-4

Part no.	Product name
L-025-0192	Spring package 500T2 special left

### Spring package 500T2 special left



**Type of part:**  
Kit

**Description**  
Two for each 500T2 conveyor.

**Machine type:**  
MY12 , MY15 , MY19 , MY9 , TP11 , TP12 , TP18 , TP9-1 , TP9-2 , TP9-3 , TP9-4

Part no.	Product name
L-025-0194	Spring package 500T2 special left

### Spring package 500T2 special right



**Type of part:**  
Kit

**Description**  
One for each 500T2 conveyor.

**Machine type:**  
MY12 , MY15 , MY19 , MY9 , TP11 , TP12 , TP18 , TP9-1 , TP9-2 , TP9-3 , TP9-4

Part no.	Product name
L-025-0195	Spring package 500T2 special right

### Spring package 500T2 special right



**Type of part:**  
Kit

**Description**  
Two for each 500T2 conveyor.

**Machine type:**  
MY12 , MY15 , MY19 , MY9 , TP11 , TP12 , TP18 , TP9-1 , TP9-2 , TP9-3 , TP9-4

Part no.	Product name
L-025-0193	Spring package 500T2 special right

### T3 cylindrical pin guide kit

**Type of part:**  
Kit

**Machine type:**  
MY9 , MY12 , MY15 , MY19

**Requirements:**  
Conveyor T3 or T4

Part no.	Product name
L-045-0650	T3 cylindrical pin guide kit

### T3 drive belt kit

**Type of part:**  
Kit

**Machine type:**  
MY9 , MY12 , MY15 , MY19

Part no.	Product name
L-045-0556	T3 drive belt kit

### T3 Gable top kit

**Type of part:**  
Kit

**Machine type:**  
MY9, MY12, MY15, MY19

Part no.	Product name
L-045-0552	T3 Gable top kit

### T3 lift edge kit

**Type of part:**  
Kit

**Machine type:**  
MY9, MY12, MY15, MY19

Part no.	Product name
L-045-0558	T3 lift edge kit

### T4 drive belt kit

**Type of part:**  
Kit

**Machine type:**  
MY9, MY12, MY15, MY19

Part no.	Product name
L-045-0555	T4 drive belt kit

### T4 Gable top

**Type of part:**  
Kit

**Machine type:**  
MY9, MY12, MY15, MY19

Part no.	Product name
L-045-0551	T4 Gable top

### T4 lift edge kit

**Type of part:**  
Kit

**Machine type:**  
MY9, MY12, MY15, MY19

Part no.	Product name
L-045-0557	T4 lift edge kit

### T4 transport belt kit

**Type of part:**  
Kit

**Machine type:**  
MY9, MY12, MY15, MY19

Part no.	Product name
L-045-0553	T4 transport belt kit

### T5 drive belt kit

**Type of part:**  
Kit

**Description**  
3 pcs - belt 210x10  
1 pce - belt 245x10  
1 pce - belt 1315x10

**Machine type:**  
MY9, MY12, MY15, MY19

**Requirements:**  
Board handling system T5

Part no.	Product name
L-045-0431	T5 drive belt kit

### T5 gable top kit

**Type of part:**  
Kit

**Machine type:**  
MY9, MY12, MY15, MY19

**Requirements:**  
Board handling system T5



Part no.	Product name
L-045-0426	T5 gable top kit

### T5 Lift edge kit

**Type of part:**  
Kit

**Description**  
Lift edge for fixed and moving gable with screws and washers

**Machine type:**  
MY9 , MY12 , MY15 , MY19

**Requirements:**  
Board handling system T5

Part no.	Product name
L-045-0439	T5 Lift edge kit

### T6 drive belt kit

**Type of part:**  
Kit

**Description**  
3 pcs - belt 210x10  
1 pce - belt 245x10  
1 pce - belt 1675x10

**Machine type:**  
MY9 , MY12 , MY15 , MY19

**Requirements:**  
Board handling system T6

Part no.	Product name
L-045-0429	T6 drive belt kit

### T6 gable top kit

**Type of part:**  
Kit

**Machine type:**  
MY9 , MY12 , MY15 , MY19

**Requirements:**  
Board handling system T6

Part no.	Product name
L-045-0440	T6 gable top kit

### T6 Lift edge kit

**Type of part:**  
Kit

**Description**  
Lift edge for fixed and moving gable with screws and washers

**Machine type:**  
MY9 , MY12 , MY15 , MY19

**Requirements:**  
Board handling system T6

Part no.	Product name
L-045-0433	T6 Lift edge kit

### Torsion spring kit

**Type of part:**  
Kit

**Machine type:**  
MY9 , MY12 , MY15 , MY19

**Requirements:**  
Conveyor T3 or T4

Part no.	Product name
L-045-0649	Torsion spring kit

### YM control board

**Type of part:**  
Kit

**Machine type:**  
MY9 , MY12 , MY15 , MY19

**Requirements:**  
Board handling system T3-T6

Part no.	Product name
L-045-0425	YM control board

### YM fan kit

**Type of part:**  
Kit

**Machine type:**  
MY9 , MY12 , MY15 , MY19

**Requirements:**  
Board handling system T3-T6

Part no.	Product name
L-045-0413	YM fan kit

### Board lock arm Conveyor



**Type of part:**  
Mechanical component

**Machine type:**  
MY12 , MY15 , MY19 , MY9 , TP11 , TP12 , TP18 , TP9-1 , TP9-2 , TP9-3 , TP9-4

**Requirements:**  
Conveyor 420PT or 400PT.

Part no.	Product name
D-025-0211B-3	Board lock arm Conveyor

### Board lock, left



**Type of part:**  
Mechanical component

**Description**  
For 500T & older generation of 500T2 Conveyor.

**Machine type:**  
MY12 , MY15 , MY19 , MY9 , TP11 , TP12 , TP18 , TP9-1 , TP9-2 , TP9-3 , TP9-4

Part no.	Product name
L-025-0010	Board lock, left

### Board lock, right



**Type of part:**  
Mechanical component

**Description**  
For 500T & older generation of 500T2 Conveyor.

**Machine type:**  
MY12 , MY15 , MY19 , MY9 , TP11 , TP12 , TP18 , TP9-1 , TP9-2 , TP9-3 , TP9-4

Part no.	Product name
L-025-0011	Board lock, right

### Bracket



**Type of part:**  
Mechanical component

**Description**  
Bracket for reducing vibration on 500T2 conveyor hood.

**Machine type:**  
MY9 , MY12 , MY15 , MY19

Part no.	Product name
D-015-1851	Bracket

### Card edge holder



**Type of part:**  
Mechanical component

**Description**  
For older generation of Conveyor 500T2.

**Machine type:**  
MY12 , MY15 , MY19 , MY9 , TP11 , TP12 , TP18 , TP9-1 , TP9-2 , TP9-3 , TP9-4

**Requirements:**  
Conveyor 500T and 500T2.

Part no.	Product name
D-025-0062-2	Card edge holder

### Card edge holder



**Type of part:**  
Mechanical component

**Machine type:**

TP9-1 , TP9-2 , TP9-3 , TP9-4 , TP11 , TP12 , TP18 , MY9 , MY12 , MY15 , MY19

**Requirements:**

Conveyor 420PT

Part no.	Product name
D-025-0195B-2	Card edge holder

### Card edge holder, conveyor



**Type of part:**  
Mechanical component

**Description**

For holding the PCB onto the transport belt on 270 or 450 conveyor.

**Machine type:**

TP9-1 , TP9-2 , TP9-3 , TP9-4 , TP11 , TP12 , TP18

**Requirements:**

270 or 450 conveyor.

Part no.	Product name
D-015-0256-2	Card edge holder, conveyor

### Conveyor bracket model 1



**Type of part:**  
Mechanical component

**Description**

For 500T Conveyor.

**Machine type:**

TP9-1 , TP9-2 , TP9-3 , TP9-4 , TP11 , TP12 , TP18

Part no.	Product name
L-025-0070	Conveyor bracket model 1

### Conveyor bracket model 2



**Type of part:**  
Mechanical component

**Description**

For 500T & 500T2 Conveyor.

**Machine type:**

TP9-1 , TP9-2 , TP9-3 , TP9-4 , TP11 , TP12 , TP18

Part no.	Product name
L-025-0075	Conveyor bracket model 2

### Conveyor bracket TP12/18



**Type of part:**  
Mechanical component

**Machine type:**

TP12 , TP18

Part no.	Product name
L-025-0071	Conveyor bracket TP12/18

### Expander wheel, conveyor



**Type of part:**  
Mechanical component

**Machine type:**

TP9-1 , TP9-2 , TP9-3 , TP9-4 , TP11 , TP12 , TP18

**Requirements:**

270 or 450 conveyor.

Part no.	Product name
L-015-0070	Expander wheel, conveyor

### Pin guide

**Type of part:**  
Mechanical component

**Machine type:**  
MY9, MY12, MY15, MY19

**Requirements:**  
Conveyor T3, T4, T5 or T6

Part no.	Product name
D-045-0064	Pin guide

### Plexiglass cover - 468 front



**Type of part:**  
Mechanical component

**Description**  
Plexiglass front cover on 468 manual load Y Wagon or 500T conveyor.

**Machine type:**  
MY12, MY15, MY19, MY9, TP11, TP9-4

Part no.	Product name
D-015-0886-2	Plexiglass cover - 468 front

### Retainer board spring



**Type of part:**  
Mechanical component

**Description**  
For newer generation Conveyor 500T2.

**Machine type:**  
MY12, MY15, MY19, MY9, TP11, TP12, TP18, TP9-1, TP9-2, TP9-3, TP9-4

**Requirements:**  
Conveyor 500T2.

Part no.	Product name
D-025-0488B	Retainer board spring

### Sensor holder model 2



**Type of part:**  
Mechanical component

**Machine type:**  
MY12, MY15, MY19, MY9, TP11, TP12, TP18, TP9-1, TP9-2, TP9-3, TP9-4

**Requirements:**  
420PT or 500T2 Conveyor.

Part no.	Product name
L-019-0640	Sensor holder model 2

### Spring holder for conveyor



**Type of part:**  
Mechanical component

**Machine type:**  
TP9-1, TP9-2, TP9-3, TP9-4, TP11, TP12, TP18

**Requirements:**  
270 or 450 conveyor.

Part no.	Product name
L-015-0069	Spring holder for conveyor

### Square axle

**Type of part:**  
Mechanical component

**Machine type:**  
MY9, MY12, MY15, MY19

**Requirements:**  
Conveyor T3 or T4.

Part no.	Product name
D-045-0628	Square axle

### Support plate, conveyor

**Type of part:**  
Mechanical component

**Machine type:**  
TP9-1 , TP9-2 , TP9-3 , TP9-4 , TP11 , TP12 , TP18

**Requirements:**  
270 conveyor.

Part no.	Product name
L-015-0064	Support plate, conveyor

### Valve Rocker arm



**Type of part:**  
Mechanical component

**Machine type:**  
MY12 , MY15 , MY19 , MY9 , TP11 , TP12 , TP18 , TP9-1 , TP9-2 , TP9-3 , TP9-4

**Requirements:**  
420PT or 500T2 conveyor

Part no.	Product name
D-025-0216-4	Valve Rocker arm

### Nylon cord



**Type of part:**  
Miscellaneous

**Description**  
Sold per meter.

**Machine type:**  
MY12 , MY15 , MY19 , MY9 , TP11 , TP12 , TP18 , TP9-1 , TP9-2 , TP9-3 , TP9-4

**Requirements:**  
270, 450, 500T, 500T2 or 420PT Conveyor. 2.2m for YWU2/4. 1.0m for YWU1/3.

Part no.	Product name
K-015-0039	Nylon cord

### Scale cleaning wipes

**Type of part:**  
Miscellaneous

**Machine type:**  
MY9 , MY12 , MY15 , MY19

**Requirements:**  
Board handling system T3-T6

Part no.	Product name
K-035-0067	Scale cleaning wipes

### Sensor lens FU-12

**Type of part:**  
Miscellaneous

**Description**  
Sensor lens for board jam sensor.

**Machine type:**  
TP9-1 , TP9-2 , TP9-3 , TP9-4 , TP11 , TP12 , TP18 , MY9 , MY12 , MY15 , MY19

**Ordering info:**  
Delivered in pairs (2 pcs)

Part no.	Product name
K-045-0039	Sensor lens FU-12

**XYWH Y-width end position switch**



**Type of part:**  
Miscellaneous

**Machine type:**

TP9-1 , TP9-2 , TP9-3 , TP9-4 , TP11 , TP12 , TP18 , MY9 , MY12 , MY15 , MY19

**Requirements:**

Conveyor 500T2, 420PT or 400PT

Part no.	Product name
L-019-0251	XYWH Y-width end position switch

**Conveyor motor**



**Type of part:**  
Motor

**Part is replacing:**  
L-019-0008

**Description**

For width adjustment on conveyor.

**Machine type:**

MY12 , MY15 , MY19 , MY9 , TP11 , TP12 , TP18 , TP9-1 , TP9-2 , TP9-3 , TP9-4 , Tray Elevator

**Requirements:**

Conveyor 420PT or 500T2.

Part no.	Product name
L-029-0537	Conveyor motor

**24V DC motor + gear**



**Type of part:**  
Motor

**Part is replacing:**  
L-019-0106

**Description**

For board clamp and board transport on conveyor.

**Machine type:**

MY12 , MY15 , MY19 , MY9 , TP11 , TP12 , TP18 , TP9-1 , TP9-2 , TP9-3 , TP9-4

**Requirements:**

270, 450, 500T, 500T2 or 420PT Conveyor.

Part no.	Product name
L-019-0106B	24V DC motor + gear

**Motor board-transport conveyor**



**Type of part:**  
Motor

**Machine type:**

TP9-1 , TP9-2 , TP9-3 , TP9-4 , TP11 , TP12 , TP18

**Requirements:**

270 or 450 conveyor.

Part no.	Product name
L-015-0063	Motor board-transport conveyor

**Motor, width adjustment**



**Type of part:**  
Motor

**Machine type:**

TP9-1 , TP9-2 , TP9-3 , TP9-4 , TP11 , TP12 , TP18

**Requirements:**

270 or 450 conveyor.

Part no.	Product name
L-015-0061	Motor, width adjustment

### T3/T4 lift motor 1

**Type of part:**  
Motor

**Machine type:**  
MY9 , MY12 , MY15 , MY19

Part no.	Product name
L-045-0560	T3/T4 lift motor 1

### T3/T4 lift motor 2

**Type of part:**  
Motor

**Machine type:**  
MY9 , MY12 , MY15 , MY19

Part no.	Product name
L-045-0561	T3/T4 lift motor 2

### T3/T4 transport motor

**Type of part:**  
Motor

**Machine type:**  
MY9 , MY12 , MY15 , MY19

Part no.	Product name
L-045-0562	T3/T4 transport motor

### T3/T4 width motor

**Type of part:**  
Motor

**Machine type:**  
MY9 , MY12 , MY15 , MY19

Part no.	Product name
L-045-0563	T3/T4 width motor

### T5/T6 motor



**Type of part:**  
Motor

**Description**  
Maxon motor RE36 42v complete with cables

**Machine type:**  
MY9 , MY12 , MY15 , MY19

**Requirements:**  
Board handling system T5/T6

Part no.	Product name
L-045-0435	T5/T6 motor

### SLS



**Type of part:**  
PCB

**Machine type:**  
TP9-1 , TP9-2 , TP9-3 , TP9-4 , TP11 , TP12 , TP18

**Requirements:**  
270, 450 or 500T Conveyor.

Part no.	Product name
L-019-0226-1	SLS

### SLS2 ed 1



**Type of part:**  
PCB

**Description**  
Support plane dual opto fork set.

**Machine type:**  
MY12 , MY15 , MY19 , MY9 , TP11 , TP12 , TP18 , TP9-1 , TP9-2 , TP9-3 , TP9-4

**Requirements:**  
Conveyor 420PT or 500T2.

Part no.	Product name
L-019-0862-1	SLS2 ed 1

## YC edition 6

**Type of part:**  
PCB

**Part is replacing:**  
L-019-0225-5B

**Description**  
New functionality added:  
Compatibility with dual Sunx conveyor sensor.

**Machine type:**  
TP9-1 , TP9-2 , TP9-3 , TP9-4 , TP11 , TP12 , TP18 , MY9 , MY12 , MY15 , MY19

**Requirements:**  
270, 450, 500T, 500T2, 420PT or 400PT Conveyor.

Part no.	Product name
L-019-0225-6	YC edition 6

## Belt tension wheel

**Type of part:**  
Unit

**Machine type:**  
MY9 , MY12 , MY15 , MY19

**Requirements:**  
Conveyor T3 or T4

Part no.	Product name
L-045-0511	Belt tension wheel

## Conveyor safety sensor



**Type of part:**  
Unit

**Machine type:**  
MY12 , MY15 , MY19 , MY9 , TP11 , TP9-4

**Requirements:**  
Y Wagon Unit - YWU3, YWU4 or YWU5.

Part no.	Product name
L-019-0845	Conveyor safety sensor

## Lift table T3 sheetmetal

**Type of part:**  
Unit

**Machine type:**  
MY9 , MY12 , MY15 , MY19

Part no.	Product name
L-045-0509	Lift table T3 sheetmetal

## Lift table T4

**Type of part:**  
Unit

**Machine type:**  
MY9 , MY12 , MY15 , MY19

Part no.	Product name
L-045-0501	Lift table T4

## Reel spring for conveyor



**Type of part:**  
Unit

**Machine type:**  
MY12 , MY15 , MY19 , MY9 , TP11 , TP12 , TP18 , TP9-1 , TP9-2 , TP9-3 , TP9-4

**Requirements:**  
270, 450, 500T, 500T2 or 420PT Conveyor.

Part no.	Product name
L-015-0222B	Reel spring for conveyor



## T3/T4 hood safety switch

**Type of part:**

Unit

**Machine type:**

MY9 , MY12 , MY15 , MY19

Part no.	Product name
L-045-0564	T3/T4 hood safety switch

## Upgrade kit BJS

**Type of part:**

Update kit

**Description**

Board jam sensor upgrade kit for 500T2 with YWU5

**Machine type:**

TP9-4 , TP11 , MY9 , MY12 , MY15 , MY19

**Requirements:**

500T2 with YWU5

Part no.	Product name
L-015-0451	Upgrade kit BJS

**MY9/MY12/MY15/MY19 Maintenance guide**

Part no.	Product name
P-040-0055-EN	Maintenance guide - English
P-040-0055-DA	Maintenance guide - Danish
P-040-0055-NL	Maintenance guide - Dutch
P-040-0055-FI	Maintenance guide - Finnish
P-040-0055-FR	Maintenance guide - French
P-040-0055-DE	Maintenance guide - German
P-040-0055-IT	Maintenance guide - Italian
P-040-0055-JA	Maintenance guide - Japanese
P-040-0055-NO	Maintenance guide - Norwegian
P-040-0055-PT	Maintenance guide - Portuguese
P-040-0055-ES	Maintenance guide - Spanish
P-040-0055-SV	Maintenance guide - Swedish

**TPSys 2.4 Operator's manual****Description****Requirements:**

TPSys 2.4

Part no.	Product name
P-020-0023-EN	TPSys 2.4 Operator's manual - English
P-020-0023-FR	TPSys 2.4 Operator's manual - French
P-020-0023-DE	TPSys 2.4 Operator's manual - German
P-020-0023-JA	TPSys 2.4 Operator's Manual - Japanese
P-020-0023-FI	TPSys 2.4 Operator's manual - Finnish
P-020-0023-IT	TPSys 2.4 Operator's manual - Italian
P-020-0023-NL	TPSys 2.4 Operator's manual - Dutch
P-020-0023-PT	TPSys 2.4 Operator's manual - Portuguese

**TPSys 2.4 Programming manual****Description**

English version

**Requirements:**

TPSys 2.4

Part no.	Product name
P-020-0024-EN	TPSys 2.4 Programming manual - English
P-020-0024-FR	TPSys 2.4 Programming manual - French
P-020-0024-DE	TPSys 2.4 Programming manual - German
P-020-0024-JA	TPSys 2.4 Programming manual - Japanese
P-020-0024-FI	TPSys 2.4 Programming manual - Finnish
P-020-0024-IT	TPSys 2.4 Programming manual - Italian

**TPSys 2.5 Operator's manual****Requirements:**

TPSys 2.5

Part no.	Product name
P-020-0025-EN	TPSys 2.5 Operator's manual - English
P-020-0025-DE	TPSys 2.5 Operator's manual - German
P-020-0025-ES	TPSys 2.5 Operator's manual - Spanish
P-020-0025-FI	TPSys 2.5 Operator's manual - Finnish
P-020-0025-FR	TPSys 2.5 Operator's manual - French
P-020-0025-IT	TPSys 2.5 Operator's manual - Italian

**Machine manual, MY-series****Type of part:**

Miscellaneous

**Part is replacing:**

L-040-0233

**Machine type:**

MY9 , MY12 , MY15 , MY19

**Requirements:**

TPSys 2.4.3

Part no.	Product name
L-040-0556	Machine manual, MY-series

**MYPlan 3.0 User's Manual****Type of part:**

Miscellaneous

**Machine type:**

TP9-1 , TP9-2 , TP9-3 , TP9-4 , TP11 , TP12 , TP18 , MY9 , MY12 , MY15 , MY19

Part no.	Product name
P-010-0152-EN	MYPlan 3.0 User's Manual

**Safety Manual, MY Series & TP Series,****Type of part:**

Miscellaneous

**Description**

Multilingual - Danish, Dutch, English, Finnish, French, German, Italian, Norwegian, Portuguese, Spanish &amp; Swedish

**Machine type:**

MY12 , MY15 , MY19 , MY9 , TP11 , TP12 , TP18 , TP9-1 , TP9-2 , TP9-3 , TP9-4

Part no.	Product name
P-020-0016-MB	Safety Manual, MY Series & TP Series,

### TPSys 2.3 Operator's manual

**Type of part:**  
Miscellaneous

**Machine type:**  
MY12 , MY15 , MY19 , MY9 , TP11 , TP9-4

Part no.	Product name
P-020-0014-EN	TPSys 2.3 Operator's manual

### TPSys 2.3 Programming manual

**Type of part:**  
Miscellaneous

**Machine type:**  
MY12 , MY15 , MY19 , MY9 , TP11 , TP12 , TP18 , TP9-1 , TP9-2 , TP9-3 , TP9-4

Part no.	Product name
P-020-0015-EN	TPSys 2.3 Programming manual

### TPSys 2.3 Software manual

**Type of part:**  
Miscellaneous

**Machine type:**  
MY12 , MY15 , MY19 , MY9 , TP11 , TP12 , TP18 , TP9-1 , TP9-2 , TP9-3 , TP9-4

Part no.	Product name
P-010-0779-EN	TPSys 2.3 Software manual

### TPSys 2.4 Software manual

**Type of part:**  
Miscellaneous

**Description**  
English

**Machine type:**  
TP9-1 , TP9-2 , TP9-3 , TP9-4 , TP11 , TP12 , TP18 , MY9 , MY12 , MY15 , MY19

**Requirements:**  
TPSys 2.4

Part no.	Product name
P-010-0814-EN	TPSys 2.4 Software manual

### TPSys 2.5 machine manual

**Type of part:**  
Miscellaneous

**Description**  
English version

**Machine type:**  
MY9 , MY12 , MY15 , MY19

**Requirements:**  
TPSys 2.5

Part no.	Product name
P-020-0027-EN	TPSys 2.5 machine manual

### TPSys 2.5 Programming manual

**Type of part:**  
Miscellaneous

**Machine type:**  
MY9 , MY12 , MY15 , MY19

**Requirements:**  
TPSys 2.5

Part no.	Product name
P-020-0026-EN	TPSys 2.5 Programming manual

### TPSys 2.5 Software manual

**Type of part:**  
Miscellaneous

**Description**  
English version

**Machine type:**  
MY9 , MY12 , MY15 , MY19

**Requirements:**  
TPSys 2.5

Part no.	Product name
P-020-0028-EN	TPSys 2.5 Software manual



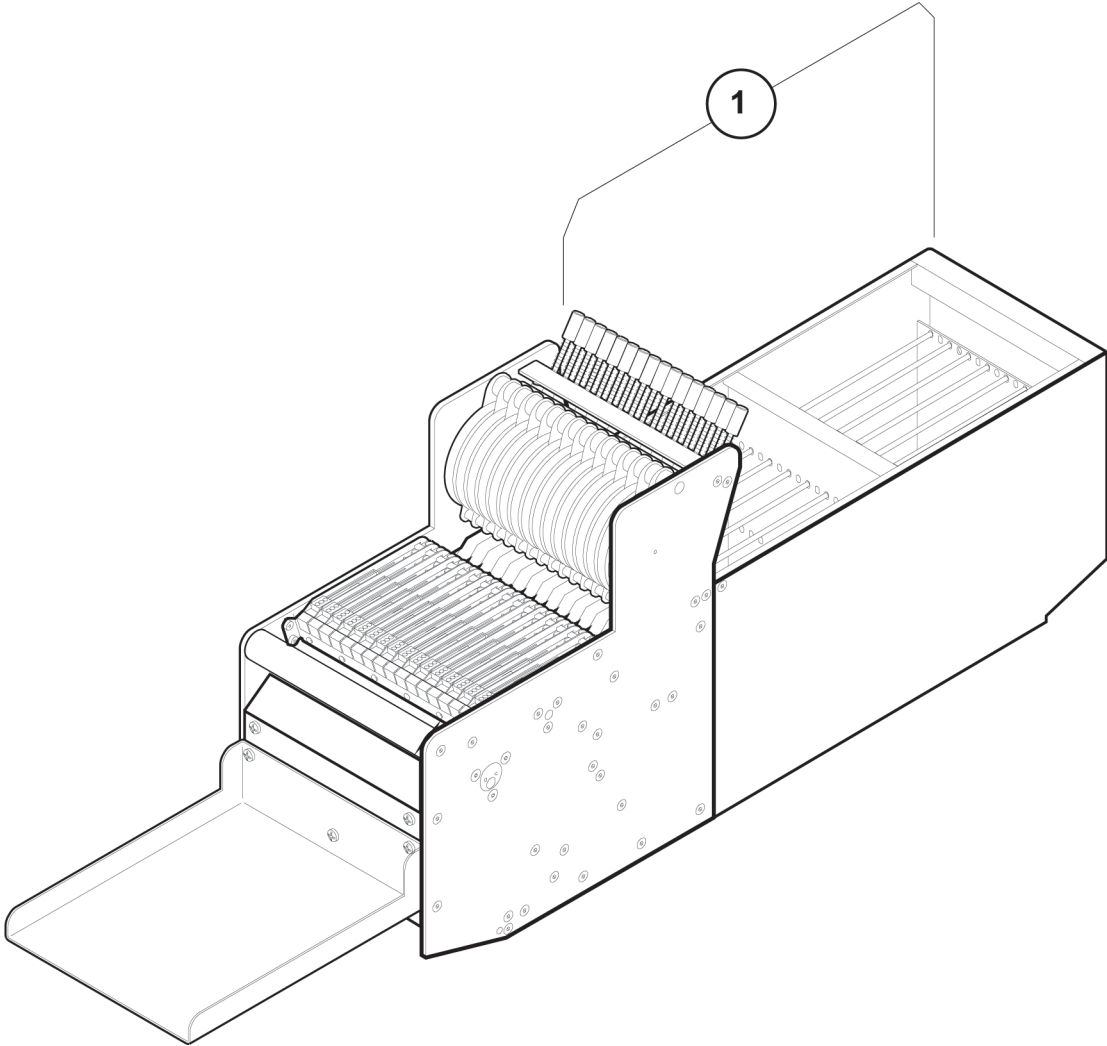

**Container for tape reels TM1216C**



**Position:** 1

**Type of part:**  
Unit

**Machine type:**  
Magazine

Part no.	Product name
L-014-0177	Container for tape reels TM1216C

**Container for tape reels TM12C**



**Position:** 1

**Type of part:**  
Mechanical component

**Machine type:**  
Magazine

Part no.	Product name
L-014-0175	Container for tape reels TM12C

**Container for tape reels TM16C**



**Position:** 1

**Type of part:**  
Mechanical component

**Machine type:**  
Magazine

Part no.	Product name
L-014-0176	Container for tape reels TM16C

**Container for tape reels TM24D**



**Position:** 1

**Type of part:**  
Mechanical component

**Machine type:**  
Magazine

Part no.	Product name
L-014-0178	Container for tape reels TM24D

**Container for tape reels TM32D**



**Position:** 1

**Type of part:**  
Unit

**Machine type:**  
Magazine

Part no.	Product name
L-014-0289	Container for tape reels TM32D

**Container for tape reels TM44D**



**Position:** 1

**Type of part:**  
Mechanical component

**Machine type:**  
Magazine

Part no.	Product name
L-014-0492	Container for tape reels TM44D

### Container for tape reels TM5632D



**Position:** 1  
**Type of part:**  
Unit

**Machine type:**  
Magazine

Part no.	Product name
L-014-0505	Container for tape reels TM5632D

### Container for tape reels TM8C



**Position:** 1  
**Type of part:**  
Unit

**Machine type:**  
Magazine

Part no.	Product name
L-014-0112	Container for tape reels TM8C

### Container for tape reels TM8FC

**Position:** 1

**Type of part:**  
Unit

**Machine type:**  
Magazine

Part no.	Product name
L-014-0449	Container for tape reels TM8FC

### Container for tape reels TMD Flex

**Position:** 1

**Type of part:**  
Unit

**Part is replacing:**  
L-014-0443

**Machine type:**  
Magazine

Part no.	Product name
L-014-0443D	Container for tape reels TMD Flex





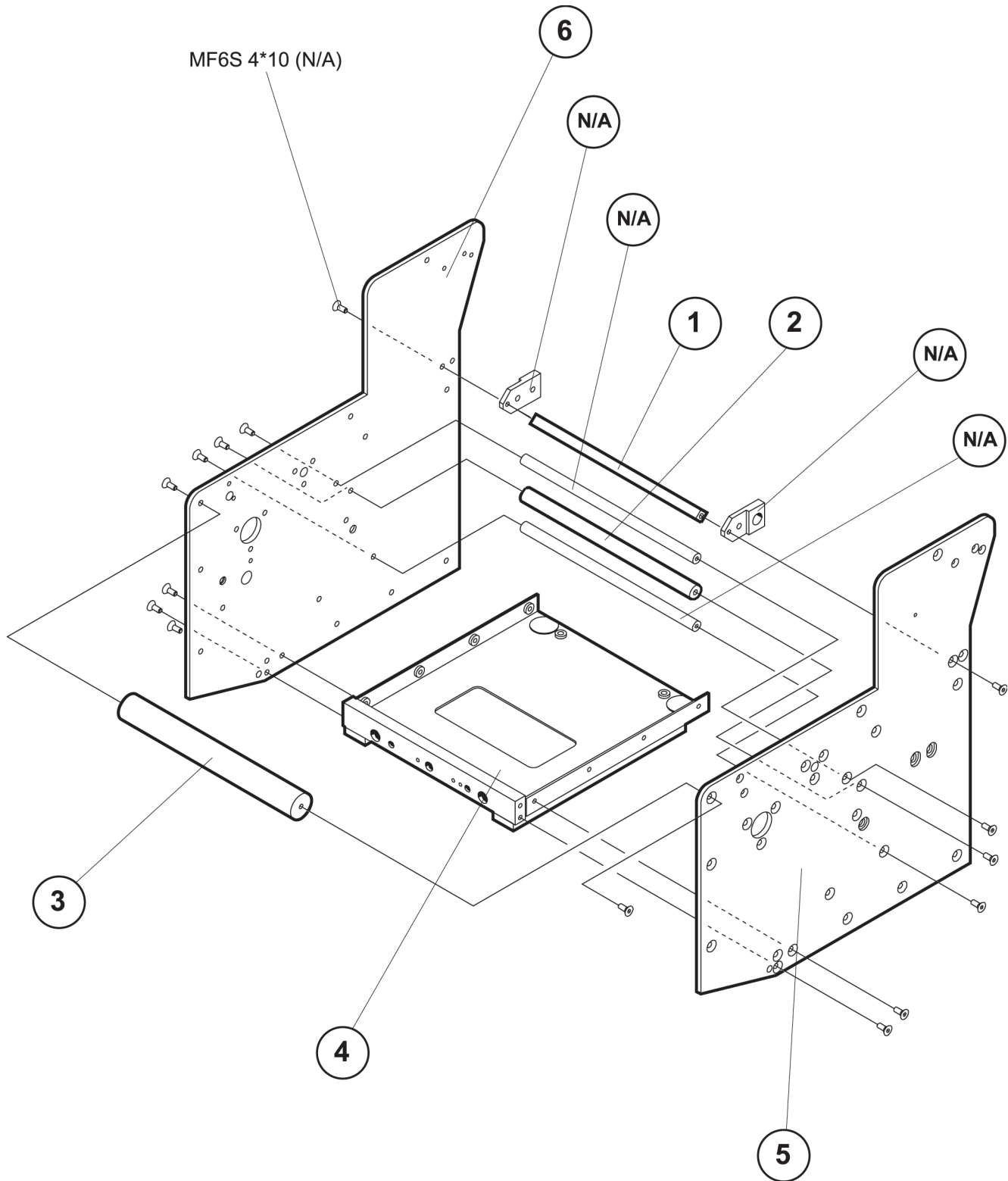

### Feeder number bar TM12C



Position: 1

Type of part:  
Mechanical component

Machine type:  
Magazine

Part no.	Product name
L-014-0221	Feeder number bar TM12C

### Feeder number bar TM8C



Position: 1

Type of part:  
Mechanical component

Machine type:  
Magazine

Part no.	Product name
L-014-0128	Feeder number bar TM8C

### Plastic axle



Position: 2

Type of part:  
Mechanical component

Description  
Axle where the feeder arms rest.

Machine type:  
Magazine

Part no.	Product name
D-014-0849-4	Plastic axle

### Handle



Position: 3

Type of part:  
Mechanical component

### Description

Handle for Tape Magazines.

Machine type:  
Magazine

Part no.	Product name
D-014-0664-4	Handle

### Bottom plate, magazine feeder unit complete

Position: 4

Type of part:  
Mechanical component

Machine type:  
Magazine

Part no.	Product name
L-014-0122	Bottom plate, magazine feeder unit complete

### Side Plate Flex Magazine - Left



Position: 5

Type of part:  
Unit

### Description

For TMD Flex magazine.

Machine type:  
Magazine

Part no.	Product name
L-014-0307	Side Plate Flex Magazine - Left

### Side plate, feeder unit - left

Position: 5

Type of part:  
Mechanical component

### Description

For all magazine types except TMD Flex and TM24D magazine.

Machine type:  
Magazine

Part no.	Product name
L-014-0121	Side plate, feeder unit - left

### Side Plate Flex Magazine - Right



Position: 6

Type of part:  
Unit

**Description**  
For TMD Flex magazine.

**Machine type:**  
Magazine

Part no.	Product name
L-014-0308	Side Plate Flex Magazine - Right

### Side plate, feeder unit - right



Position: 6

Type of part:  
Mechanical component

**Description**  
For all magazine types except TMD Flex and TM24D magazine.

**Machine type:**  
Magazine

Part no.	Product name
L-014-0120	Side plate, feeder unit - right



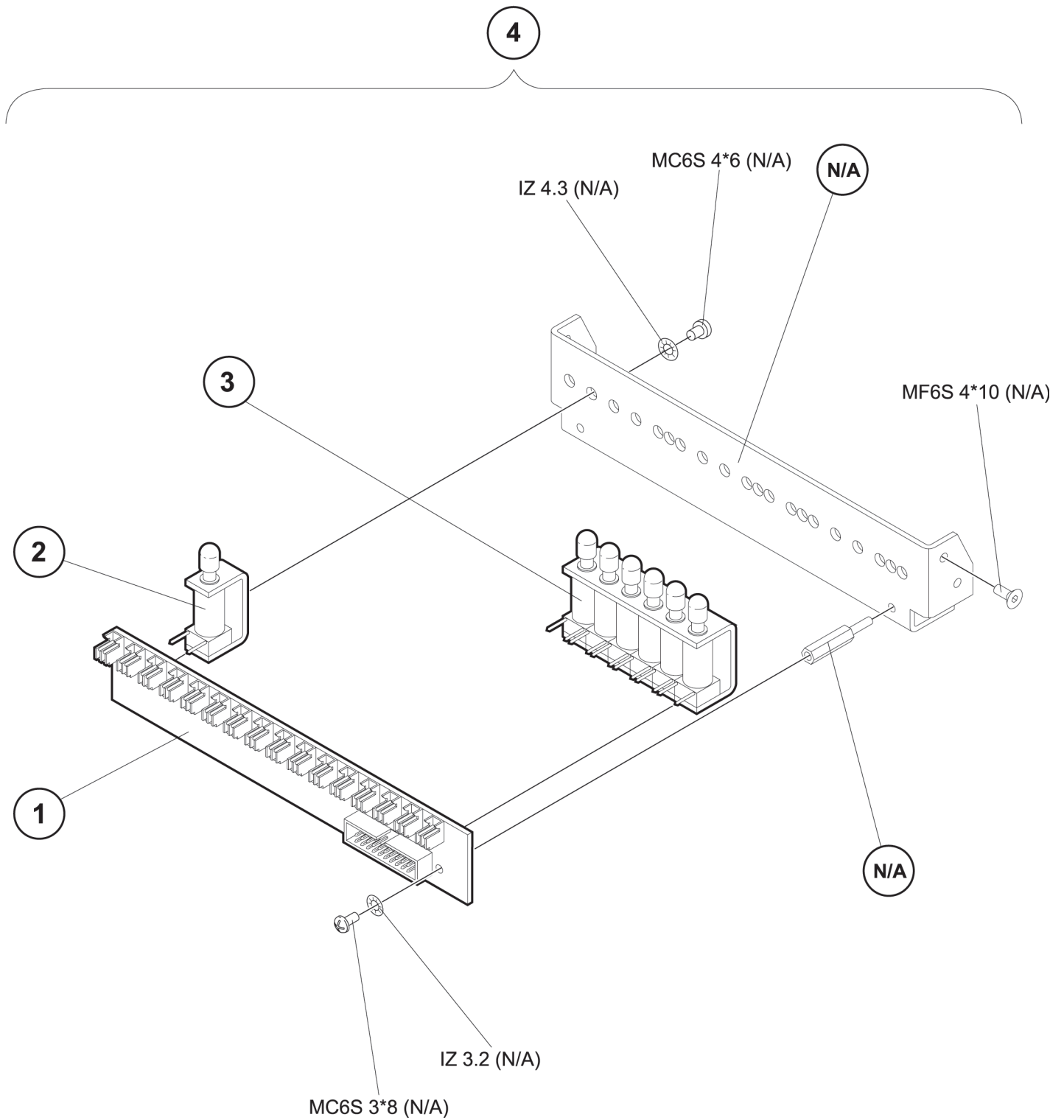

### TMC tape solenoid con. board



Position: 1

Type of part:  
PCB

#### Description

This board is a connection board for reel select solenoids.

#### Machine type:

Magazine

Part no.	Product name
L-019-0197-2	TMC tape solenoid con. board

### Feeder solenoid TM 1\*



Position: 2

Type of part:  
Electrical component

#### Description

For TM12(x)-, TM1216(x)-, TM16(x)-, TM24(x)-, TM32(x)-, TM44(x)- and TM5632(x) magazine.

#### Machine type:

Magazine

Part no.	Product name
K-014-0008	Feeder solenoid TM 1*

### Feeder solenoid TM 8



Position: 3

Type of part:  
Miscellaneous

Part is replacing:  
K-014-0009

#### Description

For TM8C, TM8FC and TMD Flex magazine.

#### Machine type:

Magazine

Part no.	Product name
K-014-0037-R	Feeder solenoid TM 8

### Push soleniod, 8-pack

Position: 3

Type of part:  
Miscellaneous

#### Part is replacing:

K-014-0037-R

#### Machine type:

Magazine

#### Ordering info:

For TM8C, TM8FC and TMD Flex magazine.

Part no.	Product name
U-014-0037	Push soleniod, 8-pack

### Solenoid unit TM8C



Position: 4

Type of part:  
Unit

#### Part is replacing:

L-014-0090

#### Description

Complete unit with 16 solenoids.

#### Machine type:

Magazine

Part no.	Product name
L-014-0090C	Solenoid unit TM8C

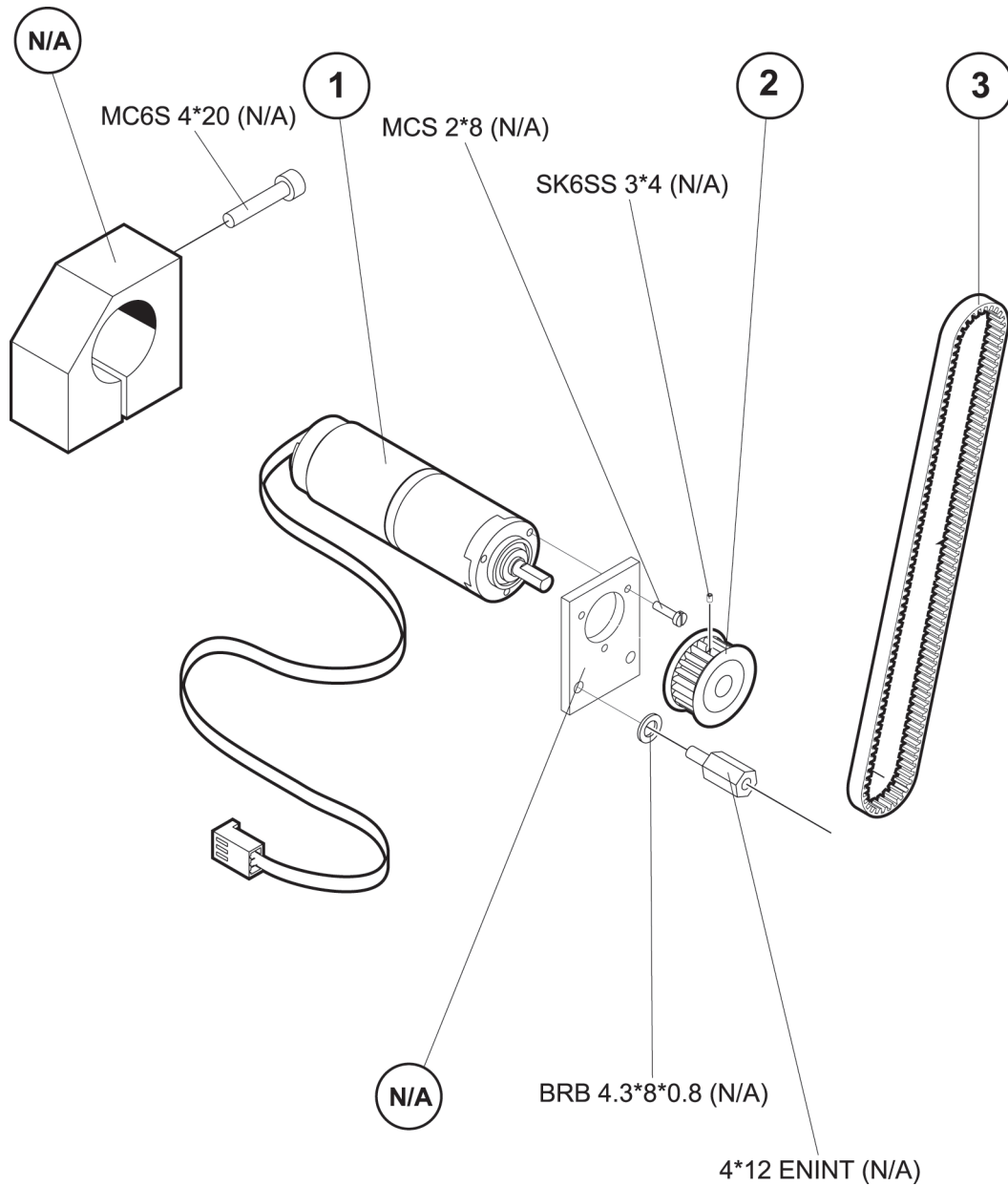



**24V DC motor + gear**



**Position:** 1  
**Type of part:** Motor  
**Part is replacing:** L-029-0507

**Description**  
 Uncover belt.

**Machine type:**  
 Magazine

Part no.	Product name
K-014-0024	Belt T2.5/317.5 B=4

**Description**  
 Feeder- and uncover motor

**Machine type:**  
 Magazine

**Requirements:**  
 TM - Tape magazine

Part no.	Product name
L-019-0106B	24V DC motor + gear

**Belt pulley**



**Position:** 2  
**Type of part:** Mechanical component

**Description**  
 Belt pulley for uncover motor.

**Machine type:**  
 Magazine

Part no.	Product name
D-014-0097-4	Belt pulley

**Belt T2.5/317.5 B=4**

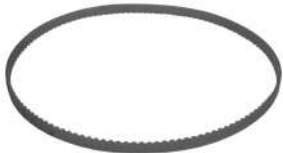

**Position:** 3  
**Type of part:** Belt

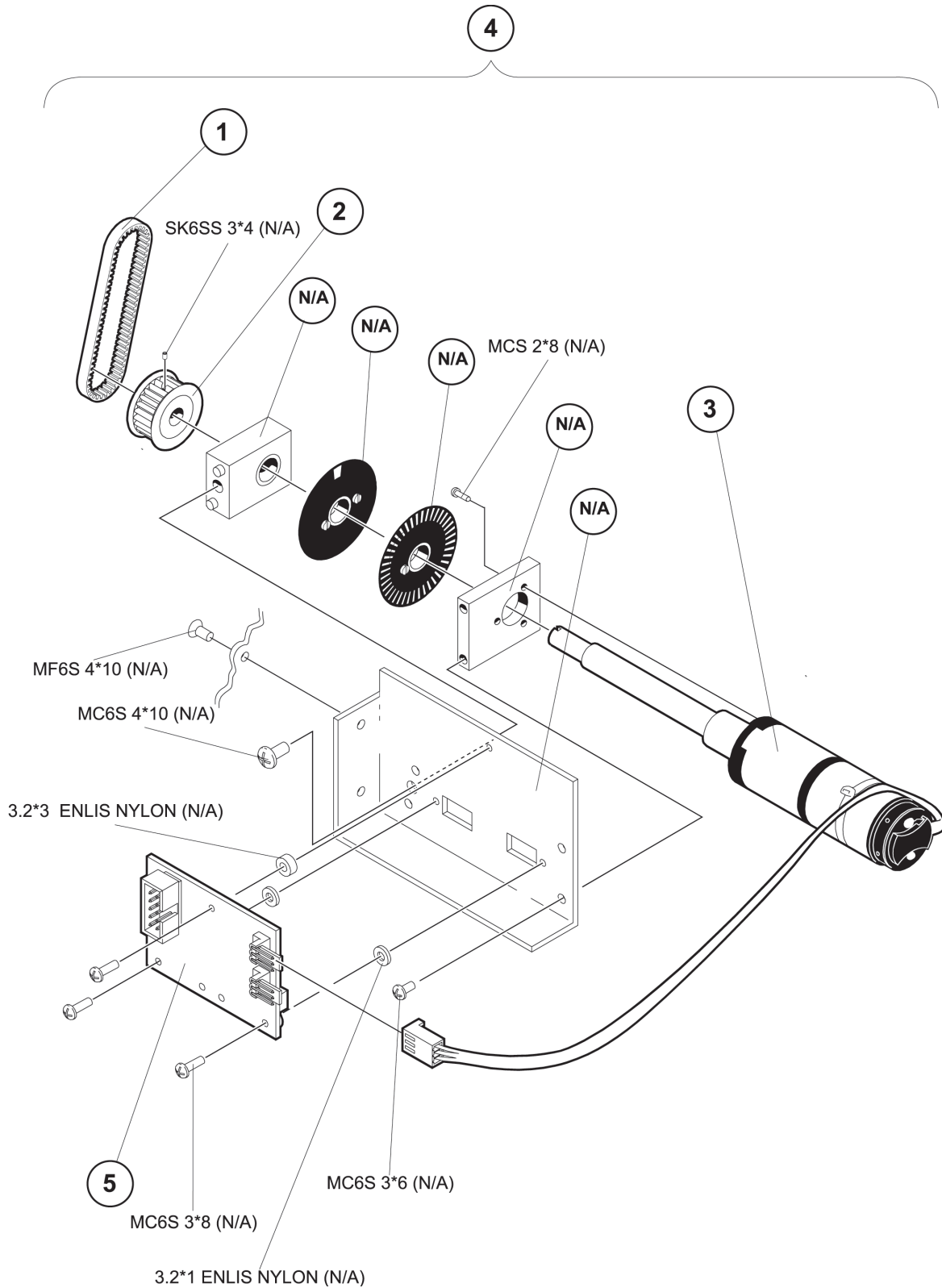

**Belt T2.5/145 B=3**



Position: 1

Type of part:  
Belt

**Description**  
Feeder belt.

**Machine type:**  
Magazine

Part no.	Product name
K-014-0022	Belt T2.5/145 B=3

**Belt pulley T2.5/24 B=10**



Position: 2

Type of part:  
Mechanical component

**Description**  
Belt pulley for feeder motor.

**Machine type:**  
Magazine

Part no.	Product name
D-014-0615-4	Belt pulley T2.5/24 B=10

**24V DC motor + gear**



Position: 3

Type of part:  
Motor

Part is replacing:  
L-029-0507

**Description**  
Feeder- and uncover motor

**Machine type:**  
Magazine

**Requirements:**  
TM - Tape magazine

Part no.	Product name
L-019-0106B	24V DC motor + gear

**Feeder motor unit**

Position: 4

Type of part:  
Unit

**Description**  
Complete feeder motor unit.

**Machine type:**  
Magazine

Part no.	Product name
L-014-0098	Feeder motor unit

**MS motor & sensor board TM**

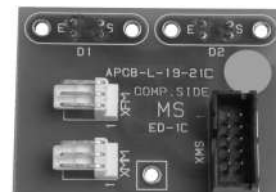

Position: 5

Type of part:  
PCB

Part is replacing:  
L-019-0021-1C

### Description

This board includes the position detection of the tape drive motor by two slotted opto-switches. You will also find the tape drive motor connections placed on the board.

### Machine type:

Magazine

Part no.	Product name
L-019-0021-1D	MS motor & sensor board TM



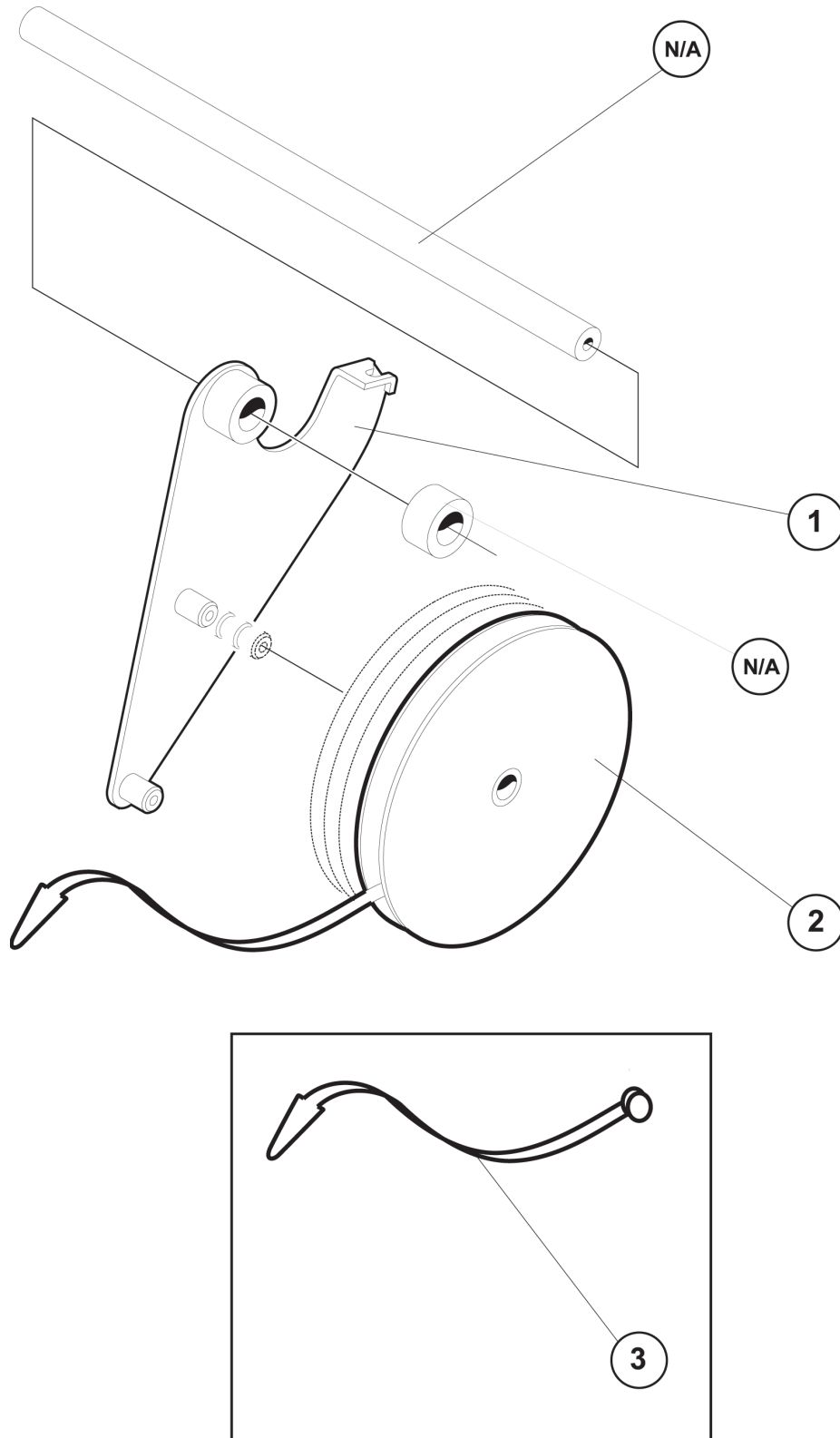

### Uncover wheel arm TM12C,16C



**Position:** 1  
**Type of part:**  
 Mechanical component

**Machine type:**  
 Magazine

Part no.	Product name
L-014-0138	Uncover wheel arm TM12C,16C

### Uncover wheel arm TM24D



**Position:** 1  
**Type of part:**  
 Mechanical component

**Machine type:**  
 Magazine

Part no.	Product name
L-014-0140	Uncover wheel arm TM24D

### Uncover wheel arm TM32D

**Position:** 1  
**Type of part:**  
 Mechanical component

**Machine type:**  
 Magazine

Part no.	Product name
L-014-0279	Uncover wheel arm TM32D

### Uncover wheel arm TM44D



**Position:** 1  
**Type of part:**  
 Mechanical component

**Machine type:**  
 Magazine

Part no.	Product name
L-014-0510	Uncover wheel arm TM44D

### Uncover wheel arm TM56D



**Position:** 1  
**Type of part:**  
 Mechanical component

**Machine type:**  
 Magazine

Part no.	Product name
L-014-0514	Uncover wheel arm TM56D

### Uncover wheel arm TM8C



**Position:** 1  
**Type of part:**  
 Mechanical component  
**Part is replacing:**  
 L-014-0095

**Machine type:**  
 Magazine

Part no.	Product name
L-014-0095C	Uncover wheel arm TM8C

### Uncover wheel string



**Position:** 2  
**Type of part:**  
 Mechanical component  
**Part is replacing:**  
 D-014-0435D-4

**Machine type:**  
 Magazine

Part no.	Product name
L-014-0518	Uncover wheel string

### Uncover wheel TM12C



**Position:** 2  
**Type of part:**  
 Mechanical component

**Description**  
 For Flex feeder use L-014-0405.

**Machine type:**  
 Magazine

Part no.	Product name
L-014-0141	Uncover wheel TM12C

### Uncover wheel TM16C



**Position:** 2  
**Type of part:**  
 Mechanical component

**Machine type:**  
 Magazine

Part no.	Product name
L-014-0142	Uncover wheel TM16C

### Uncover wheel TM24D



**Position:** 2  
**Type of part:**  
 Mechanical component

**Description**  
 For Flex feeder use L-014-0430.

**Machine type:**  
 Magazine

Part no.	Product name
L-014-0143	Uncover wheel TM24D

### Uncover wheel TM32D



**Position:** 2  
**Type of part:**  
 Mechanical component

**Description**  
 For Flex feeder use L-014-0899.

**Machine type:**  
 Magazine

Part no.	Product name
L-014-0280	Uncover wheel TM32D

### Uncover wheel TM44D



**Position:** 2  
**Type of part:**  
 Mechanical component

**Description**  
 For Flex feeder use L-014-0900.

**Machine type:**  
 Magazine

Part no.	Product name
L-014-0804	Uncover wheel TM44D

### Uncover wheel TM56D



**Position:** 2  
**Type of part:**  
 Mechanical component

**Description**  
 For Flex feeder use L-014-0901.

**Machine type:**  
 Magazine



Part no.	Product name
L-014-0805	Uncover wheel TM56D

### Uncover wheel TM8C



**Position:** 2

**Type of part:**  
Mechanical component

**Machine type:**  
Magazine

Part no.	Product name
L-014-0096	Uncover wheel TM8C

### Uncover wheel TM8C, plastic



**Position:** 2

**Type of part:**  
Mechanical component

**Description**  
For TM8C, TM8FC and 8mm Flex feeders.

**Machine type:**  
Magazine

Part no.	Product name
L-014-0460	Uncover wheel TM8C, plastic

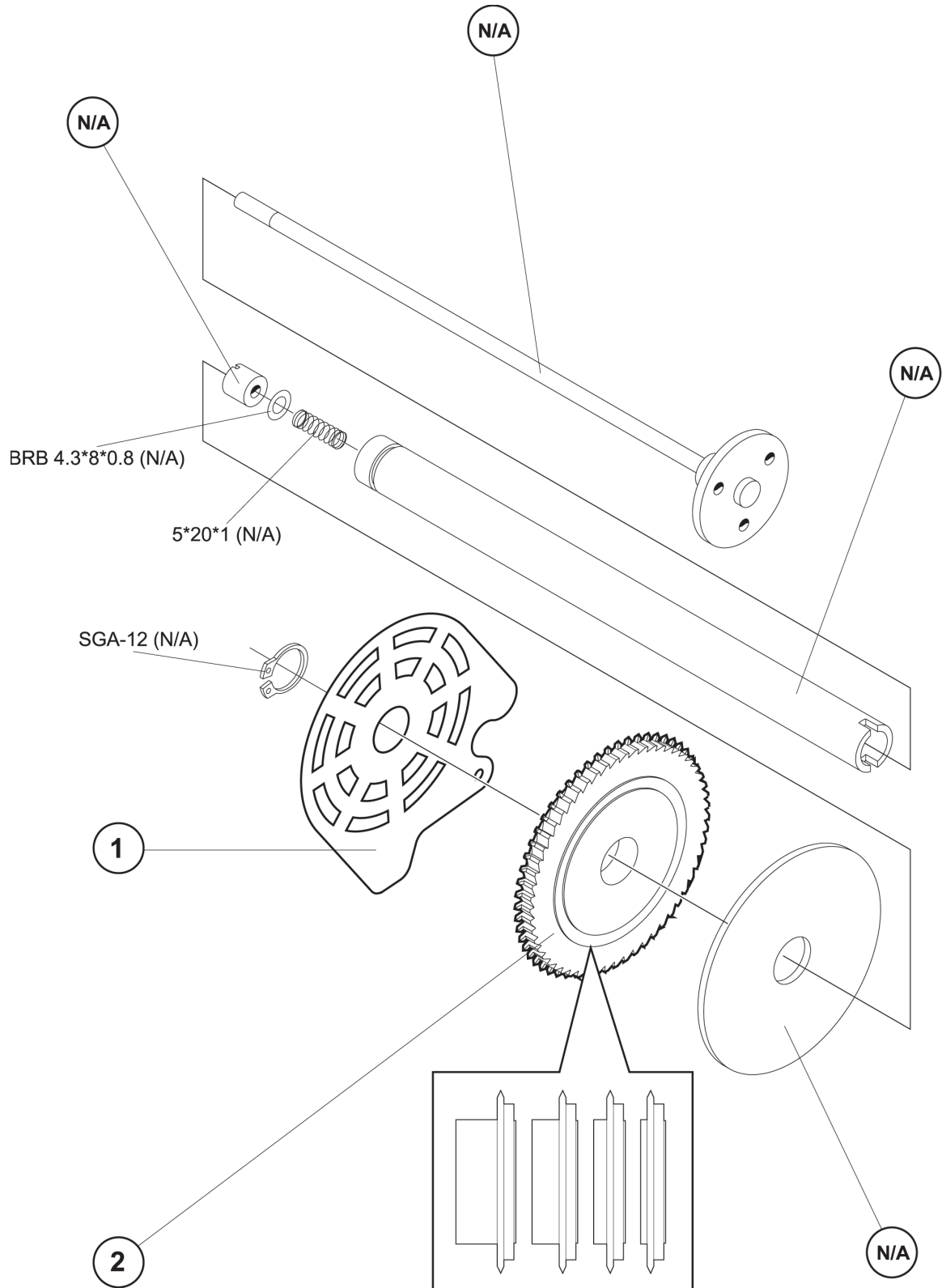

### Brake-disc for feeder wheel



**Position: 1**  
**Type of part:**  
 Mechanical component

**Description**

Brake disc between feeder wheels.

**Machine type:**

Magazine

Part no.	Product name
D-014-0617-3	Brake-disc for feeder wheel

### Feeder wheel



**Position: 2**  
**Type of part:**  
 Mechanical component

**Description**

This feeder wheel is used in TM8C, TM12C, TM16C, TM24C/D and TM12/16C

**Machine type:**

Magazine

**Requirements:**

When using this part to replace old (white) feeder wheel it is also required a spacer ring to make a complete feeder wheel. Use it together with D-014-0853B-3 to make a complete TM8B feeder wheel to replace L-014-0250. Use it together with D-014-0858-3 to make a complete TM12B feeder wheel to replace L-014-0251.

Use it together with D-014-0859-3 to make a complete TM16B feeder wheel to replace L-014-0252. Use it together with D-014-0860-3 to make a complete TM24B feeder wheel to replace L-014-0253.

Part no.	Product name
D-014-0852-2	Feeder wheel

### Feeder wheel TM8FC



**Position: 2**  
**Type of part:**  
 Mechanical component

**Description**

Feeder wheel for Fine Pitch magazine.

**Machine type:**

Magazine

Part no.	Product name
D-014-0851-2	Feeder wheel TM8FC

### Spacer for TM12C feeder wheel



**Position: 2**  
**Type of part:**  
 Mechanical component

**Machine type:**

Magazine

**Requirements:**

Together with D-014-0852-2 make a complete feeder wheel for TM12C to replace L-014-0251.

Part no.	Product name
D-014-0858-3	Spacer for TM12C feeder wheel

### Spacer for TM16C feeder wheel



**Position: 2**  
**Type of part:**  
 Mechanical component

**Machine type:**

Magazine

**Requirements:**

Together with D-014-0852-2 make a complete feeder wheel for TM16C to replace L-014-0252.

Part no.	Product name
D-014-0859-3	Spacer for TM16C feeder wheel

**Spacer for TM24C feeder wheel**



**Position:** 2

**Type of part:**  
Mechanical component

**Part is replacing:**  
L-014-0253

**Description**

Together with D-014-0852-2 make a complete feeder wheel for TM24C to replace L-014-0253.

**Machine type:**

Magazine

Part no.	Product name
D-014-0860-3	Spacer for TM24C feeder wheel

**Spacer for TM24D feeder wheel**



**Position:** 2

**Type of part:**  
Mechanical component

**Machine type:**

Magazine

**Requirements:**

Together with D-014-0852-2 make a complete feeder wheel for TM24D.

Part no.	Product name
D-014-1057-3	Spacer for TM24D feeder wheel

**Spacer for TM8C feeder wheel**



**Position:** 2

**Type of part:**  
Mechanical component

**Machine type:**

Magazine

**Requirements:**

Together with D-014-0852-2 make a complete feeder wheel for TM8C to replace L-014-0250.

Part no.	Product name
D-014-0853B-3	Spacer for TM8C feeder wheel



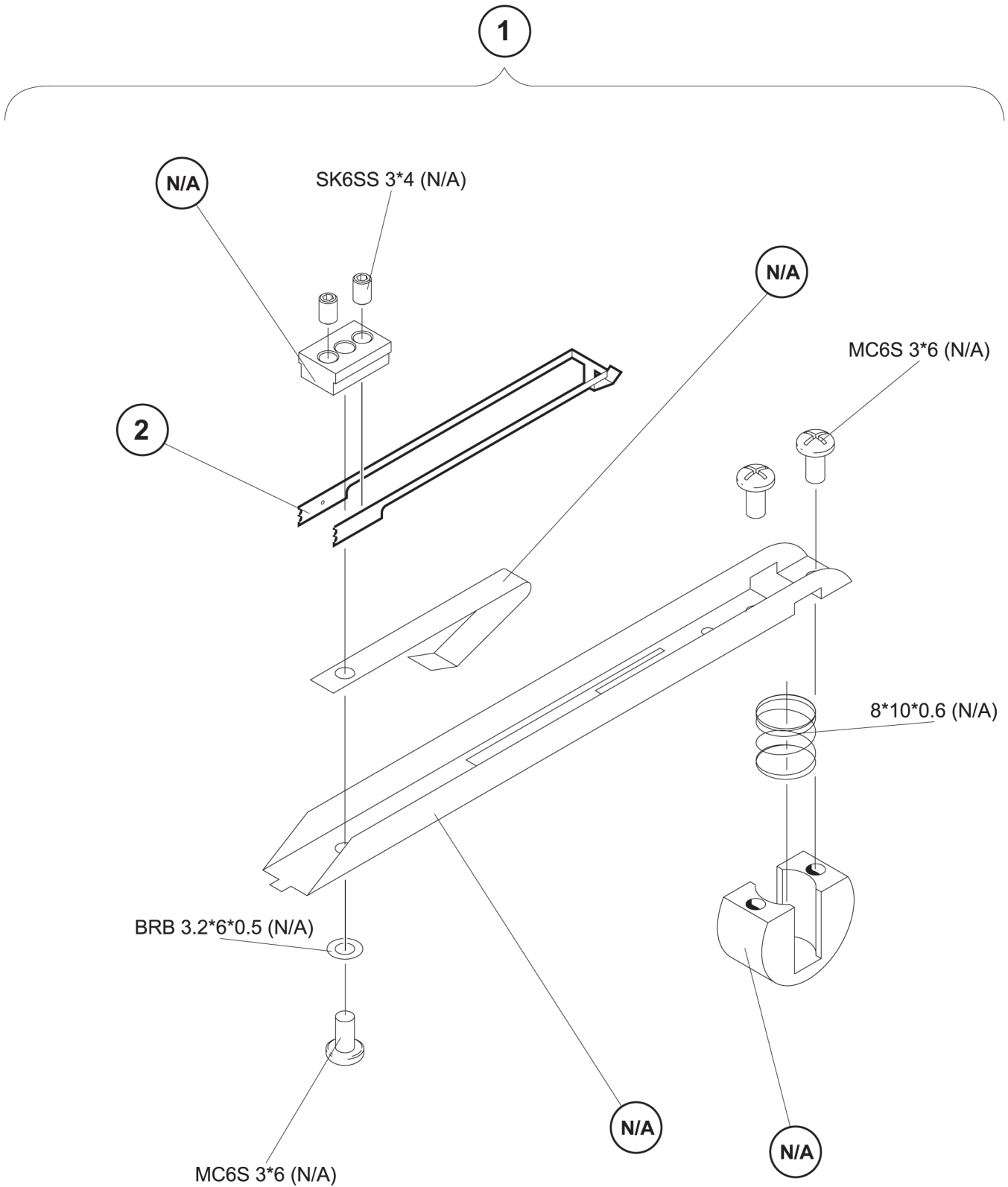

### Tape holder arm TM12C



Position: 1

Type of part:  
Unit

Machine type:  
Magazine

Part no.	Product name
L-014-0214	Tape holder arm TM12C

### Tape holder arm TM8FC



Position: 1

Type of part:  
Mechanical component

Machine type:  
Magazine

Part no.	Product name
L-014-0446	Tape holder arm TM8FC

### Tape holder arm TM16C



Position: 1

Type of part:  
Unit

Machine type:  
Magazine

Part no.	Product name
L-014-0215	Tape holder arm TM16C

### Component separator spring TM8C



Position: 2

Type of part:  
Mechanical component

Part is replacing:  
L-014-0148

Machine type:  
Magazine

Part no.	Product name
L-014-0910	Component separator spring TM8C

### Tape holder arm TM24D



Position: 1

Type of part:  
Unit

Machine type:  
Magazine

Part no.	Product name
L-014-0216	Tape holder arm TM24D

### Component separator spring TM8FC



Position: 2

Type of part:  
Mechanical component

Description  
For Fine Pitch magazine.

Machine type:  
Magazine

Part no.	Product name
L-014-0445	Component separator spring TM8FC

### Tape holder arm TM8C



Position: 1

Type of part:  
Unit

Machine type:  
Magazine

Part no.	Product name
L-014-0114	Tape holder arm TM8C

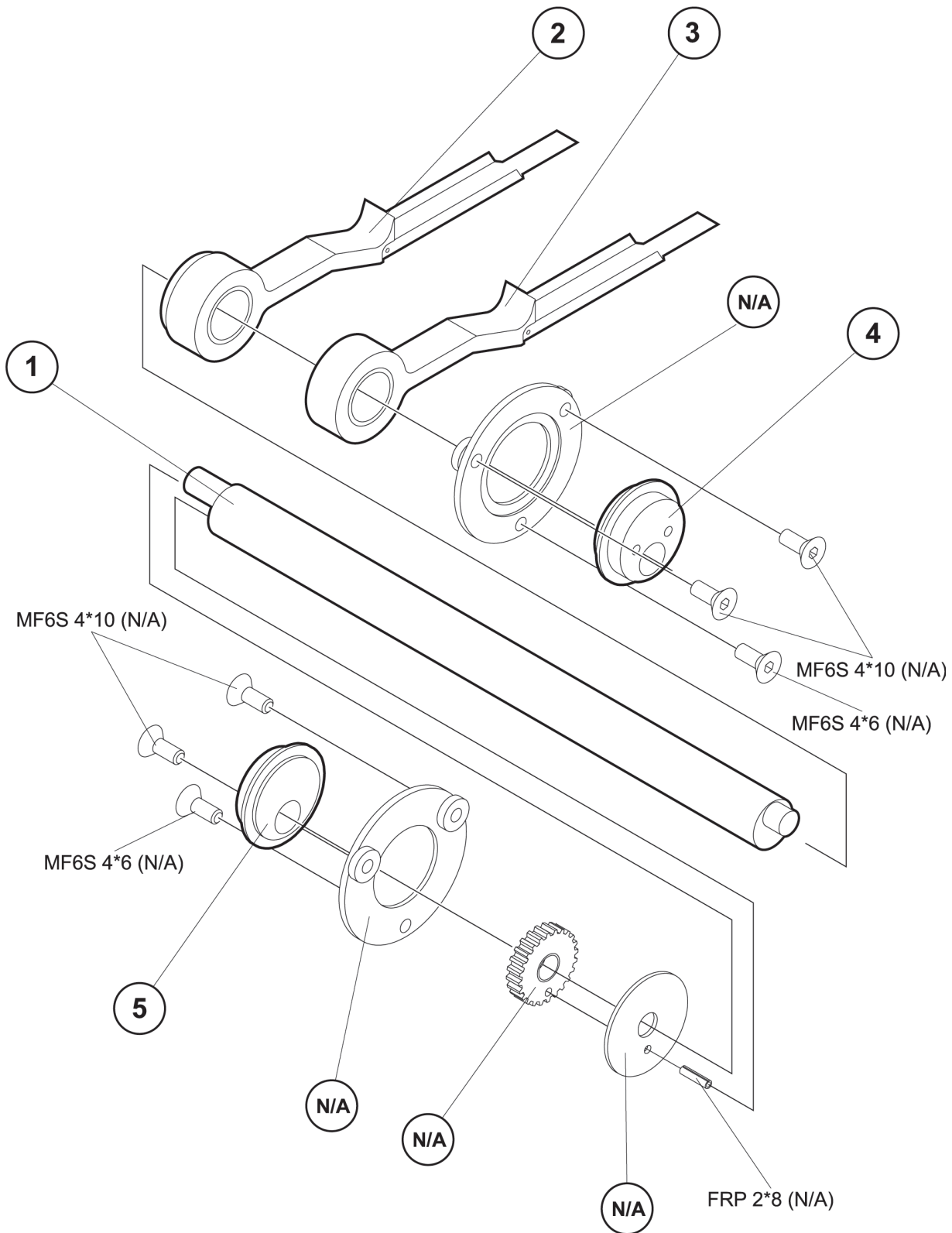



### Drive axle complete



**Position:** 1  
**Type of part:**  
Mechanical component

**Machine type:**  
Magazine

Part no.	Product name
L-014-0105	Drive axle complete

**Description**  
15 pieces used in TM8FC.

**Machine type:**  
Magazine

Part no.	Product name
L-014-0299	Feeder arm, Fine Pitch

### Feeder arm, drive side



**Position:** 2  
**Type of part:**  
Mechanical component  
**Part is replacing:**  
L-014-0107B

**Description**  
1 piece used in TM8C, TMD Flex and TM24D.

**Machine type:**  
Magazine

Part no.	Product name
L-014-0107C	Feeder arm, drive side

### Feeder arm, standard



**Position:** 3  
**Type of part:**  
Mechanical component  
**Part is replacing:**  
L-014-0106B

**Description**  
15 pieces used in TM8C and TMD Flex.  
8 pieces used in TM12C, TM16C and TM12/16C.  
5 pieces used in TM24D.  
4 pieces used in TM32D.  
3 pieces used in TM44D and TM5632D.

**Machine type:**  
Magazine

Part no.	Product name
L-014-0106C	Feeder arm, standard

### Feeder arm, Fine Pitch



**Position:** 2  
**Type of part:**  
Mechanical component

**Description**  
1 piece used in TM8FC.

**Machine type:**  
Magazine

Part no.	Product name
L-014-0300	Feeder arm, Fine Pitch

### Eccentric bushing, right



**Position:** 4  
**Type of part:**  
Mechanical component

**Machine type:**  
Magazine

Part no.	Product name
L-014-0230	Eccentric bushing, right

### Feeder arm, Fine Pitch



**Position:** 3  
**Type of part:**  
Mechanical component

**Eccentric bushing, left**



**Position:** 5

**Type of part:**  
Mechanical component

**Machine type:**  
Magazine

<b>Part no.</b>	<b>Product name</b>
L-014-0229	Eccentric bushing, left



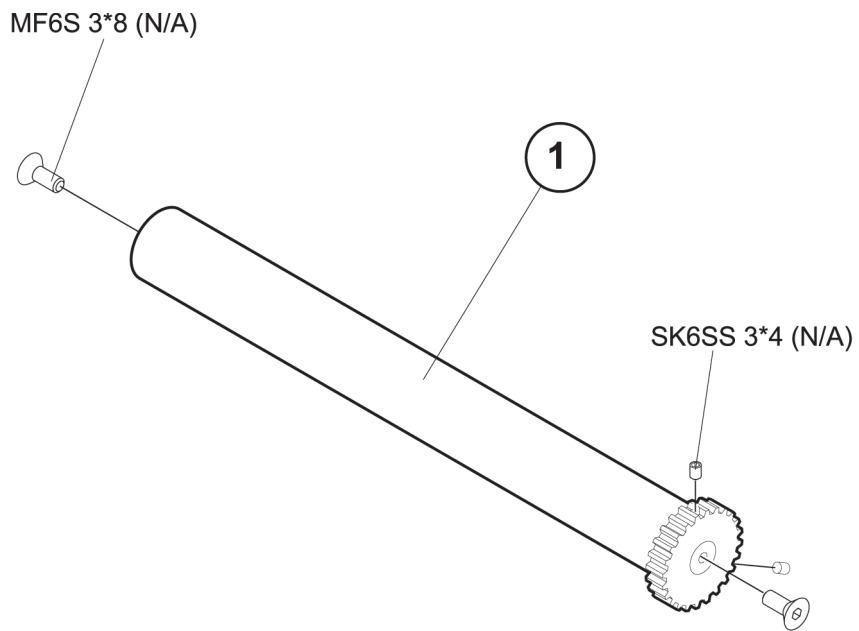

### Uncover roller complete



Position: 1

Type of part:  
Mechanical component

Machine type:  
Magazine

Part no.	Product name
L-014-0101	Uncover roller complete

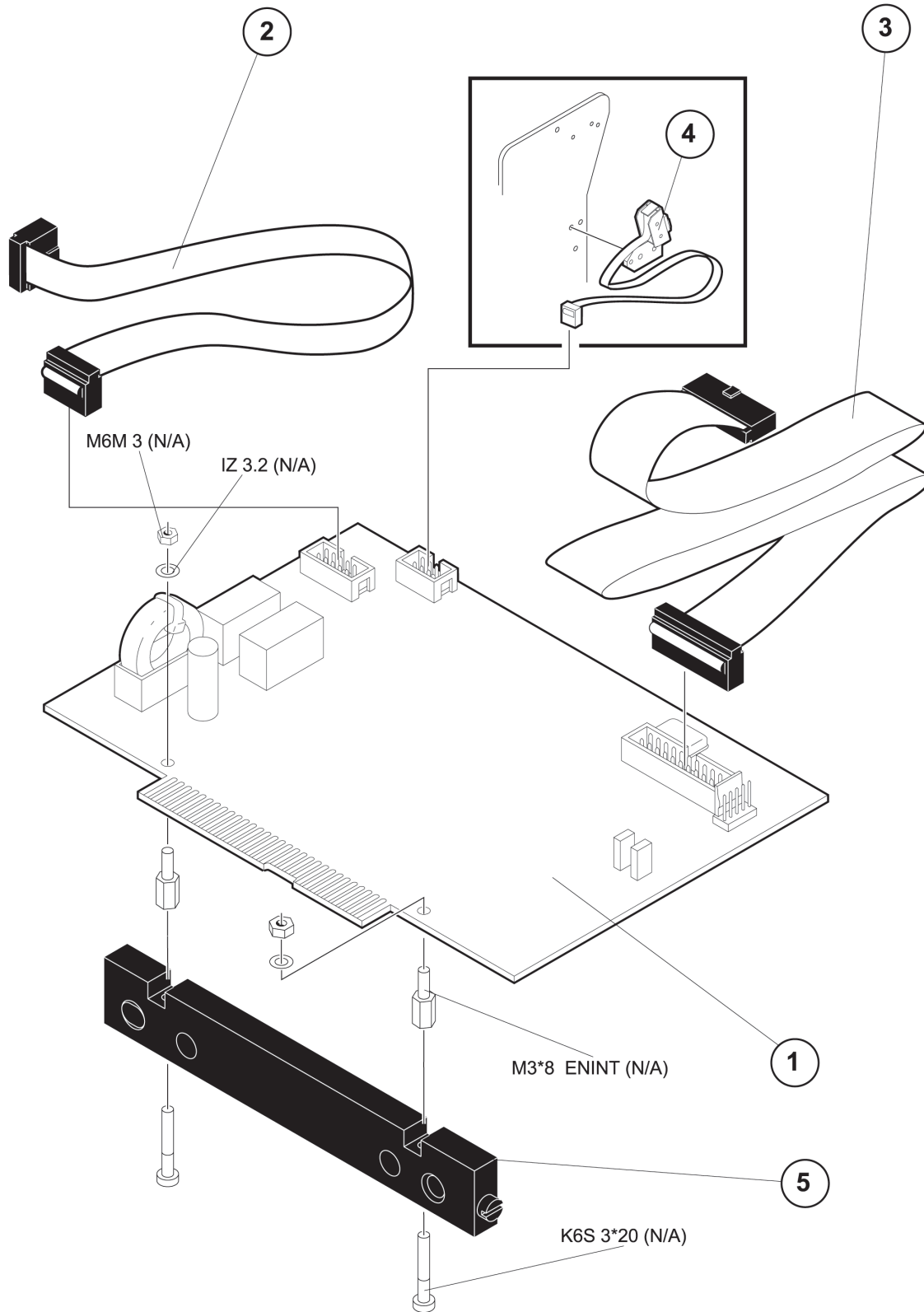

### XMS motor & sensor cable



Position: 2  
Type of part:  
Cable

**Description**  
Cable from TC(x) board to MS-board.

**Machine type:**  
Magazine

Part no.	Product name
L-019-0205	XMS motor & sensor cable

### XDM drive magnets cable

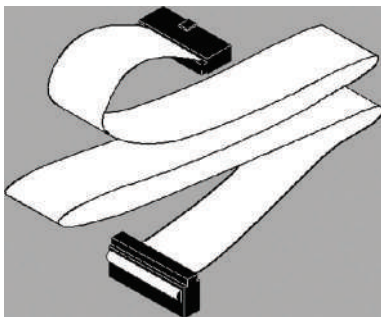

Position: 3  
Type of part:  
Cable

**Description**  
Cable from TC(x) board to TMC board.

**Machine type:**  
Magazine

Part no.	Product name
L-019-0206	XDM drive magnets cable

### Magazine button and bracket



Position: 4  
Type of part:  
Cable

**Machine type:**  
Magazine

Part no.	Product name
L-014-0465	Magazine button and bracket

### Support beam complete



Position: 5  
Type of part:  
Mechanical component

**Machine type:**  
Magazine

Part no.	Product name
L-014-0124	Support beam complete

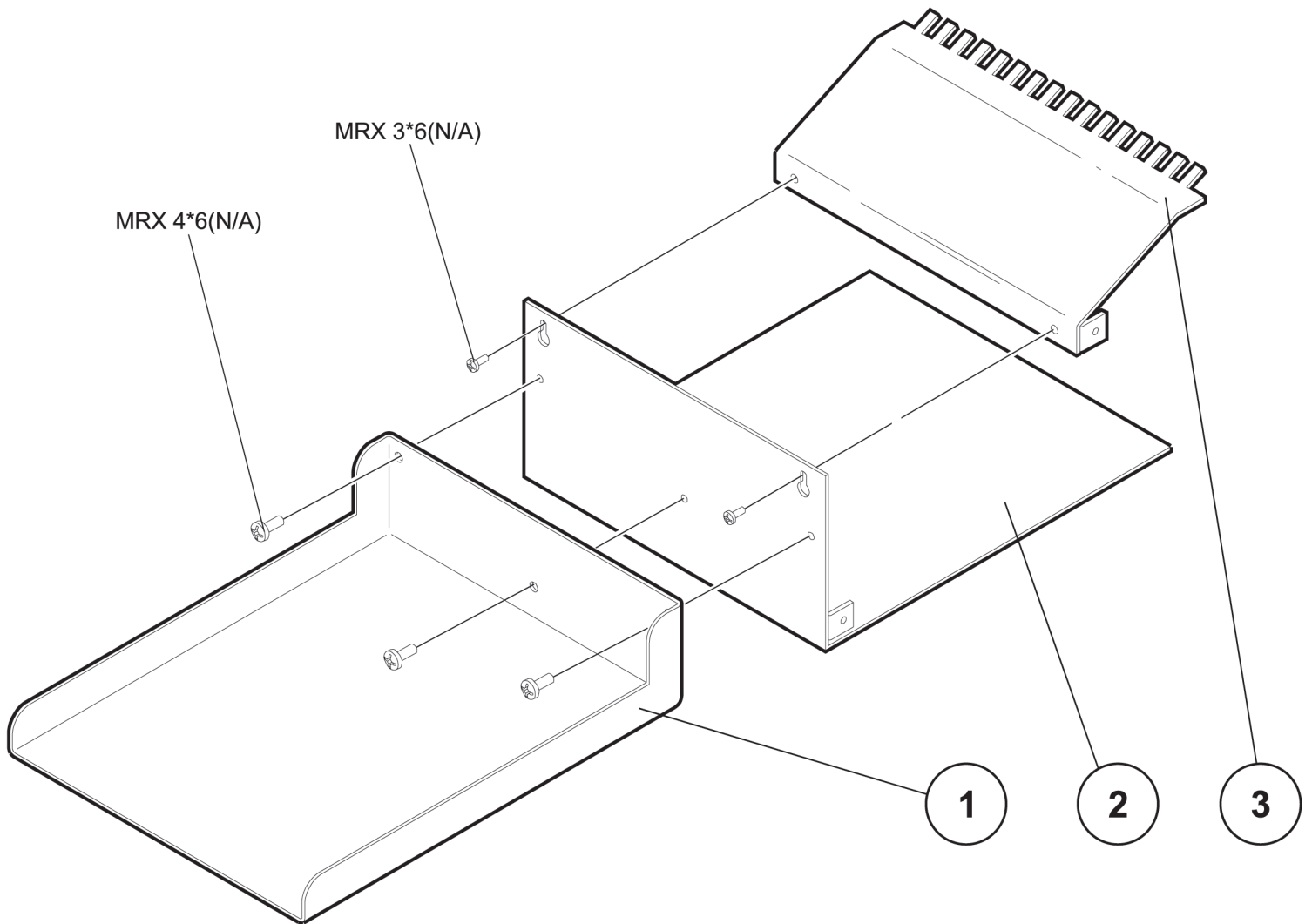



### Tape guide plate



**Position: 1**  
**Type of part:**  
 Mechanical component

**Description**

Tape guide that prevents component tapes from entering magazine slots.

**Machine type:**  
 Magazine

Part no.	Product name
D-014-0685-2	Tape guide plate

**Machine type:**  
 Magazine

Part no.	Product name
L-014-0125	Cover plate complete

### Slit plate complete TM24D



**Position: 2**  
**Type of part:**  
 Mechanical component

**Machine type:**  
 Magazine

Part no.	Product name
L-014-0220	Slit plate complete TM24D

### Tape guide plate

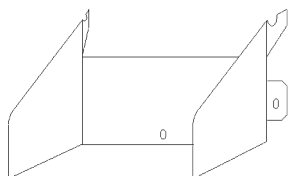

**Position: 1**  
**Type of part:**  
 Mechanical component

**Description**

Tape guide that prevent component tapes from entering magazine slots. Only for machines equipped with Tray Elevator.

**Machine type:**  
 Magazine , Tray Elevator

**Requirements:**  
 Tray Elevator

Part no.	Product name
D-014-0685B-2	Tape guide plate

### Outflow plate TMD Flex/TM8FC magazine



**Position: 3**  
**Type of part:**  
 Mechanical component

**Machine type:**  
 Magazine

Part no.	Product name
L-014-0408	Outflow plate TMD Flex/TM8FC magazine

### Slit plate complete TM1216C



**Position: 3**  
**Type of part:**  
 Mechanical component

**Machine type:**  
 Magazine

Part no.	Product name
L-014-0219	Slit plate complete TM1216C

### Cover plate complete



**Position: 2**  
**Type of part:**  
 Mechanical component

### Slit plate complete TM12C



**Position:** 3  
**Type of part:**  
 Mechanical component

**Machine type:**  
 Magazine

Part no.	Product name
L-014-0217	Slit plate complete TM12C

### Slit plate complete TM16C



**Position:** 3  
**Type of part:**  
 Mechanical component

**Machine type:**  
 Magazine

Part no.	Product name
L-014-0218	Slit plate complete TM16C

### Slit plate complete TM5632D



**Position:** 3  
**Type of part:**  
 Mechanical component

**Machine type:**  
 Magazine

Part no.	Product name
L-014-0503	Slit plate complete TM5632D

### Slit plate complete TM8C



**Position:** 3  
**Type of part:**  
 Mechanical component

**Machine type:**  
 Magazine

Part no.	Product name
L-014-0113	Slit plate complete TM8C

### Feeder wheel 12 - 24 mm



**Description**  
 For 12mm Flex magazine feeders.

Part no.	Product name
L-014-0251	Feeder wheel 12mm
L-014-0252	Feeder wheel 16mm

### Magazine PAL



**Ordering info:**  
 Please state serial number written on the PAL when ordering.

Part no.	Product name
L-029-0488G	MY104g PAL WMF30
L-029-0492I	MY104i PAL TM12
L-029-0490I	MY104i PAL TM1216
L-029-0493I	MY104i PAL TM16
L-029-0491I	MY104i PAL TM24
L-029-0494I	MY104i PAL TM32
L-029-0495I	MY104i PAL TM44
L-029-0496I	MY104i PAL TM5632
L-029-0489I	MY104i PAL TM8
L-029-0497I	MY104i PAL TM8F
L-029-0501I	MY104i PAL TMFlex

### Tape holder arm, Flex feeder



#### Description

Part no.	Product name
L-014-0431	Tape holder arm, Flex 12mm
L-014-0911	Tape holder arm, Flex 24mm
L-014-0650	Tape holder arm, Flex 32mm
L-014-0718	Tape holder arm, Flex 44mm
L-014-0657	Tape holder arm, Flex 56mm

### Uncover wheel arm, Flex feeder

Part no.	Product name
L-014-0407	Uncover wheel arm, Flex 8mm
L-014-0404	Uncover wheel arm, Flex 12mm
L-014-0409	Uncover wheel arm, Flex 16mm
L-014-0427	Uncover wheel arm, Flex 24 mm

### Uncover wheel, Flex feeder

#### Description

Part no.	Product name
L-014-0405	Uncover wheel, Flex 12mm
L-014-0430	Uncover wheel, Flex 24mm
L-014-0899	Uncover wheel, Flex 32mm
L-014-0900	Uncover wheel, Flex 44mm
L-014-0901	Uncover wheel, Flex 56mm

### Washer



#### Description

Washer for magazine positioner

Part no.	Product name
K-041-0021	Washer 0.2 mm
K-041-0022	Washer 0.025 mm

### Belt AT3/150 W=3



Type of part:  
Belt

#### Description

Uncover belt

#### Machine type:

Magazine

#### Requirements:

Agilis

Part no.	Product name
K-014-0065	Belt AT3/150 W=3

### Belt T2.5/120 B=6



Type of part:  
Belt

Part is replacing:  
K-014-0002

#### Description

For Fi axis, 270, 450 & 420PT conveyors.

#### Machine type:

TP9-1 , TP9-2 , Magazine

Part no.	Product name
K-012-0002	Belt T2.5/120 B=6

### XMIB4 cable

#### Type of part:

Cable

**Machine type:**  
MY9 , MY12 , MY15 , MY19

Part no.	Product name
L-049-0232	XMIB4 cable

**XMIBOX cable**



**Type of part:**  
Cable

**Description**  
Cable from Computer Box to Magazine interface bus cable (XMIBUS).

**Machine type:**  
TP9-1

Part no.	Product name
L-019-0094	XMIBOX cable

**XMIBOX cable**

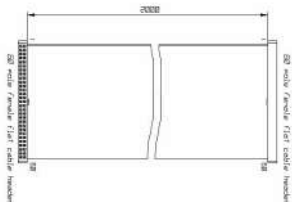

**Type of part:**  
Cable

**Description**  
Cable from Computer Box to XMIBUS cable (XMIBUS).

**Machine type:**  
TP11

Part no.	Product name
L-019-0529	XMIBOX cable

**XMIBOX cable**

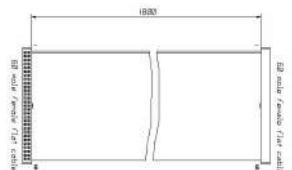

**Type of part:**  
Cable

**Description**  
Cable from Computer Box to Magazine interface bus cable (XMIBUS).

**Machine type:**  
TP9-2

Part no.	Product name
L-019-0414	XMIBOX cable

**XMIBUS cable**

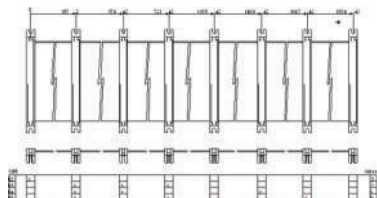

**Type of part:**  
Cable

**Part is replacing:**  
L-019-0095

**Description**  
Magazine interface bus cable. Cable between all magazine slots.

**Machine type:**  
TP9-1 , TP9-2 , TP9-3 , TP9-4

Part no.	Product name
L-019-0095B	XMIBUS cable

**XMIBUS cable**

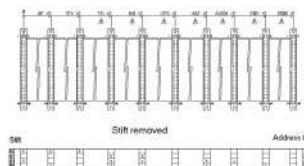

**Type of part:**  
Cable

**Part is replacing:**  
L-019-0527

**Description**  
Magazine interface bus cable. Cable between all magazine slots.

**Machine type:**  
TP11

Part no.	Product name
L-019-0527B	XMIBUS cable

### XMIBUS cable left

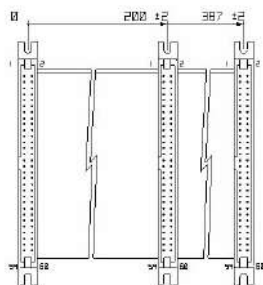

**Type of part:**  
Cable

**Description**  
Left XMIBUS cable section.

**Machine type:**  
TP12

Part no.	Product name
L-029-0103	XMIBUS cable left

**Description**  
Outer left XMIBUS cable section.

**Machine type:**  
TP18

Part no.	Product name
L-029-0100	XMIBUS cable left, outer

### XMIBUS cable right

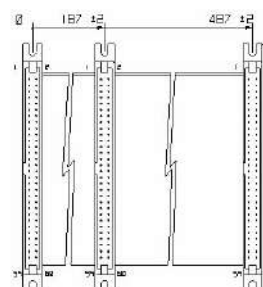

**Type of part:**  
Cable

**Description**  
Right XMIBUS cable section.

**Machine type:**  
TP12

Part no.	Product name
L-029-0104	XMIBUS cable right

### XMIBUS cable left, inner

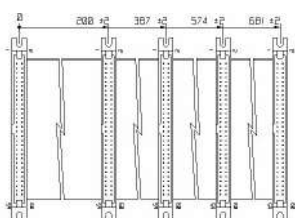

**Type of part:**  
Cable

**Description**  
Inner left XMIBUS cable section.

**Machine type:**  
TP18

Part no.	Product name
L-029-0099	XMIBUS cable left, inner

**Description**  
Right XMIBUS cable section.

**Machine type:**  
TP12

Part no.	Product name
L-029-0104	XMIBUS cable right

### XMIBUS cable right, inner

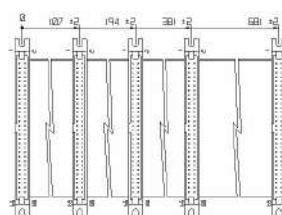

**Type of part:**  
Cable

**Description**  
Inner right XMIBUS cable section.

**Machine type:**  
TP18

Part no.	Product name
L-029-0101	XMIBUS cable right, inner

### XMIBUS cable left, outer

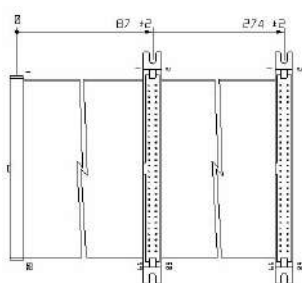

**Type of part:**  
Cable

**XMIBUS cable right, outer**

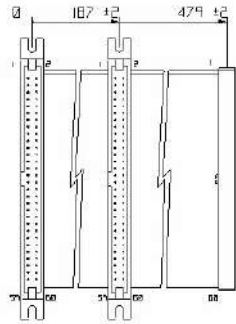

**Type of part:**  
Cable

**Description**  
Outer right XMIBUS cable section.

**Machine type:**  
TP18

Part no.	Product name
L-029-0102	XMIBUS cable right, outer

**Description**  
Magazine position connector cable.

**Machine type:**  
TP9-1 , TP9-2 , TP9-3 , TP9-4 , TP11 , TP12 , TP18

Part no.	Product name
L-019-0093B	XMIF cable

**XMIF2 cable**

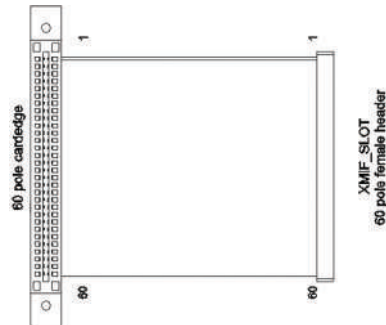

**Type of part:**  
Cable

**Description**  
Magazine position connector.

**Machine type:**  
MY9 , MY12 , MY15 , MY19

Part no.	Product name
L-049-0062	XMIF2 cable

**XMIBUS cable, middle**

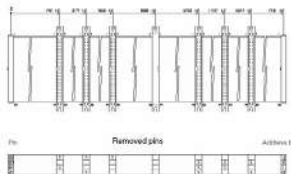

**Type of part:**  
Cable

**Description**  
Middle XMIBUS cable section.

**Machine type:**  
TP12 , TP18

Part no.	Product name
L-029-0098	XMIBUS cable, middle

**74LS244**



**Type of part:**  
Electrical component

**Description**  
Used on IC19, IC20 ,IC21 on MI-board.

**Machine type:**  
MY12 , MY15 , MY19 , MY9 , TP11 , TP12 , TP18 , TP9-1 , TP9-2 , TP9-3 , TP9-4

Part no.	Product name
SH74LS244	74LS244

**XMIF cable**

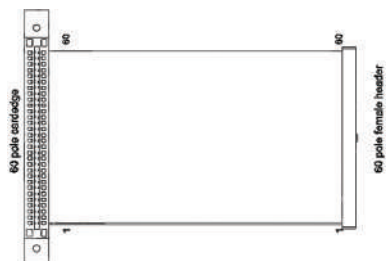

**Type of part:**  
Cable

### 8x400 mA 90V Darlington driver



**Type of part:**  
Electrical component

**Description**

Used on IC5, IC12, IC35 & IC36 on MI-board. IC4 on XWB board

**Machine type:**

TP9-1 , TP9-2 , TP9-3 , TP9-4 , TP11 , TP12 , TP18

Part no.	Product name
SHL603	8x400 mA 90V Darlington driver

### Vibrator



**Type of part:**  
Electrical component

**Part is replacing:**  
K-014-0012

**Description**

Vibrator for VMF30 magazine.

**Machine type:**

Magazine

Part no.	Product name
K-014-0012B	Vibrator

### XTF VMF trafo cable



**Type of part:**  
Electrical component

**Description**

For Vibratory Magazine - VMF30.

**Machine type:**

Magazine

Part no.	Product name
L-019-0139	XTF VMF trafo cable

### Feeder wheel 32 - 56



Part no.	Product name
L-014-0890	Feeder wheel TM32D
L-014-0891	Feeder wheel TM44D
L-014-0892	Feeder wheel TM56D

### Agilis control board - QMC

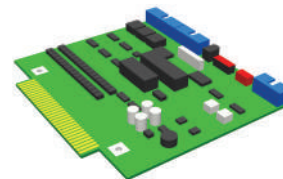

**Type of part:**  
Kit

**Part is replacing:**  
L-014-1364

**Description**

Control board for Agilis board. Including functionality.

- Serial number and magazine type
- Decoding for slot position
- Reading feeder status
- Controlling green/yellow LED panel
- Solenoid safety diodes
- Reading opto encoders

**Machine type:**

Magazine

**Requirements:**

Agilis LM8, LM1216 or M8 magazine

Part no.	Product name
L-014-1364B	Agilis control board - QMC

### Agilis Drive Unit Frame



Type of part:  
Kit

Machine type:  
Magazine

Part no.	Product name
L-014-1338	Agilis Drive Unit Frame

### Agilis Feeder Wheel Set



Type of part:  
Kit

**Description**

8 feeder wheels with extra kit of locking springs.

Machine type:  
Magazine

Part no.	Product name
L-014-1341	Agilis Feeder Wheel Set

### Agilis Drive Unit mount



Type of part:  
Kit

**Description**

Means of attachment for the drive unit in the magazine.

Machine type:  
Magazine

Part no.	Product name
L-014-1328	Agilis Drive Unit mount

### Agilis Feeder Wheel Unit



Type of part:  
Kit

Machine type:  
Magazine

Part no.	Product name
L-014-1331	Agilis Feeder Wheel Unit

### Agilis Eccentric Shaft



Type of part:  
Kit

Machine type:  
Magazine

Part no.	Product name
L-014-1335	Agilis Eccentric Shaft

### Agilis interconnection board kit - QM16FIB

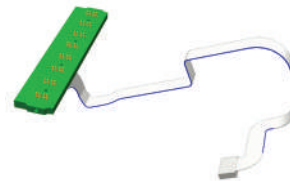

Type of part:  
Kit

Machine type:  
Magazine

Requirements:  
Agilis LM1216 magazine

Part no.	Product name
L-014-1551	Agilis interconnection board kit - QM16FIB



### Agilis interconnection board kit - QMFIB



**Type of part:**  
Kit

**Part is replacing:**  
L-014-1334

**Machine type:**  
Magazine

**Requirements:**  
Agilis L8 or LM8 magazine

Part no.	Product name
L-014-1334B	Agilis interconnection board kit - QMFIB

### Agilis Motor Unit



**Type of part:**  
Kit

**Description**  
Complete feeder motor unit with belt, belt pulley, magazine motor and QMMS-board.

**Machine type:**  
Magazine

Part no.	Product name
L-014-1329	Agilis Motor Unit

### Agilis Interface Parts



**Type of part:**  
Kit

**Description**  
Parts for positioning the magazine in a magazine slot.

**Machine type:**  
Magazine

Part no.	Product name
L-014-1327	Agilis Interface Parts

### Agilis Rear Handle Unit



**Type of part:**  
Kit

**Machine type:**  
Magazine

Part no.	Product name
L-014-1330	Agilis Rear Handle Unit

### Agilis Locking Unit



**Type of part:**  
Kit

**Description**  
Complete with 16 feeder hold down springs.

**Machine type:**  
Magazine

Part no.	Product name
L-014-1332	Agilis Locking Unit

### Agilis Safety Clamp



**Type of part:**  
Kit

**Machine type:**  
Magazine

Part no.	Product name
L-014-1337	Agilis Safety Clamp

### Agilis Solenoid Unit

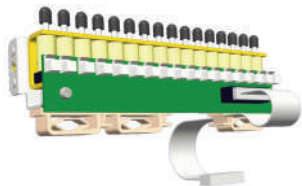

Type of part:  
Kit

**Description**

Complete with 16 solenoids and connection board for reel select solenoids.

**Machine type:**

Magazine

Part no.	Product name
L-014-1333	Agilis Solenoid Unit

**Machine type:**

Magazine

Part no.	Product name
L-014-1336	Agilis Y-adjustment Unit

### Drive unit

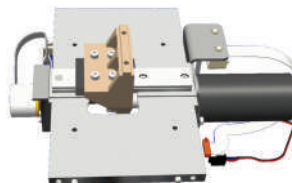

Type of part:  
Kit

**Machine type:**

Magazine

**Requirements:**

Agilis LM8 or LM1216 magazine

Part no.	Product name
L-014-1548	Drive unit

### Agilis Waste Shelf



Type of part:  
Kit

**Description**

Guide that prevents component waste tape entering the magazine slots.

**Machine type:**

Magazine

Part no.	Product name
L-014-1339	Agilis Waste Shelf

### Feeder head kit - ALM1216



Type of part:  
Kit

**Description**

Kit with 8 pcs of feeder heads and springs

**Machine type:**

Magazine

**Requirements:**

Agilis LM1216 magazine

Part no.	Product name
L-014-1523	Feeder head kit - ALM1216

### Agilis Y-adjustment Unit

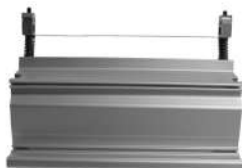

Type of part:  
Kit



### Feeder head kit - ALM8



**Type of part:**  
Kit

**Description**

Kit with 16 pcs of feeder heads and springs

**Machine type:**

Magazine

**Requirements:**

Agilis LM8 magazine

Part no.	Product name
L-014-1513	Feeder head kit - ALM8

Part no.	Product name
L-014-1545	Feeder head unit - ALM8

### MCU spare part kit



**Type of part:**  
Kit

**Machine type:**

TP9-2 , TP9-4 , TP11 , MY9 , MY12 , MY15 , MY19

Part no.	Product name
L-049-0565	MCU spare part kit

### Feeder head unit - ALM1216



**Type of part:**  
Kit

**Machine type:**

Magazine

**Requirements:**

Agilis LM1216 magazine

Part no.	Product name
L-014-1546	Feeder head unit - ALM1216

### Safety clamp - ALM1216



**Type of part:**  
Kit

**Machine type:**

Magazine

**Requirements:**

Agilis LM1216 Magazine

Part no.	Product name
L-014-1544	Safety clamp - ALM1216

### Feeder head unit - ALM8



**Type of part:**  
Kit

**Machine type:**

Magazine

**Requirements:**

Agilis LM8 magazine

### Safety clamp - ALM8



**Type of part:**  
Kit

**Machine type:**

Magazine

**Requirements:**

Agilis LM8 magazine

Part no.	Product name
L-014-1534	Safety clamp - ALM8

### Solenoid unit

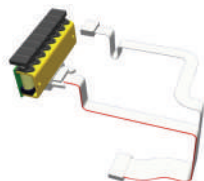

Type of part:  
Kit

Machine type:  
Magazine

Requirements:  
Agilis LM8 or LM1216 magazine

Part no.	Product name
L-014-1567	Solenoid unit

### Requirements:

Tray Exchanger with Serial number below 195.

Part no.	Product name
L-024-0180	Upgrade kit barcode reader

### Axle reel holder



Type of part:  
Mechanical component

Machine type:  
Magazine

Part no.	Product name
D-014-1077-4	Axle reel holder

### Tape support - ALM8



Type of part:  
Kit

Machine type:  
Magazine

Requirements:  
Agilis LM8 magazine

Part no.	Product name
L-014-1547	Tape support - ALM8

### Axle spindle uncover wheel arm

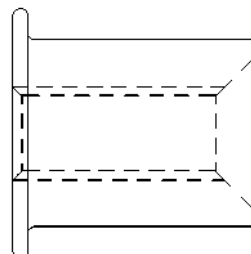

Type of part:  
Mechanical component

Machine type:  
Magazine

Part no.	Product name
D-014-0961-4	Axle spindle uncover wheel arm

### Upgrade kit barcode reader



Type of part:  
Kit

Description  
Upgrade kit to laser barcode reader for Tray Exchanger.

Machine type:  
Tray Exchanger

### Bracket, module Flex feeder



Type of part:  
Mechanical component

Description  
Holder for Flex feeder. Two required for each feeder.

**Machine type:**  
Magazine

**Requirements:**  
Flex magazine

Part no.	Product name
D-014-0769-4	Bracket, module Flex feeder

### Cover tape ruler, long



**Type of part:**  
Mechanical component

**Machine type:**  
Magazine

**Requirements:**  
Flex feeder 32-136 - L-014-1500

Part no.	Product name
D-014-1826	Cover tape ruler, long

### Cover tape ruler, short



**Type of part:**  
Mechanical component

**Machine type:**  
Magazine

**Requirements:**  
Flex feeder 32-136 - L-014-1500

Part no.	Product name
D-014-1827	Cover tape ruler, short

### Cover tube



**Type of part:**  
Mechanical component

#### Description

Prevents component tape to getting jammed on the internal wall in the tape reel container.

**Machine type:**  
Magazine

Part no.	Product name
D-014-0915-4	Cover tube

### Feeder number bar TM5632D



**Type of part:**  
Mechanical component

**Machine type:**  
Magazine

Part no.	Product name
L-014-0504	Feeder number bar TM5632D

### Feeder wheel



**Type of part:**  
Mechanical component

**Machine type:**  
Magazine

**Requirements:**  
Flex feeder 32-136 - L-014-1500

Part no.	Product name
D-014-1813	Feeder wheel

### Flexible joint 3/4



**Type of part:**  
Mechanical component

**Machine type:**  
Tray Elevator

**Requirements:**  
TPSys

Part no.	Product name
K-024-0012	Flexible joint 3/4

### Guide pin



**Type of part:**  
Mechanical component

**Description**  
Magazine guide pin in magazine slot.

**Machine type:**  
TP9-1 , TP9-2 , TP9-3 , TP9-4 , TP11 , TP12 , TP18

Part no.	Product name
D-011-0048-4	Guide pin

### Holder spring



**Type of part:**  
Mechanical component

**Description**  
Holder for component sticks on VMF30 magazines.

**Machine type:**  
Magazine

Part no.	Product name
D-014-0482-4	Holder spring

### Hub



**Type of part:**  
Mechanical component

**Machine type:**  
Magazine

**Requirements:**  
Flex feeder 32-136 - L-014-1500

Part no.	Product name
D-014-1812	Hub

### Hub for TM8 uncover roller



**Type of part:**  
Mechanical component

**Description**  
Hub for uncover wheels.

**Machine type:**  
Magazine

Part no.	Product name
D-014-0507B-4	Hub for TM8 uncover roller

### Loading spring



**Type of part:**  
Mechanical component

**Description**  
Loading spring on Tape Magazines.

**Machine type:**  
Magazine

Part no.	Product name
D-014-0659-4	Loading spring

### Magazine container bar



**Type of part:**  
Mechanical component

**Machine type:**  
Magazine

Part no.	Product name
D-014-0675-4	Magazine container bar

### Magazine guide right/left



**Type of part:**  
Mechanical component

**Description**  
Magazine slot guide rail.

**Machine type:**  
TP11 , TP12 , TP18 , TP9-1 , TP9-2 , TP9-3 , TP9-4

Part no.	Product name
D-011-0025-3	Magazine guide right/left

### Outflow spring

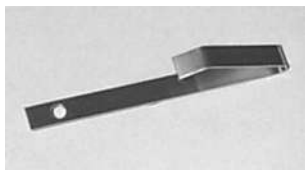

**Type of part:**  
Mechanical component

**Machine type:**  
Magazine

Part no.	Product name
D-014-0698-4	Outflow spring

### Position guide - male



**Type of part:**  
Mechanical component

**Machine type:**  
TP11 , TP12 , TP18 , TP9-1 , TP9-2 , TP9-3 , TP9-4

Part no.	Product name
D-011-0140-4	Position guide - male

### Shaft lower Flex magazine



**Type of part:**  
Mechanical component

**Machine type:**  
Magazine

Part no.	Product name
D-014-0774-3	Shaft lower Flex magazine

### Slide shoe



**Type of part:**  
Mechanical component

**Part is replacing:**  
D-014-0026-4

**Description**

Slide shoe for feeder arms in TM- magazine.

**Machine type:**

Magazine

Part no.	Product name
D-014-0026B-4	Slide shoe

**Sliding list bottom plate**



**Type of part:**  
Mechanical component

**Description**

Plastic strip on the feeder unit on Tape Magazine.

**Machine type:**

Magazine

Part no.	Product name
D-014-0683-4	Sliding list bottom plate

**Sliding list, container**



**Type of part:**  
Mechanical component

**Description**

Plastic strip on the tape reel container on Tape Magazine.

**Machine type:**

Magazine

Part no.	Product name
D-014-0666-3	Sliding list, container

**Spring Clip, TEX Cassette**



**Type of part:**  
Mechanical component

**Machine type:**

Tray Exchanger

Part no.	Product name
K-024-0037	Spring Clip, TEX Cassette

**Support spring Flex**

**Type of part:**  
Mechanical component

**Machine type:**

Magazine

**Requirements:**  
Only for 32 - 56 mm Flex feeders.

Part no.	Product name
D-014-1132-4	Support spring Flex

**Tape guide TM5632D**

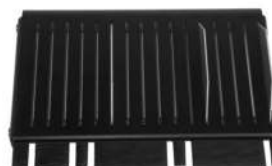

**Type of part:**  
Mechanical component

**Machine type:**

Magazine

Part no.	Product name
L-014-0502	Tape guide TM5632D



### Uncover wheel arm TM32D



**Type of part:**  
Mechanical component

**Machine type:**  
Magazine

Part no.	Product name
L-014-0279	Uncover wheel arm TM32D

### Air spring, hood



**Type of part:**  
Miscellaneous

**Description**  
Aditech 9 032 06.

**Machine type:**  
TP11 , TP9-4

Part no.	Product name
K-011-0027	Air spring, hood

### Lock ring LRA



**Type of part:**  
Miscellaneous

**Description**  
Plastic lock ring for Large Reel Attachment - L-014-0710B.

**Machine type:**  
Magazine

Part no.	Product name
M-0001	Lock ring LRA

### Magazine ref.point sticker 1\*5

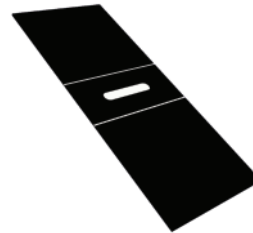

**Type of part:**  
Miscellaneous

**Description**  
To have the automatic magazine trim function working, magazines have to be equipped with this ref. point sticker.

**Machine type:**  
Magazine

**Requirements:**  
TPSys 1.5 or later

Part no.	Product name
D-014-0819-4	Magazine ref.point sticker 1*5

### Magnetic strip



**Type of part:**  
Miscellaneous

**Description**  
For Tray Wagon Magazine and Tray Elevator.

**Machine type:**  
Magazine , Tray Elevator

**Ordering info:**  
Sold per meter.

Part no.	Product name
K-025-0018	Magnetic strip

### Oldham coupling

**Type of part:**  
Miscellaneous

**Description**  
Oldham coupling for Agilis LM motor unit.

**Machine type:**  
Magazine

Part no.	Product name
L-014-1565	Oldham coupling

### Reflex tape



Type of part:  
Miscellaneous

#### Description

0.10 m used on each Tray Elevator.

#### Machine type:

Tray Elevator

#### Ordering info:

Sold per meter.

Part no.	Product name
K-024-0009	Reflex tape

### Motor

#### Type of part:

Motor

#### Description

Motor for Agilis LM.

#### Machine type:

Magazine

Part no.	Product name
L-014-1571	Motor

### GFIB edition 1, Generic Feeder Interface Board

#### Type of part:

PCB

#### Machine type:

TP9-1 , TP9-2 , TP9-3 , TP9-4 , TP11 , TP12 , TP18 , MY9 , MY12 , MY15 , MY19

#### Requirements:

Generic Feeder Interface

Part no.	Product name
L-019-1109-1	GFIB edition 1, Generic Feeder Interface Board

### MIBB Magazine Interface Bus Board



Type of part:  
PCB

#### Machine type:

MY9 , MY12 , MY15 , MY19

Part no.	Product name
L-049-0001-2	MIBB Magazine Interface Bus Board

### VC board for GFI

#### Type of part:

PCB

#### Machine type:

TP9-1 , TP9-2 , TP9-3 , TP9-4 , TP11 , TP12 , TP18 , MY9 , MY12 , MY15 , MY19

#### Requirements:

Generic Feeder Interface

Part no.	Product name
L-019-1110	VC board for GFI

### VC edition 4B, Vibration Control

#### Type of part:

PCB

#### Part is replacing:

L-019-0039-2

#### Description

Controller board in VMF30 magazine.

#### Machine type:

Magazine

Part no.	Product name
L-019-0039-4B	VC edition 4B, Vibration Control

## Encoder

**Type of part:**  
Unit

**Description**  
Encoder for Agilis LM

**Machine type:**  
Magazine

Part no.	Product name
L-014-1566	Encoder

## Feeder spring console complete

**Type of part:**  
Unit

**Part is replacing:**  
L-014-0275

**Description**  
For TM32D magazine

**Machine type:**  
Magazine

Part no.	Product name
L-014-0275D	Feeder spring console complete

## Hold-down spring complete



**Type of part:**  
Unit

**Description**  
Locking device for tape holder arms.

**Machine type:**  
Magazine

Part no.	Product name
L-014-0115	Hold-down spring complete

## Rear handle, ALM1216

**Type of part:**  
Unit

**Description**  
Rear panel with handle for Agilis LM1216.

**Machine type:**  
Magazine

Part no.	Product name
L-014-1574	Rear handle, ALM1216

## Rear handle, ALM8

**Type of part:**  
Unit

**Description**  
Rear panel with handle for Agilis LM8.

**Machine type:**  
Magazine

Part no.	Product name
L-014-1573	Rear handle, ALM8

## Rear unit

**Type of part:**  
Unit

**Description**  
Rear unit for Agilis LM.

**Machine type:**  
Magazine

Part no.	Product name
L-014-1603	Rear unit

## Uncover roller coverage



**Type of part:**  
Unit

**Machine type:**

Magazine

<b>Part no.</b>	<b>Product name</b>
L-014-0103	Uncover roller coverage

### Waste shelf

**Type of part:**

Unit

**Description**

For Agilis LM.

**Machine type:**

Magazine

<b>Part no.</b>	<b>Product name</b>
L-014-1621	Waste shelf



### Safety Button



**Type of part:**  
Electrical component

**Part is replacing:**  
E-011-0025

**Machine type:**

TP9-1, TP9-2, TP9-3, TP9-4, TP11, TP12, TP18, MY9, MY12, MY15, MY19

**Requirements:**

If replacing E-011-0025 you also need one of each: E-011-0011 Safety switch plate, E-011-0012 Safety switch contact block, E-011-0013 Safety switch contact block.

Part no.	Product name
E-011-0026	Safety Button

### Safety switch contact block



**Type of part:**  
Electrical component

**Description**

Used together with E-011-0010, E-011-0011 and E-011-0012.

Two used on each safety switch on TP9-1, TP9-2, TP9-3, TP9-4 and TP11.

One used on each safety switch on TP12 and TP18.

**Machine type:**

MY12, MY15, MY19, MY9, TP11, TP12, TP18, TP9-1, TP9-2, TP9-3, TP9-4

Part no.	Product name
E-011-0013	Safety switch contact block

### Safety switch contact block



**Type of part:**  
Electrical component

**Description**

Used together with E-011-0010, E-011-0011 and E-011-0013.

Two on each safety switch for TP9-4 and TP11.

One on each safety switch for TP12 and TP18.

One to three on safety switch for TP9-1 and TP9-2.

Three used on safety switch for TP9-3.

**Machine type:**

MY12, MY15, MY19, MY9, TP11, TP12, TP18, TP9-1, TP9-2, TP9-3, TP9-4

Part no.	Product name
E-011-0012	Safety switch contact block

### Safety switch plate



**Type of part:**  
Electrical component

**Description**

Used together with E-011-0010, E-011-0012.

Two on each safety switch on TP9-4 and TP11.

One on each safety switch on TP9-1, TP9-2, TP9-3, TP12 and TP18.

**Machine type:**

TP9-1, TP9-2, TP9-3, TP9-4, TP11, TP12, TP18

Part no.	Product name
E-011-0011	Safety switch plate

### Fan 120x120 24V 5W



**Type of part:**  
Electrical component

**Description**  
PAPST 4314.  
For framework on TP9-4 and TP11.  
For X-belt motor on MY-series, TP9-4 and TP11 machines.

**Machine type:**  
MY12 , MY15 , MY19 , MY9 , TP11 , TP9-4

Part no.	Product name
E-992-0005	Fan 120x120 24V 5W

**Description**  
Papst Multifan 8414.  
For framework on TP9-2, TP9-3, TP12 and TP18.  
For all AT-CPU2s.  
For X-belt motor on TP12 and TP18.

**Machine type:**  
TP9-2 , TP9-3 , TP12 , TP18

Part no.	Product name
K-021-0003	Fan 80x80x32

### Main Switch 3-pole



**Type of part:**  
Electrical component

**Part is replacing:**  
E-011-0030

**Description**  
Main power switch.

**Machine type:**  
MY12 , MY15 , MY19 , MY9 , TP11 , TP12 , TP18 , TP9-2 , TP9-4

Part no.	Product name
E-011-0049	Main Switch 3-pole

### Fan 172x150x38 330 m3/h 110V



**Type of part:**  
Electrical component

**Description**  
For Computer Box.

**Machine type:**  
MY12 , MY15 , MY19 , MY9

Part no.	Product name
E-992-0011	Fan 172x150x38 330 m3/h 110V

### Safety switch



**Type of part:**  
Electrical component

**Description**  
Large red safety switch button on TP machines.

**Machine type:**  
TP9-1 , TP9-2 , TP9-3 , TP9-4 , TP11 , TP12 , TP18

Part no.	Product name
E-011-0010	Safety switch

### Fan 80x80x32



**Type of part:**  
Electrical component

### Safety switch extension clip



**Type of part:**  
Electrical component

**Machine type:**

TP9-1 , TP9-2 , TP9-3 , TP9-4 , TP11 , TP12 , TP18

Part no.	Product name
E-011-0014	Safety switch extension clip

### SKB4-box cable



**Type of part:**  
Cable

**Description**

Cable from Computer Box to SKB4 board.

**Machine type:**

TP12 , TP18

Part no.	Product name
L-029-0006	SKB4-box cable

### Inspection window



**Description**

Glass cover for X movement.

Part no.	Product name
D-011-0034-4	Inspection window
D-011-0039-4	Inspection window, middle TP11

### SKB4-SKB4 cable



**Type of part:**  
Cable

**Description**

Cable between both SKB4 boards.

**Machine type:**

TP12 , TP18

Part no.	Product name
L-029-0007	SKB4-SKB4 cable

### Inspection window TP12/18

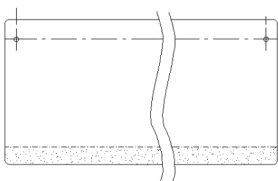

**Description**

Glass cover for X movement.

Part no.	Product name
D-021-0074-4	Inspection window, outer
D-021-0072-4	Inspection window, inner TP12
D-021-0073-4	Inspection window, inner TP18

### XMF1 glue cable 1

**Type of part:**

Cable

**Machine type:**

MY12 , MY15 , MY19 , MY9

Part no.	Product name
L-049-0016	XMF1 glue cable 1



## X/Y emergency cables



**Type of part:**  
Cable

**Machine type:**  
TP9-1 , TP9-2 , TP9-3

Part no.	Product name
L-019-0182C	X/Y emergency cables

## LCD monitor balance kit

**Type of part:**  
Kit

**Machine type:**  
MY9 , MY12 , MY15 , MY19

Part no.	Product name
L-040-1082	LCD monitor balance kit

## Bracket vertically adjustable



**Type of part:**  
Mechanical component

**Description**

The bracket makes it possible to remove the front cover on a MY series machine without disconnecting the TEX if one is used. The new bracket can be lowered to allow the cover to be hooked of the bracket.

Two pieces needed for each machine.

**Machine type:**  
MY12 , MY15 , MY19 , MY9

**Requirements:**  
Tray Exchanger.

Part no.	Product name
L-041-0410	Bracket vertically adjustable

## Component reject bin



**Type of part:**  
Miscellaneous

**Machine type:**  
MY12 , MY15 , MY19 , MY9

Part no.	Product name
K-041-0017	Component reject bin

## Fan 119x119x38 160 m3/h 110V



**Type of part:**  
Miscellaneous

**Description**

For cooling Computer Box and Booster.

**Machine type:**  
MY12 , MY15 , MY19 , MY9

Part no.	Product name
E-992-0010	Fan 119x119x38 160 m3/h 110V

## Filter cloth

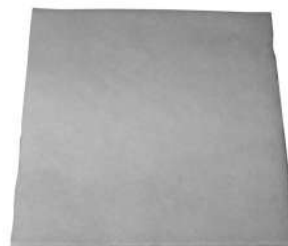

**Type of part:**  
Miscellaneous

**Description**

Filter cloth needs to be cut down to correct size to fit the fan.

**Machine type:**  
TP11 , TP9-4

Part no.	Product name
K-021-0025	Filter cloth

### Filter fan ZFF250/115VAC

**Type of part:**  
Miscellaneous

**Machine type:**  
MY9 , MY12 , MY15 , MY19

Part no.	Product name
K-011-0052B	Filter fan ZFF250/115VAC

### Filter ZFF 250



**Type of part:**  
Miscellaneous

**Description**  
Filter for large fan in framework.

**Machine type:**  
MY12 , MY15 , MY19 , MY9 , TP11 , TP9-2 , TP9-4

**Requirements:**  
Filter fan ZFF 250 or ZFF 255.

Part no.	Product name
K-011-0051	Filter ZFF 250

### Joystick with cable

**Type of part:**  
Miscellaneous

**Part is replacing:**  
L-019-0083B

**Machine type:**  
TP9-1 , TP9-2 , TP9-3 , TP9-4 , TP11 , TP12 , TP18 , MY9 , MY12 , MY15 , MY19

Part no.	Product name
L-019-0083C	Joystick with cable

### Lock with key



**Type of part:**  
Miscellaneous

**Machine type:**  
TP11 , TP12 , TP18 , TP9-1 , TP9-2 , TP9-3 , TP9-4

Part no.	Product name
K-021-0019	Lock with key

### Shock absorber Weforma



**Type of part:**  
Miscellaneous

**Part is replacing:**  
K-013-0027

**Description**  
X-wagon end stop shock absorber

**Machine type:**  
MY12 , MY15 , MY19 , MY9 , TP11 , TP9-4

Part no.	Product name
K-043-0007	Shock absorber Weforma

### Tempered glass 12X

**Type of part:**  
Miscellaneous

**Machine type:**  
MY12

Part no.	Product name
D-041-0323	Tempered glass 12X

## Tempered glass 3X

**Type of part:**  
Miscellaneous

**Machine type:**  
MY15

Part no.	Product name
D-041-0280	Tempered glass 3X

## Tempered glass 5X

**Type of part:**  
Miscellaneous

**Machine type:**  
MY19

Part no.	Product name
D-041-0141	Tempered glass 5X

## Tempered glass 9X

**Type of part:**  
Miscellaneous

**Machine type:**  
MY15 , MY19 , MY9

Part no.	Product name
D-041-0142	Tempered glass 9X

## Fan connection board

**Type of part:**  
PCB

**Machine type:**  
MY9 , MY12 , MY15 , MY19

Part no.	Product name
L-041-0084	Fan connection board

## SKB3 keyboard board



**Type of part:**  
PCB

**Description**  
Complete SKB3 excluding keytops.

**Machine type:**  
TP9-1 , TP9-2 , TP9-3 , TP9-4 , TP11

Part no.	Product name
L-019-0045-2	SKB3 keyboard board

## SKB4 keyboard



**Type of part:**  
PCB

**Part is replacing:**  
L-029-0003

**Machine type:**  
MY12 , MY15 , MY19 , MY9 , TP12 , TP18

Part no.	Product name
L-029-0003-1B	SKB4 keyboard

## Safety switch ELF3 flat key with cables

**Type of part:**  
Unit

**Machine type:**  
MY9 , MY12 , MY15 , MY19

Part no.	Product name
L-049-0441	Safety switch ELF3 flat key with cables

**XMF glue cable**

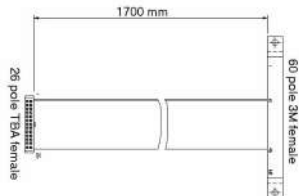

**Type of part:**  
Cable

**Description**

Cable from Computer Box to Glues Station slot.

**Machine type:**

TP9-2, TP9-3, TP9-4, TP11

Part no.	Product name
L-019-0412	XMF glue cable

**XMF glue cable**



**Type of part:**  
Cable

**Description**

Cable from Computer Box to Glue Station slot.

**Machine type:**

TP9-1

Part no.	Product name
L-019-0099	XMF glue cable

**XMF glue station adapter cable**

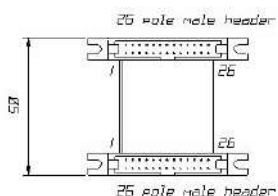

**Type of part:**  
Cable

**Machine type:**

TP9-1, TP9-2, TP9-3, TP9-4, TP11

Part no.	Product name
L-019-0631	XMF glue station adapter cable

**XMF2 glue station cable**

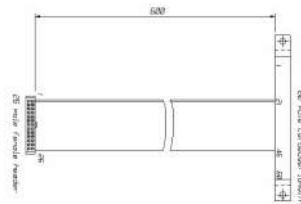

**Type of part:**  
Cable

**Machine type:**

TP9-1, TP9-2, TP9-3, TP9-4, TP11

Part no.	Product name
L-019-0632	XMF2 glue station cable

**Cogwheel 15 teeth, plastic**



**Type of part:**  
Cog wheel

**Description**

Small cogwheel for glue pot rotation mechanism.

**Machine type:**

Glue Station

Part no.	Product name
D-014-0708-4	Cogwheel 15 teeth, plastic

**Cogwheel 50 teeth, plastic**



**Type of part:**  
Cog wheel

**Description**

Large cogwheel for glue pot rotation mechanism.

**Machine type:**

Glue Station

Part no.	Product name
D-014-0707-4	Cogwheel 50 teeth, plastic

**Glue pot with leveling arm**



**Type of part:**  
Kit

**Machine type:**

Glue Station

Part no.	Product name
L-014-0701	Glue pot with leveling arm

**Cover glue station**

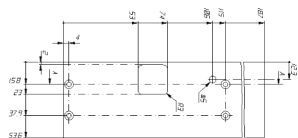

**Type of part:**  
Mechanical component

**Description**

Transparent plastic cover on the glue station.

**Machine type:**

Glue Station

Part no.	Product name
D-014-0723B-4	Cover glue station

**O-ring 3.1x1.6**



**Type of part:**  
Miscellaneous

**Machine type:**

Glue Station

Part no.	Product name
M-0944	O-ring 3.1x1.6

**Z motor with encoder**



**Type of part:**  
Motor

**Part is replacing:**  
L-019-0004

**Description**

Z-motor or glue pot rotation motor on Glue Station 2.

**Machine type:**

TP9-1 , TP9-2

**Requirements:**

XWB ed. 4 or later version.

Part no.	Product name
L-019-0004B	Z motor with encoder

### HYDRA 2D spare part

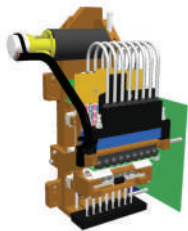

#### Description

HYDRA 2D compatible with machines with or without Automatic Tool Exchange. Note that HYDRA tools are not included in this HYDRA.

Part no.	Product name
L-012-0713	HYDRA 2D MY Spare Part
L-012-0711	HYDRA 2D MY Refurbished
L-012-0712	HYDRA 2D TP Refurbished

### HYDRA theta belt



#### Description

Steel-belt version

#### Requirements:

HYDRA 2D

Part no.	Product name
L-012-0291	HYDRA theta-belt spare part kit
L-012-0388	HYDRA mylar belt spare part kit

### Shims



Part no.	Product name
D-015-1554	SHIMS 1
D-015-1553	SHIMS 2
D-015-1552	SHIMS 3

### Spring for tool bank



Part no.	Product name
D-015-1409	Spring Tool Bank
D-015-1406	Spring Tool Bank PT

### XHYD HYDB-XWB3 cable

#### Type of part:

Cable

#### Part is replacing:

L-019-0672B

#### Machine type:

HYDRA , MY12 , MY15 , MY19 , MY9 , TP11 , TP9-4

Part no.	Product name
L-049-0424B	XHYD HYDB-XWB3 cable

### Fan, HYDRA



#### Type of part:

Electrical component

#### Machine type:

MY12 , MY15 , MY19 , MY9 , TP11 , TP9-4

Part no.	Product name
L-019-0668	Fan, HYDRA

### NTC with cable

#### Type of part:

Electrical component

#### Machine type:

MY12 , MY15 , MY19 , MY9 , TP12 , TP9-4

#### Requirements:

Hydra 2D

Part no.	Product name
----------	--------------

L-049-0512	NTC with cable
------------	----------------

### Fastener kit HYDRA 2D

**Type of part:**  
Kit

**Description**

Shims, washers and screws for mounting HYDRA 2D on machine.

**Machine type:**

MY12 , MY15 , MY19 , MY9 , TP11 , TP9-4

Part no.	Product name
----------	--------------

L-012-0614	Fastener kit HYDRA 2D
------------	-----------------------

### HYDRA 2B ATE upgrade kit

**Type of part:**  
Kit

**Description**

Kit for upgrading a HYDRA 2B unit to be compatible with Automatic Tool Exchange.

**Machine type:**

TP9-4 , TP11 , MY9 , MY12 , MY15 , MY19

**Requirements:**

HYDRA 2B

Part no.	Product name
----------	--------------

L-015-1577	HYDRA 2B ATE upgrade kit
------------	--------------------------

### HYDRA 2D Maintenance kit

**Type of part:**  
Kit

**Description**

Standard maintenance kit delivered with all machines with HYDRA.

- 1 x Set of 8 Tools H01 (L-012-0533B)
- 1 x Set of 8 Tools H02 (L-012-0534B)
- 1 x Set of 8 Tools H03 (L-012-0535B)
- 1 x O-ring package (L-012-0553B)
- 1 x Grease tube 25g (K-012-0122B)
- 2 x Spring Tool Bank (D-015-1409)
- 2 x Spring Tool Bank PT (D-015-1406)
- 1 x O-ring moulder tool complete (L-012-0578)
- 8 x Filter (K-012-0141)
- 1 x HYDRA Theta-belt (L-012-0291)

**Machine type:**

MY12 , MY15 , MY19 , MY9 , TP11 , TP9-4

Part no.	Product name
----------	--------------

L-015-1658	HYDRA 2D Maintenance kit
------------	--------------------------

### HYDRA ATE Maintenance kit

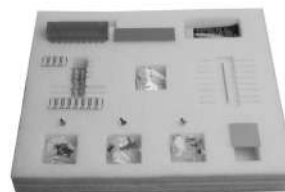

**Type of part:**  
Kit

**Description**

Maintenance kit for machines with Automatic Tool Exchange.

**Machine type:**

MY12 , MY15 , MY19 , MY9 , TP11 , TP9-4

Part no.	Product name
----------	--------------

L-015-1576	HYDRA ATE Maintenance kit
------------	---------------------------

### Latch washer set of 10

**Type of part:**  
Kit

**Description**

Washers for adjusting latches on HYDRA 2D.

**Machine type:**

TP9-4 , TP11 , MY9 , MY12 , MY15 , MY19

**Requirements:**

HYDRA 2D

Part no.	Product name
----------	--------------

L-012-0858	Latch washer set of 10
------------	------------------------

### O-ring package

**Type of part:**  
Kit

**Description**

Package of 50 o-rings for HYDRA tool tubes.

**Machine type:**

MY12 , MY15 , MY19 , MY9 , TP11 , TP9-4

Part no.	Product name
L-012-0553B	O-ring package

**Stops, spare part kit**



Type of part:  
Kit

Machine type:  
MY12 , MY15 , MY19 , MY9 , TP11 , TP9-4

Part no.	Product name
L-012-0522	Stops, spare part kit

**Tool Tip HYDRA, 10-pcs**



Type of part:  
Kit

Machine type:  
MY12 , MY15 , MY19 , MY9 , TP11 , TP9-4

Part no.	Product name
L-012-0378	Tool Tip HYDRA, 10-pcs

**Tool, Exchangeable, set of 8**



Type of part:  
Kit

Machine type:  
MY12 , MY15 , MY19 , MY9 , TP11 , TP9-4

Requirements:  
HYDRA 2B

Part no.	Product name
L-012-0512	Tool, Exchangeable, set of 8

**HYDRA Tool**



Type of part:  
Mechanical component

Machine type:  
MY12 , MY15 , MY19 , MY9 , TP11 , TP9-4

Requirements:  
HYDRA 2 edition 1 and 1B.

Part no.	Product name
L-012-0433	HYDRA Tool

**HYDRA Tool D=2.6**

Type of part:  
Mechanical component

Part is replacing:  
L-012-0353

Machine type:  
TP9-4 , TP11

Requirements:  
HYDRA edition 1 or 1B.

Part no.	Product name
L-012-0364	HYDRA Tool D=2.6

**Reference points complete type 14**



Type of part:  
Mechanical component

Part is replacing:  
L-012-0509

Machine type:  
MY12 , MY15 , MY19 , MY9 , TP11 , TP9-4



Part no.	Product name
L-012-0509B	Reference points complete type 14

### Grease tube 25g



**Type of part:**  
Miscellaneous

**Part is replacing:**  
K-012-0122

#### Description

Grease Paraliq GA 351

#### Machine type:

MY12, MY15, MY19, MY9, TP11, TP9-4

Part no.	Product name
K-012-0122B	Grease tube 25g

### Illumination cover



**Type of part:**  
Miscellaneous

#### Description

Plexiglass cover over illumination board on HYDRA camera.

#### Machine type:

MY12, MY15, MY19, MY9, TP11, TP9-4

Part no.	Product name
D-015-0675-3	Illumination cover

### Oiler, HYDRA



**Type of part:**  
Miscellaneous

#### Machine type:

MY12, MY15, MY19, MY9, TP11, TP9-4

Part no.	Product name
K-012-0109	Oiler, HYDRA

### Reflex protection Z Wagon



**Type of part:**  
Miscellaneous

#### Machine type:

MY12, MY15, MY19, MY9, TP11, TP9-4

Part no.	Product name
D-012-0898	Reflex protection Z Wagon

### Rubber cloth 40 x 40 x 1 mm

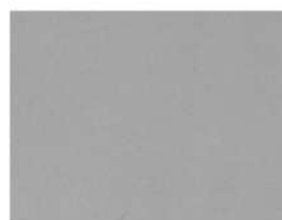

**Type of part:**  
Miscellaneous

#### Description

For removing Hydra tool tubes.

#### Machine type:

MY12, MY15, MY19, MY9, TP11, TP9-4

Part no.	Product name
K-012-0013	Rubber cloth 40 x 40 x 1 mm

### Tool H04 spare tips

#### Type of part:

Miscellaneous

#### Description

Set of 20 replacement rubber tips for H04 tools - L-012-0572.

The life of the rubber tips is very dependent upon the application. It's recommended to replace the rubber tips at any sign of wear or when the expiry date of the tools has been passed.

#### Machine type:

MY12, MY15, MY19, MY9, TP11, TP9-4

#### Requirements:

HYDRA

Part no.	Product name
L-012-0576	Tool H04 spare tips

### Vacuum filter HYDRA 100-pcs



**Type of part:**  
Miscellaneous

**Part is replacing:**  
K-012-0081

**Description**

Package of 100 pcs filters.

**Machine type:**

MY12 , MY15 , MY19 , MY9 , TP11 , TP9-4

**Requirements:**

HYDRA 2B and ealier versions of HYDRA.

Part no.	Product name
K-012-0108	Vacuum filter HYDRA 100-pcs

Part no.	Product name
L-012-0853	HZ-motor unit

### Theta motor unit



**Type of part:**  
Motor

**Part is replacing:**  
L-012-0440

**Machine type:**

MY12 , MY15 , MY19 , MY9 , TP11 , TP9-4

Part no.	Product name
L-012-0440B	Theta motor unit

### Vacuum filter pack



**Type of part:**  
Miscellaneous

**Description**

Package of 10 pcs filters (K-012-0141).

**Machine type:**

MY12 , MY15 , MY19 , MY9 , TP11 , TP9-4

**Requirements:**

HYDRA 2D

Part no.	Product name
L-012-0628	Vacuum filter pack

### Upgrade HZ motor Hydra



**Type of part:**  
Motor

**Part is replacing:**  
L-012-0435B

**Machine type:**

MY12 , MY15 , MY19 , MY9 , TP11 , TP9-4

Part no.	Product name
L-012-0809	Upgrade HZ motor Hydra

### HZ-motor unit

**Type of part:**

Motor

**Part is replacing:**

L-012-0808

**Machine type:**

TP9-4 , TP11 , MY9 , MY12 , MY15 , MY19

### HYDB2 HYDRA device board 2



**Type of part:**  
PCB

**Description**

This board controls everything on the HYDRA, but the motors. It connects to the XWB3, HYDVB, HYDSB and the HYDUFB2. It also connects to the HZ motor and the HZ encoder. The fan for the HZ motor and the relay, selecting current output for the Z or the HZ motor, are also controlled by this board, but the connector for the fan and the relay are both located on the XWB3 board.

**Machine type:**

TP9-4 , TP11 , MY9 , MY12 , MY15 , MY19

**Requirements:**

HYDRA edition 1B, HYDRA2

Part no.	Product name
L-019-0892-1	HYDB2 HYDRA device board 2

**HYDUBB HYDRA DUB board**



**Type of part:**  
PCB

**Description**

On this small board the LEDs for the ISIC, or HZ sensors, are located. It also contains the connectors for the HFi motor and HFi transducer. It connects to HYDUFB.

**Machine type:**

TP11 , TP9-4

**Requirements:**

HYDRA edition 1B, HYDRA2

Part no.	Product name
L-019-0634-2	HYDUBB HYDRA DUB board

**HYDUFB2 HYDRA DUF board 2**



**Type of part:**  
PCB

**Description**

The flex board with the HZ-sensors for the HYDRA.

**Machine type:**

MY12 , MY15 , MY19 , MY9 , TP11 , TP9-4

**Requirements:**

HYDRA edition 1B, HYDRA2

Part no.	Product name
L-019-0893-2	HYDUFB2 HYDRA DUF board 2

**Plate Assistant**



**Type of part:**  
Special MYDATA tool

**Machine type:**

MY12 , MY15 , MY19 , MY9 , TP11 , TP9-4

Part no.	Product name
D-015-1738	Plate Assistant

**HYDRA Camera box**



**Type of part:**  
Unit

**Part is replacing:**

L-015-0335

**Machine type:**

MY12 , MY15 , MY19 , MY9 , TP11 , TP9-4

**Requirements:**

HYDRA, HYDRA2.

Part no.	Product name
L-015-0431B	HYDRA Camera box

**Reference points complete type 23**

**Type of part:**

Unit

**Description**

Reference points device for HYDRA ER

**Machine type:**

MY9 , MY12 , MY15 , MY19

**Requirements:**

HYDRA 2D

Part no.	Product name
L-012-0550	Reference points complete type 23

### Solenoid complete HYDRA



**Type of part:**  
Unit

**Part is replacing:**  
L-012-0351

**Machine type:**

MY12 , MY15 , MY19 , MY9 , TP11 , TP9-4

**Requirements:**

HYDRA 2B and HYDRA 2D.

Part no.	Product name
L-012-0436	Solenoid complete HYDRA

### Vacuum Unit



**Type of part:**  
Unit

**Part is replacing:**  
L-012-0442

**Machine type:**

MY12 , MY15 , MY19 , MY9 , TP11 , TP9-4

Part no.	Product name
L-012-0609	Vacuum Unit



**Cassette holder**



Part no.	Product name
K-017-0065	Cassette holder, lower
K-017-0066	Cassette holder, upper

**Magnetic valve**



**Description**  
Festo 7802.

Part no.	Product name
K-017-0060	Magnetic valve 3-1/8
K-017-0061	Magnetic valve 5/18

**Belt Transport/Buffer**



**Type of part:**  
Belt

**Description**  
10x940 mm

**Machine type:**  
Buffert Conveyor , Transport Conveyor

Part no.	Product name
K-017-0163	Belt Transport/Buffer

**Cassette transport belt**



**Type of part:**  
Belt

**Description**  
GG10N Siegling 945mm.

**Machine type:**  
Elevator

Part no.	Product name
K-017-0058	Cassette transport belt

**Cassette transport belt, lower**



**Type of part:**  
Belt

**Description**  
GG10N Siegling 1860mm.

**Machine type:**  
Loader , Unloader

Part no.	Product name
K-017-0056	Cassette transport belt, lower

**Cassette transport belt, upper**



**Type of part:**  
Belt

**Description**  
GG10N Siegling 1435mm.

**Machine type:**  
Loader , Unloader

Part no.	Product name
K-017-0057	Cassette transport belt, upper

### Drive belt Conveyor/Destacker

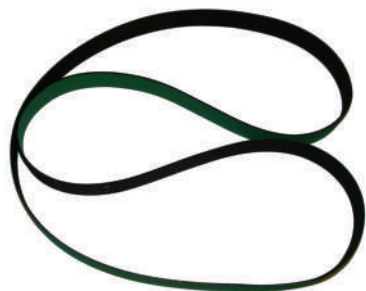

**Type of part:**  
Belt

**Machine type:**  
Transport Conveyor

Part no.	Product name
K-017-0275	Drive belt Conveyor/Destacker

### Transport belt diameter 4mm



**Type of part:**  
Belt

**Description**  
950002 SIEGLING.

**Machine type:**  
Buffert Conveyor , Transport Conveyor , Work Station

**Ordering info:**  
Sold per meter.

Part no.	Product name
K-017-0053	Transport belt diameter 4mm

### Transport Belt GT6 19\*1850



**Type of part:**  
Belt

**Description**  
Siegling GT6 19\*1850.

**Machine type:**  
Buffert Conveyor

**Requirements:**  
Buffer Conveyor BC1200, BC1500, BC2000 and BC2500.

Part no.	Product name
K-017-0093	Transport Belt GT6 19*1850

### Transport Belt GT6 19\*2050



**Type of part:**  
Belt

**Description**  
Siegling GT6 19\*2050.

**Machine type:**  
Transport Conveyor

**Requirements:**  
Transport Conveyor TC700.

Part no.	Product name
K-017-0088	Transport Belt GT6 19*2050

### Transport Belt GT6 19\*2200



**Type of part:**  
Belt

**Description**  
Siegling GT6 19\*2200.

**Machine type:**  
Loader , Unloader

Part no.	Product name
K-017-0097	Transport Belt GT6 19*2200

**Transport Belt GT6 19\*2450**



**Type of part:**  
Belt

**Description**  
Siegling GT6 19\*2450.

**Machine type:**  
Buffert Conveyor

**Requirements:**  
Buffer Conveyor BC1500.

Part no.	Product name
K-017-0094	Transport Belt GT6 19*2450

**Transport Belt GT6 19\*3050**



**Type of part:**  
Belt

**Description**  
Siegling GT6 19\*3050.

**Machine type:**  
Transport Conveyor

**Requirements:**  
Transport Conveyor TC1200.

Part no.	Product name
K-017-0089	Transport Belt GT6 19*3050

**Transport Belt GT6 19\*3450**



**Type of part:**  
Belt

**Description**  
Siegling GT6 19\*3450.

**Machine type:**  
Buffert Conveyor

**Requirements:**  
Buffer Conveyor BC2000.

Part no.	Product name
K-017-0095	Transport Belt GT6 19*3450

**Transport Belt GT6 19\*3650**



**Type of part:**  
Belt

**Description**  
Siegling GT6 19\*3650.

**Machine type:**  
Transport Conveyor

**Requirements:**  
Transport Conveyor TC1500.

Part no.	Product name
K-017-0090	Transport Belt GT6 19*3650

**Transport Belt GT6 19\*4450**



**Type of part:**  
Belt

**Description**  
Siegling GT6 19\*4450.



**Machine type:**  
Buffert Conveyor

**Requirements:**  
Buffer Conveyor BC2500.

Part no.	Product name
K-017-0096	Transport Belt GT6 19*4450

### Transport Belt GT6 19\*4650



**Type of part:**  
Belt

**Description**  
Siegling GT6 19\*4650.

**Machine type:**  
Transport Conveyor

**Requirements:**  
Transport Conveyor TC2000.

Part no.	Product name
K-017-0091	Transport Belt GT6 19*4650

### Transport Belt GT6 19\*5650



**Type of part:**  
Belt

**Description**  
Siegling GT6 19\*5650.

**Machine type:**  
Transport Conveyor

**Requirements:**  
Transport Conveyor TC2500.

Part no.	Product name
K-017-0092	Transport Belt GT6 19*5650

### Transport Belt TT5/1-HC 18\*2580

**Type of part:**  
Belt

**Description**  
Siegling TT5/1-HC 18\*2580.

**Machine type:**  
Loader , Unloader

Part no.	Product name
K-017-0098	Transport Belt TT5/1-HC 18*2580

### Amplifier for slot sensor



**Type of part:**  
Electrical component

**Description**  
F5N-PNP SEEKA.

**Machine type:**  
Elevator

Part no.	Product name
K-017-0068	Amplifier for slot sensor

### Endpoint switch for elevator



**Type of part:**  
Electrical component

**Description**  
SHL.W255 OMRON.

**Machine type:**  
Elevator

Part no.	Product name
K-017-0069	Endpoint switch for elevator

**In-line adapter sensor**



**Type of part:**  
Electrical component

**Machine type:**  
MY12 , MY15 , MY19 , MY9 , TP11 , TP12 , TP18 , TP9-1 , TP9-2 , TP9-3 , TP9-4

Part no.	Product name
L-017-0016	In-line adapter sensor

**Photo switch**



**Type of part:**  
Electrical component

**Machine type:**  
Buffert Conveyor , Transport Conveyor

Part no.	Product name
K-017-0165	Photo switch

**Photo switch**



**Type of part:**  
Electrical component

**Machine type:**  
Transport Conveyor

Part no.	Product name
K-017-0367	Photo switch

**PUB motor control 2405A**

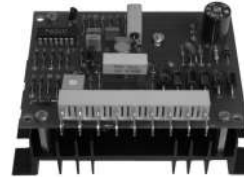

**Type of part:**  
Electrical component

**Description**  
2405A GME.

**Machine type:**  
Transport Conveyor , Work Station

**Requirements:**  
Model 1 Conveyor.

Part no.	Product name
K-017-0070	PUB motor control 2405A

**PUB motor control 2410A**

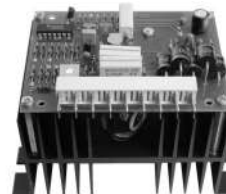

**Type of part:**  
Electrical component

**Description**  
2410A GME

**Machine type:**  
Loader , Transport Conveyor , Work Station

**Requirements:**  
Model 1 Conveyor

Part no.	Product name
K-017-0071	PUB motor control 2410A

**Relay**



**Type of part:**  
Electrical component

**Machine type:**  
Buffert Conveyor , Loader , Transport Conveyor , Unloader , Work Station

Part no.	Product name
K-017-0168	Relay

**Relay type 40.52**



**Type of part:**  
Electrical component

**Machine type:**  
Transport Conveyor

Part no.	Product name
K-017-0059	Relay type 40.52

**Relay type 55.34**



**Type of part:**  
Electrical component

**Machine type:**  
Transport Conveyor

Part no.	Product name
K-017-0051	Relay type 55.34

**Safety reflex sensor**



**Type of part:**  
Electrical component

**Description**  
31325 FESTO.

**Machine type:**  
Unloader

Part no.	Product name
K-017-0072	Safety reflex sensor

**Sensor WT150-P162**



**Type of part:**  
Electrical component

**Description**  
Sick WT150-P162.

**Machine type:**  
Buffert Conveyor , Loader , Transport Conveyor , Unloader , Work Station

Part no.	Product name
K-017-0087	Sensor WT150-P162

**Sensor WT170-P112**



**Type of part:**  
Electrical component

**Description**  
Sick WT170-P112.

**Machine type:**  
Buffert Conveyor , Transport Conveyor , Work Station

Part no.	Product name
K-017-0086	Sensor WT170-P112

**Slot sensor for index bar**



**Type of part:**  
Electrical component

**Description**  
FU 712.BC SEEKA.

**Machine type:**  
Elevator

Part no.	Product name
K-017-0067	Slot sensor for index bar

**Switch with light**

**Type of part:**  
Electrical component

**Machine type:**  
Buffert Conveyor , Transport Conveyor , Work Station

Part no.	Product name
K-017-0104	Switch with light

**Transformer**



**Type of part:**  
Electrical component

**Machine type:**  
Buffert Conveyor , Transport Conveyor , Work Station

Part no.	Product name
K-017-0169	Transformer

**Adjustable foot**



**Type of part:**  
Mechanical component

**Machine type:**  
Buffert Conveyor , Elevator , Transport Conveyor , Tray Elevator , Tray Exchanger , Unloader , Work Station

Part no.	Product name
K-017-0074	Adjustable foot

**Grooved nut M6 for Alu-profile**

**Type of part:**  
Mechanical component

**Machine type:**  
Buffert Conveyor , Transport Conveyor , Tray Elevator , Tray Exchanger , Unloader , Work Station

Part no.	Product name
K-017-0079	Grooved nut M6 for Alu-profile

### Grooved nut M8 for Alu-profile

**Type of part:**  
Mechanical component

**Machine type:**  
Buffert Conveyor , Transport Conveyor , Tray Elevator , Tray Exchanger , Unloader , Work Station

Part no.	Product name
K-017-0080	Grooved nut M8 for Alu-profile

### Pusher Loader



**Type of part:**  
Mechanical component

**Description**  
Festo 10401.

**Machine type:**  
Loader

Part no.	Product name
K-017-0062	Pusher Loader

### Pusher Unloader



**Type of part:**  
Mechanical component

**Description**  
Origa P210.

**Machine type:**  
Unloader

Part no.	Product name
K-017-0063B	Pusher Unloader

### Pusher Unloader



**Type of part:**  
Mechanical component

**Description**  
Festo 5045.

**Machine type:**  
Unloader

Part no.	Product name
K-017-0063	Pusher Unloader

### Reflector plate



**Type of part:**  
Mechanical component

**Description**  
SOE-RFS-20 Festo.

**Machine type:**  
Transport Conveyor

Part no.	Product name
K-017-0073	Reflector plate

### Cam follower



**Type of part:**  
Miscellaneous

**Machine type:**  
Buffert Conveyor , Loader , Transport Conveyor , Unloader , Work Station

Part no.	Product name
K-017-0166	Cam follower

### Cylinder in pusher

**Type of part:**  
Miscellaneous

**Description**  
Origa OSP-P10

**Machine type:**  
Unloader , Loader

**Requirements:**  
Loader / Unloader ED500 UL

Part no.	Product name
K-017-0224	Cylinder in pusher

### FXOS-14MT-DSS PLC,E53-PLC-10



**Type of part:**  
Miscellaneous

**Description**  
For 500 - 2000 mm long conveyors.

**Machine type:**  
Buffert Conveyor , Transport Conveyor

**Ordering info:**  
Please state type of conveyor, length and options on conveyor when ordering (auto width, board train).

Part no.	Product name
K-017-0180	FXOS-14MT-DSS PLC,E53-PLC-10

### FXOS-20MT-DSS PLC,E53-PLC-11

**Type of part:**  
Miscellaneous

**Description**  
For 2500 mm long conveyors

**Machine type:**  
Transport Conveyor , Work Station , Buffert Conveyor

**Ordering info:**  
Please state type of conveyor and options on conveyor when ordering (auto width, board train)

Part no.	Product name
K-017-0181	FXOS-20MT-DSS PLC,E53-PLC-11

### Motor controller, E51-U-5



**Type of part:**  
Miscellaneous

**Machine type:**  
Buffert Conveyor , Transport Conveyor

Part no.	Product name
K-017-0179	Motor controller, E51-U-5

### Rocker switch, E56-SW-2



**Type of part:**  
Miscellaneous

**Machine type:**  
Buffert Conveyor , Transport Conveyor

Part no.	Product name
K-017-0177	Rocker switch, E56-SW-2

### Selector switch, E56-SW-4.4



**Type of part:**  
Miscellaneous

**Machine type:**  
Buffert Conveyor , Transport Conveyor

Part no.	Product name
K-017-0178	Selector switch, E56-SW-4.4

**Requirements:**  
Model 1 Conveyor.

Part no.	Product name
K-017-0054	DC-motor 12V 40 rpm

### DC-motor 24V



**Type of part:**  
Motor

**Description**  
403290 SWF.

**Machine type:**  
Buffert Conveyor , Loader , Transport Conveyor , Work Station

**Requirements:**  
Model 1 Conveyor.

Part no.	Product name
K-017-0052	DC-motor 24V

### Signal interface



**Type of part:**  
Miscellaneous

**Machine type:**  
Buffert Conveyor , Loader , Transport Conveyor , Tray Elevator ,  
Tray Exchanger , Unloader , Work Station

Part no.	Product name
K-017-0167	Signal interface

### DC-motor 24V elevator



**Type of part:**  
Motor

**Description**  
402303 SWF.

**Machine type:**  
Elevator

Part no.	Product name
K-017-0055	DC-motor 24V elevator

### DC-motor 12V 40 rpm



**Type of part:**  
Motor

**Description**  
403288 SWF.

**Machine type:**  
Buffert Conveyor , Loader , Transport Conveyor , Work Station

### DC motor 12V 80RPM

**Type of part:**  
Motor

**Description**  
SWF 403.712.

**Machine type:**  
Loader , Unloader

Part no.	Product name
K-017-0109	DC motor 12V 80RPM

### DC motor 12V 80rpm for BC



**Type of part:**  
Motor

**Description**  
SWF 403289.

**Machine type:**  
Buffert Conveyor

Part no.	Product name
K-017-0064	DC motor 12V 80rpm for BC

### DC motor 24V 130RPM



**Type of part:**  
Motor

**Description**  
SWF 403.931.

**Machine type:**  
Buffert Conveyor , Transport Conveyor , Work Station

Part no.	Product name
K-017-0108	DC motor 24V 130RPM

### DC motor 24V 40RPM

**Type of part:**  
Motor

**Description**  
SWF 403.854.

**Machine type:**  
Loader , Unloader

Part no.	Product name
K-017-0110	DC motor 24V 40RPM

### DC motor 24V 80RPM



**Type of part:**  
Motor

**Description**  
SWF 403.931.

**Machine type:**  
Buffert Conveyor , Transport Conveyor , Work Station

Part no.	Product name
K-017-0111	DC motor 24V 80RPM

### Motor

**Type of part:**  
Motor

**Machine type:**  
Transport Conveyor

**Requirements:**  
De-stacker EP760

Part no.	Product name
K-017-0208	Motor

### Motor M22 width adjustment



**Type of part:**  
Motor

**Machine type:**  
Buffert Conveyor , Transport Conveyor , Work Station



Part no.	Product name
K-017-0176	Motor M22 width adjustment

### Motor (external conveyor)



Type of part:  
Motor

**Machine type:**  
Buffert Conveyor , Transport Conveyor

Part no.	Product name
K-017-0164	Motor (external conveyor)

### Stepper motor with brake



Type of part:  
Motor

**Description**  
4HS618C0408.

**Machine type:**  
Loader , Unloader

Part no.	Product name
K-017-0085	Stepper motor with brake

### Valve monst.

**Type of part:**  
Unit

**Machine type:**  
Transport Conveyor

**Requirements:**  
De-stacker EP760

Part no.	Product name
K-017-0219	Valve monst.

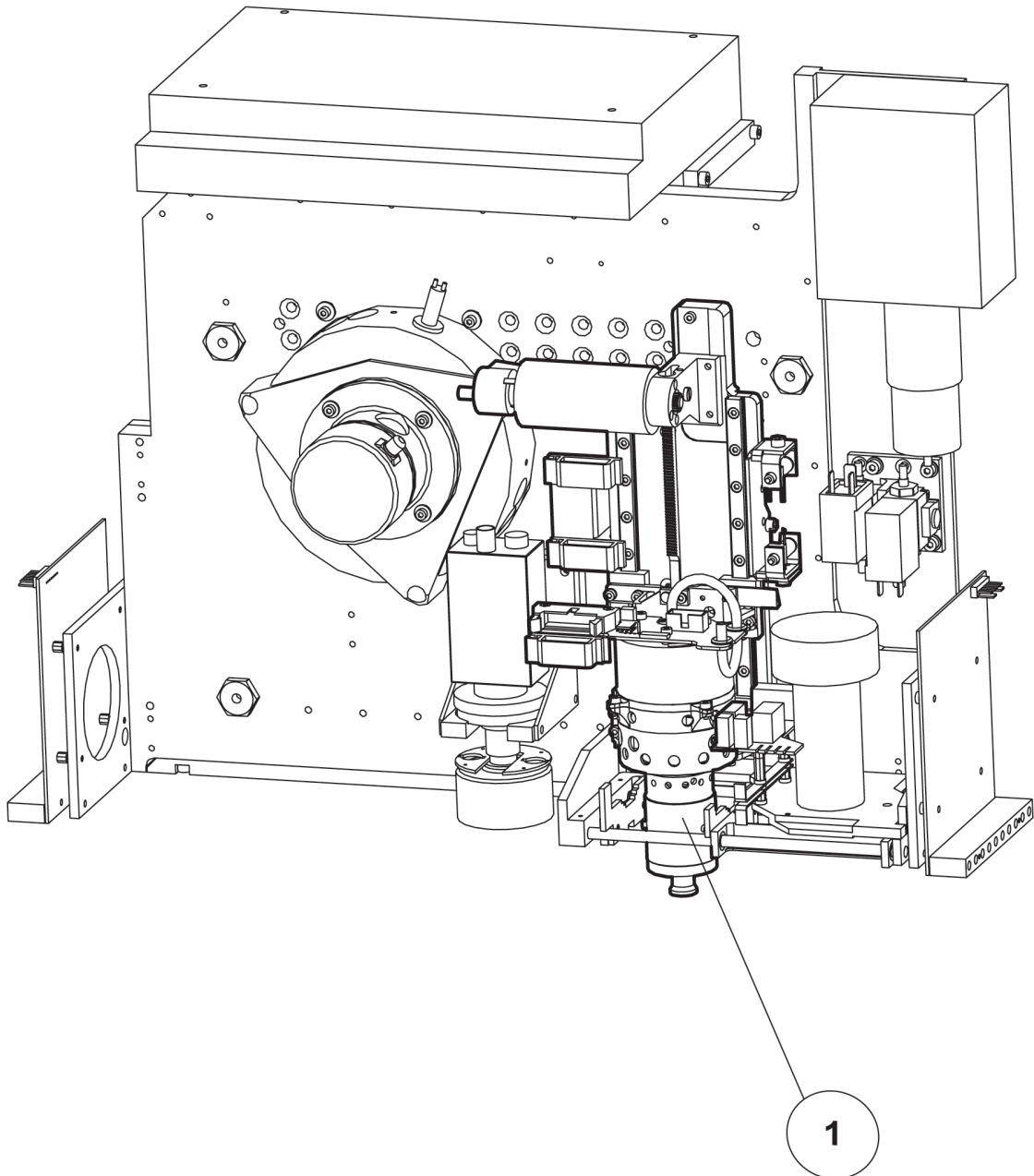

**Midas, spare part kit****Position:** 1**Type of part:**  
Kit**Description**

Midas unit with assembly components to be used when replacing Midas.

**Machine type:**

MY12 , MY15 , MY19 , MY9

**Requirements:**

MY-machine equipped with Midas.

<b>Part no.</b>	<b>Product name</b>
L-022-0110	Midas, spare part kit

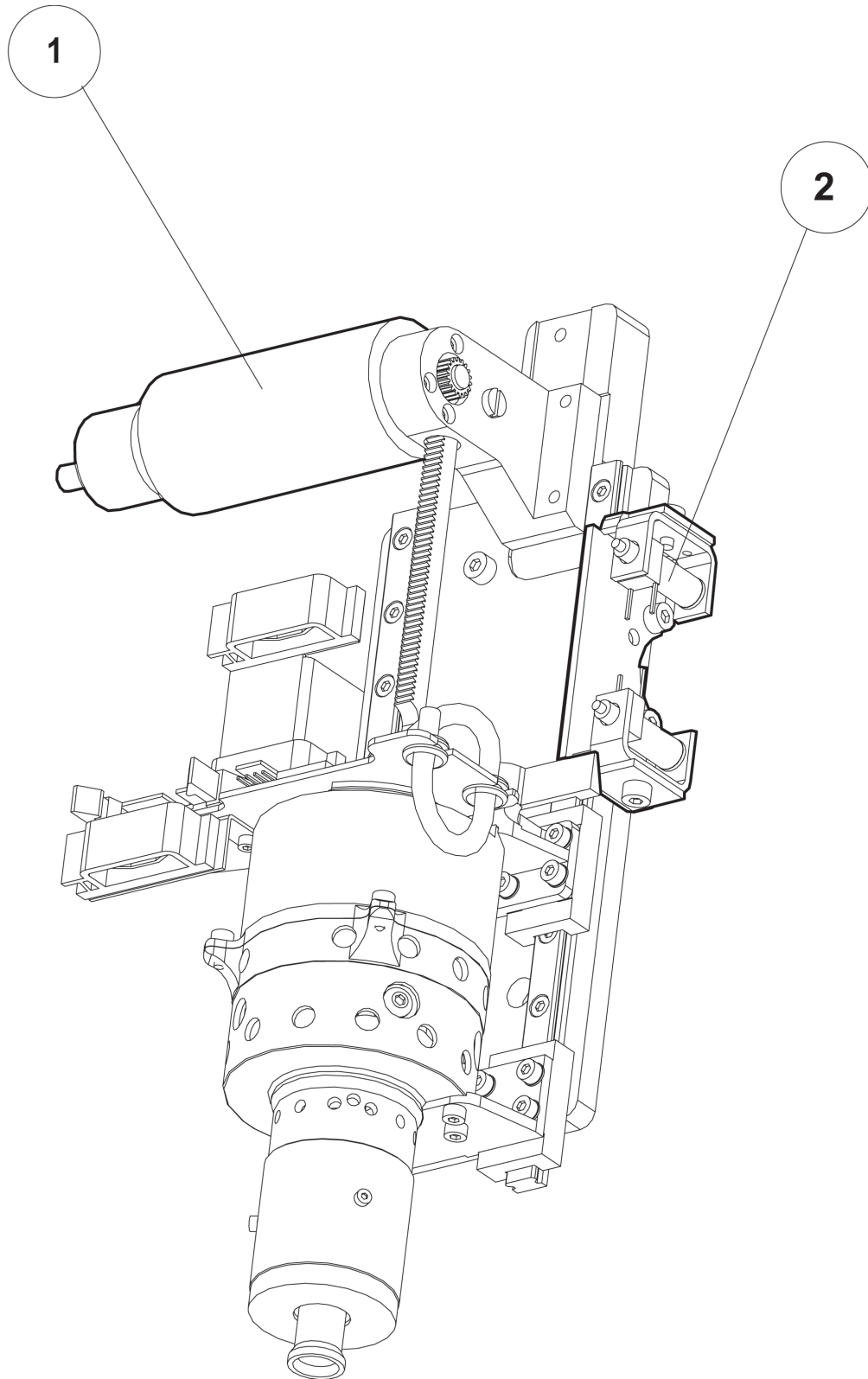

### Z-motor, Midas

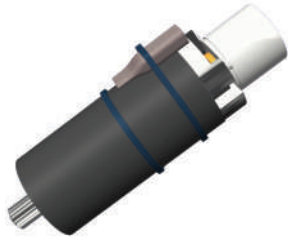

**Position:** 1

**Type of part:**  
Motor

**Part is replacing:**  
L-022-0105

**Machine type:**  
MY9 , MY12 , MY15 , MY19

**Requirements:**  
Midas

Part no.	Product name
L-022-0105B	Z-motor, Midas

### Z-lock bracket with magnets



**Position:** 2

**Type of part:**  
Kit

**Part is replacing:**  
L-022-0065

**Description**  
This Z-lock will fit both Z-Fi unit and Midas.

**Machine type:**  
MY12 , MY15 , MY19 , MY9 , TP11 , TP12 , TP18 , TP9-3 , TP9-4

Part no.	Product name
L-022-0065B	Z-lock bracket with magnets

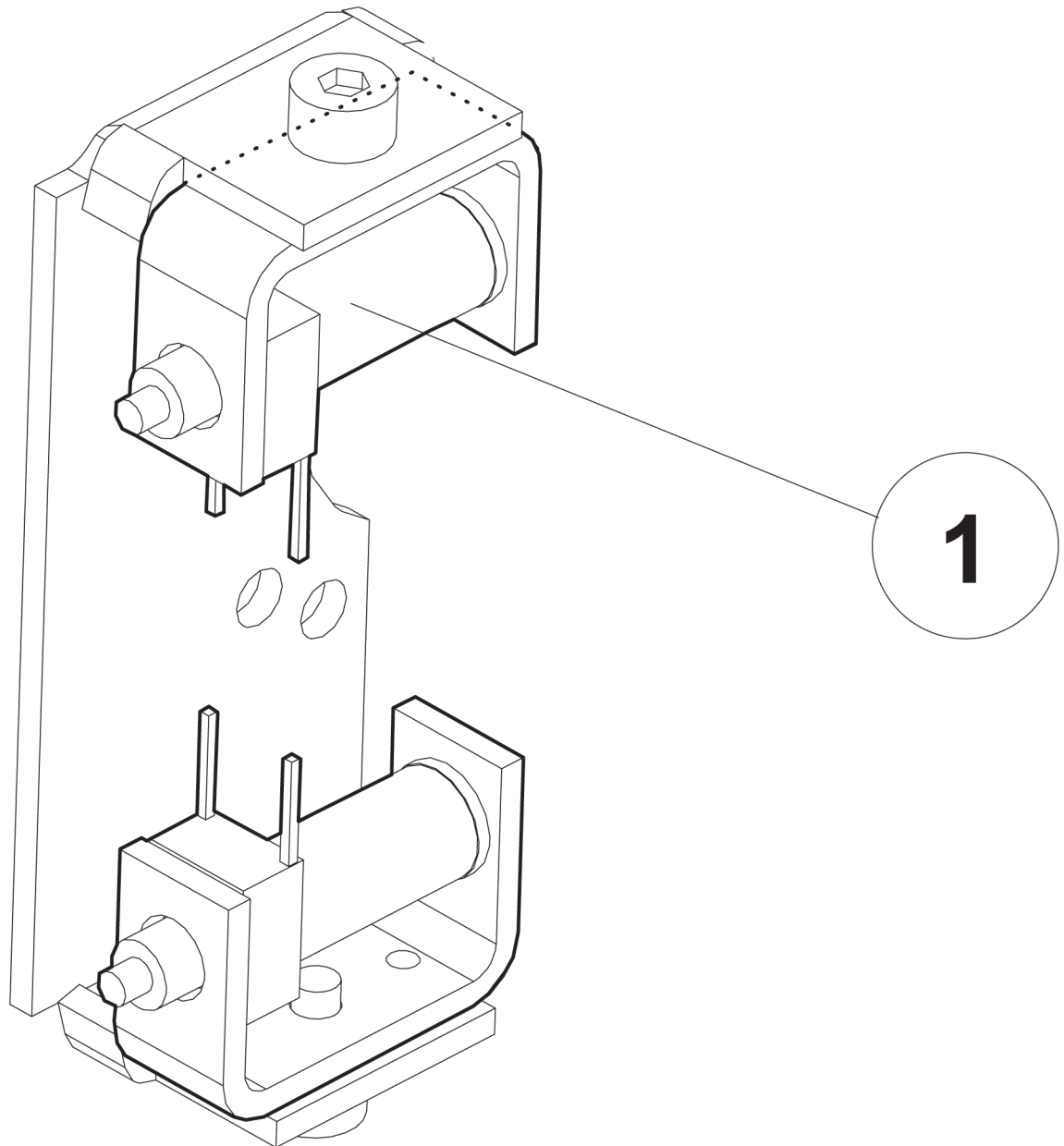

## Z-lock cable with solenoids



**Position:** 1

**Type of part:**  
Cable

**Part is replacing:**  
L-029-0191

**Machine type:**

MY12, MY15, MY19, MY9, TP11, TP12, TP18, TP9-1, TP9-2, TP9-3, TP9-4

**Requirements:**

TP9-1 and TP9-2 has to be upgraded with L-019-0100B before using this Z-lock.

Part no.	Product name
L-029-0191B	Z-lock cable with solenoids

## XFMB Fi motor board cable



**Type of part:**  
Cable

**Description**

Cable from FMB board to XWB(x) board.

**Machine type:**

MY12, MY15, MY19, MY9, TP11, TP12, TP18, TP9-3, TP9-4

Part no.	Product name
L-029-0193	XFMB Fi motor board cable

## Brushes, Set of 4



**Type of part:**  
Kit

**Description**

All four brushes have to be replaced at the same time.

**Machine type:**

MY12, MY15, MY19, MY9

**Requirements:**

Midas.

Part no.	Product name
K-022-0042	Brushes, Set of 4

## Silencer spare part kit

**Type of part:**

Kit

**Machine type:**

MY9, MY12, MY15, MY19

Part no.	Product name
L-022-0137	Silencer spare part kit

## Vacuum seal spare part kit

**Type of part:**

Kit

**Part is replacing:**

K-022-0038

**Machine type:**

MY9, MY12, MY15, MY19

Part no.	Product name
L-022-0136	Vacuum seal spare part kit

## ZFIB spare part kit

**Type of part:**

Kit

**Machine type:**

MY9, MY12, MY15, MY19

Part no.	Product name
L-049-0685	ZFIB spare part kit

### Vacuum tube



**Type of part:**  
Miscellaneous

**Part is replacing:**  
K-022-0045

#### Description

Vacuum tube for Midas unit.

#### Machine type:

MY12 , MY15 , MY19 , MY9

#### Requirements:

Midas.

Part no.	Product name
L-022-0120	Vacuum tube

### FFX Spare part kit



**Type of part:**  
PCB

**Part is replacing:**  
L-029-0366-2

#### Description

Z-sensor for Midas.

#### Machine type:

MY12 , MY15 , MY19 , MY9

Part no.	Product name
L-029-0555	FFX Spare part kit





**Printer cable**



**Type of part:**  
Cable

**Description**

Cable from Printer to P4-CP2.

**Machine type:**

TP9-1 , TP9-2

**Requirements:**

SYS 2.9

Part no.	Product name
L-019-0131	Printer cable

Part no.	Product name
E-040-0050	LAMP 24, 3W BA15S

**Drum for OKI B4300/B4350**

**Type of part:**

Miscellaneous

**Machine type:**

TP9-1 , TP9-2 , TP9-3 , TP9-4 , TP11 , TP12 , TP18 , MY9 , MY12 , MY15 , MY19

Part no.	Product name
K-040-0195	Drum for OKI B4300/B4350

**Printer cable**



**Type of part:**  
Cable

**Description**

Cable between Machine and Printer.

**Machine type:**

MY12 , MY15 , MY19 , MY9 , TP11 , TP12 , TP18 , TP9-1 , TP9-2 , TP9-3 , TP9-4

Part no.	Product name
K-019-0207	Printer cable



**Type of part:**  
Miscellaneous

**Description**

Ink ribbon for printer Fujitsu DL3700.

**Machine type:**

MY12 , MY15 , MY19 , MY9 , TP11 , TP12 , TP18 , TP9-1 , TP9-2 , TP9-3 , TP9-4

Part no.	Product name
K-010-0045	Ink ribbon Fujitsu DL3700

**LAMP 24, 3W BA15S**



**Type of part:**  
Electrical component

**Machine type:**

MY12 , MY15 , MY19 , MY9 , TP11 , TP12 , TP18 , TP9-2 , TP9-3 , TP9-4

**Postscript DIMM**

**Type of part:**

Miscellaneous

**Description**

For upgrading OKI B4300 to Postscript capability.

**Machine type:**

TP9-1 , TP9-2 , TP9-3 , TP9-4 , TP11 , TP12 , TP18 , MY9 , MY12 , MY15 , MY19

**Requirements:**

Printer OKI B4300

Part no.	Product name
K-040-0196	Postscript DIMM

### Toner for OKI B4300/B4350

**Type of part:**  
Miscellaneous

**Machine type:**  
TP9-1 , TP9-2 , TP9-3 , TP9-4 , TP11 , TP12 , TP18 , MY9 , MY12 , MY15 , MY19

Part no.	Product name
K-040-0194	Toner for OKI B4300/B4350

### Drum OKI 14i



**Type of part:**  
Unit

**Description**  
Drum for printer OKI 14i - L-040-1078.

**Machine type:**  
MY12 , MY15 , MY19 , MY9 , TP11 , TP12 , TP18 , TP9-1 , TP9-2 , TP9-3 , TP9-4

Part no.	Product name
K-040-0132	Drum OKI 14i

### Printer Fujitsu DL3700



**Type of part:**  
Unit

**Machine type:**  
MY12 , MY15 , MY19 , MY9 , TP11 , TP12 , TP18 , TP9-1 , TP9-2 , TP9-3 , TP9-4

**Requirements:**  
TPSys 1.4 or earlier. For TPSys 1.5 or later - use printer OKI 14i - L-040-1078

Part no.	Product name
K-010-0042	Printer Fujitsu DL3700

### Printer OKI B4350nPS



**Type of part:**  
Unit

**Description**  
Printer complete with installation manual.

**Machine type:**  
MY12 , MY15 , MY19 , MY9 , TP11 , TP12 , TP18 , TP9-1 , TP9-2 , TP9-3 , TP9-4

**Requirements:**  
TPSys 1.5 or later. See printer Fujitsu DL3700 - K-010-0042 for TPSys 1.4 or earlier.

Part no.	Product name
L-040-1078	Printer OKI B4350nPS

### Toner OKI 14i



**Type of part:**  
Unit

**Description**  
Toner for printer OKI 14i

**Machine type:**  
MY12 , MY15 , MY19 , MY9 , TP11 , TP12 , TP18 , TP9-1 , TP9-2 , TP9-3 , TP9-4

Part no.	Product name
K-040-0133	Toner OKI 14i

**Set of 3 C14 tool tips**



**Type of part:**  
Kit

**Description**

Black PEEK tool tip.

**Machine type:**

TP9-1 , TP9-2 , TP9-3 , TP9-4 , TP11 , TP12 , TP18 , MY9 , MY12 , MY15 , MY19

**Requirements:**

C14 tool - L-012-0802

Part no.	Product name
L-012-0823	Set of 3 C14 tool tips

**Machine type:**

MY12 , MY15 , MY19 , MY9 , TP11 , TP12 , TP18 , TP9-1 , TP9-2 , TP9-3 , TP9-4

Part no.	Product name
D-012-0263D-4	Tool tip A12, PEEK

**Tool tip A13**



**Type of part:**  
Mechanical component

**Machine type:**

TP9-1 , TP9-2 , TP9-3 , TP9-4 , TP11 , TP12 , TP18 , MY9 , MY12 , MY15 , MY19

**Requirements:**

A13 tool - L-012-0012F

Part no.	Product name
D-012-1162	Tool tip A13

**Set of 3 B12 tool tips**

**Type of part:**

Kit

**Machine type:**

MY9 , MY12 , MY15 , MY19

Part no.	Product name
L-012-0885	Set of 3 B12 tool tips

**Tool tip A14, Black PEEK**



**Type of part:**  
Mechanical component

**Part is replacing:**  
D-012-0408-4

**Tool tip A12, PEEK**



**Type of part:**  
Mechanical component

**Description**

Black PEEK tool tip.

**Machine type:**

TP9-1 , TP9-2 , TP9-3 , TP9-4 , TP11 , TP12 , TP18 , MY9 , MY12 , MY15 , MY19

Part no.	Product name
D-012-0408B	Tool tip A14, Black PEEK

**Description**

Black PEEK tool tip.

### Tool tip A23S



**Type of part:**  
Mechanical component

**Description**

Replacement tip for Tool A23S - L-012-0551B.

**Machine type:**

TP9-1 , TP9-2 , TP9-3 , TP9-4 , TP11 , TP12 , TP18 , MY9 , MY12 , MY15 , MY19

Part no.	Product name
L-012-0540	Tool tip A23S

### Tool tip A34, Black PEEK



**Type of part:**  
Mechanical component

**Part is replacing:**  
D-012-0308B-4

**Description**

Black PEEK tool tip.

**Machine type:**

TP9-1 , TP9-2 , TP9-3 , TP9-4 , TP11 , TP12 , TP18 , MY9 , MY12 , MY15 , MY19

Part no.	Product name
D-012-0308C	Tool tip A34, Black PEEK

### Tool tip A24S



**Type of part:**  
Mechanical component

**Description**

Replacement tip for Tool A24S - L-012-0552B.

**Machine type:**

MY12 , MY15 , MY19 , MY9 , TP11 , TP12 , TP18 , TP9-1 , TP9-2 , TP9-3 , TP9-4

Part no.	Product name
L-012-0542	Tool tip A24S

### Tool tip B23, Black PEEK



**Type of part:**  
Mechanical component

**Part is replacing:**  
D-012-0248C-4

**Description**

Black PEEK tool tip.

**Machine type:**

TP9-1 , TP9-2 , TP9-3 , TP9-4 , TP11 , TP12 , TP18 , MY9 , MY12 , MY15 , MY19

Part no.	Product name
D-012-0248D	Tool tip B23, Black PEEK

**Tool tip B24, Black PEEK**



**Type of part:**  
Mechanical component

**Part is replacing:**  
D-012-0255C-4

**Description**  
Black PEEK tool tip

**Machine type:**  
TP9-1 , TP9-2 , TP9-3 , TP9-4 , TP11 , TP12 , TP18 , MY9 , MY12 , MY15 , MY19

Part no.	Product name
D-012-0255D	Tool tip B24, Black PEEK

**Tool tip C14, Black PEEK**



**Type of part:**  
Mechanical component

**Description**  
Black PEEK tool tip

**Machine type:**  
MY12 , MY15 , MY19 , MY9 , TP11 , TP12 , TP18 , TP9-1 , TP9-2 , TP9-3 , TP9-4

**Requirements:**  
Older non-black C14 tool delivered with PEEK tool tip.

Part no.	Product name
D-012-0282B-4	Tool tip C14, Black PEEK

**Tool tip B34, Black PEEK**



**Type of part:**  
Mechanical component

**Part is replacing:**  
D-012-0404B-4

**Description**  
Black PEEK tool tip.

**Machine type:**  
TP9-1 , TP9-2 , TP9-3 , TP9-4 , TP11 , TP12 , TP18 , MY9 , MY12 , MY15 , MY19

Part no.	Product name
D-012-0404C	Tool tip B34, Black PEEK

**Tool tip C23S**



**Type of part:**  
Mechanical component

**Part is replacing:**  
L-012-0381

**Description**  
Replacement tip for tool C23S.

**Machine type:**  
TP9-1 , TP9-2 , TP9-3 , TP9-4 , TP11 , TP12 , TP18 , MY9 , MY12 , MY15 , MY19

Part no.	Product name
L-012-0381B	Tool tip C23S

**Tool tip MELF 3.3**

**Type of part:**  
Mechanical component

**Machine type:**

TP9-1 , TP9-2 , TP9-3 , TP9-4 , TP11 , TP12 , TP18 , MY9 , MY12 , MY15 , MY19

**Requirements:**

Tool C24 MELF 3.3 - L-012-0848

Part no.	Product name
D-012-0857	Tool tip MELF 3.3

**Tool tip MELF 4.5**

**Type of part:**

Mechanical component

**Machine type:**

TP9-1 , TP9-2 , TP9-3 , TP9-4 , TP11 , TP12 , TP18 , MY9 , MY12 , MY15 , MY19

**Requirements:**

Tool C24 MELF 4.5 - L-012-0849

Part no.	Product name
D-012-0879	Tool tip MELF 4.5

**Tool tip MELF 7.7**

**Type of part:**

Mechanical component

**Machine type:**

TP9-1 , TP9-2 , TP9-3 , TP9-4 , TP11 , TP12 , TP18 , MY9 , MY12 , MY15 , MY19

**Requirements:**

Tool C24 MELF 7.7 - L-012-0850

Part no.	Product name
D-012-0284-4	Tool tip MELF 7.7

**Grease paste**



**Type of part:**  
Miscellaneous

**Description**

For o-rings on placement tools.

Type: OKS 270

**Machine type:**

MY12 , MY15 , MY19 , MY9 , TP11 , TP12 , TP18 , TP9-1 , TP9-2 , TP9-3 , TP9-4

Part no.	Product name
K-013-0014	Grease paste

**O-ring 4.6x2.4**

**Type of part:**

Miscellaneous

**Part is replacing:**

M-0946

**Description**

O-ring for placement tools

**Machine type:**

TP9-2 , TP9-3 , TP9-4 , TP11 , TP12 , TP18 , MY9 , MY12 , MY15 , MY19

Part no.	Product name
M-1553	O-ring 4.6x2.4

**Omega 28 tube 15g**

**Type of part:**

Miscellaneous

**Description**

For o-rings on placement tools. Only to be used on machines with Midas mounthead.

Type: Omega 28

**Machine type:**

MY9 , MY12 , MY15 , MY19

Part no.	Product name
L-012-0860	Omega 28 tube 15g

Run-time clock



Part no.	Product name
K-019-0130	Run-time clock 220V 50Hz
K-019-0130-B	Run-time clock 117V, 60Hz

UPS for PC server



**Requirements:**  
TPSys 2.2.5, TPSys 2.3.2 or later for automatic shutdown of server.

Part no.	Product name
L-019-1107	UPS for PC server 120VAC
L-019-1106	UPS for PC server 230VAC

XNET voltage plug



Description

TP9-4/TP11 100V single phase connection.  
TP12/18 175V three phase wye connection.

Part no.	Product name
L-029-0293-1	XNET voltage 175/100V
L-029-0292-1	XNET voltage 190/110V
L-029-0289-3	XNET voltage 200/115V
L-029-0288-3	XNET voltage 210/121V
L-029-0428-1	XNET voltage 215/125V

Part no.	Product name
L-029-0290-1	XNET voltage 220/127V
L-029-0427-1	XNET voltage 225/130V
L-029-0426-1	XNET voltage 230/133V
L-029-0425-1	XNET voltage 235/136V
L-029-0424-1	XNET voltage 240/140V
L-029-0423-1	XNET voltage 250/145V
L-029-0422-1	XNET voltage 345/200V
L-029-0362-1	XNET voltage 365/210V
L-029-0287-1	XNET voltage 370/215V
L-029-0286-1	XNET voltage 380/220V
L-029-0285-1	XNET voltage 390/225V
L-029-0284-3	XNET voltage 400/230V
L-029-0291-1	XNET voltage 410/235V
L-029-0283-3	XNET voltage 415/240V
L-029-0282-1	XNET voltage 435/250V

XNET voltage plug TP9-2



Part no.	Product name
L-029-0361-2	XNET voltage 100V
L-029-0358-2	XNET voltage 110V
L-029-0359-2	XNET voltage 115V
L-029-0360-3	XNET voltage 125V

Cordset IEC-US 7m

**Type of part:**  
Cable

**Machine type:**  
TP9-2

Part no.	Product name
K-019-0372	Cordset IEC-US 7m



### Mains input cable Euro standard



**Type of part:**  
Cable

**Machine type:**  
MY12, MY15, MY19, MY9, TP11, TP12, TP18, TP9-1, TP9-2, TP9-3, TP9-4

Part no.	Product name
K-019-0337	Mains input cable Euro standard

### UPS-Sever cable



**Type of part:**  
Cable

**Description**  
For Patriot UPS.

**Machine type:**  
MY9, MY12, MY15, MY19

Part no.	Product name
L-049-0272	UPS-Sever cable

### Mains input cable US standard



**Type of part:**  
Cable

**Description**  
For PC-Server.

**Machine type:**  
TP9-1, TP9-2, TP9-3, TP9-4, TP11, TP12, TP18, MY9, MY12, MY15, MY19

Part no.	Product name
K-019-0276	Mains input cable US standard

### XBOF M-Booster flat cable



**Type of part:**  
Cable

**Description**  
Cable from Computer Box to Booster.

**Machine type:**  
MY12, MY15, MY19, MY9

Part no.	Product name
L-049-0012	XBOF M-Booster flat cable

### UPS-Server cable

**Type of part:**  
Cable

**Machine type:**  
MY9, MY12, MY15, MY19

**Requirements:**  
Powerware 5115

Part no.	Product name
L-049-0473	UPS-Server cable

### BATTERY 12V 7AH, UPS 151X65X94



**Type of part:**  
Electrical component

**Description**  
Battery for Patriot UPS.

**Machine type:**  
TP9-1, TP9-2, TP9-3, TP9-4, TP11, MY9, MY12, MY15, MY19

Part no.	Product name
E-053-0002	BATTERY 12V 7AH, UPS 151X65X94

### Battery Hitachi 10 Ah 6 V



**Type of part:**  
Electrical component

**Description**  
For battery backup.

**Machine type:**  
TP9-1, TP9-2, TP9-3, TP9-4, TP11, TP12, TP18, MY9, MY12, MY15, MY19

Part no.	Product name
E-053-0001	Battery Hitachi 10 Ah 6 V

### Elmo safety relay



**Type of part:**  
Electrical component

**Machine type:**  
MY12, MY15, MY19, MY9

Part no.	Product name
L-029-0344-1	Elmo safety relay

### Fuse kit Power Supply



**Type of part:**  
Electrical component

**Description**  
10 x Fuse quick 0.1A 32mm  
10 x Fuse slow 10A 32mm  
10 x Fuse slow 6.3A 32mm  
10 x Fuse slow 15A 32mm  
10 x Fuse slow 20A 32mm

**Machine type:**  
MY12, MY15, MY19, MY9, TP11, TP9-2, TP9-4

**Requirements:**  
PS ed. 7 or later. PS2 ed. 5 or later. PS3 ed. 2 and later.

Part no.	Product name
L-019-1000	Fuse kit Power Supply

### Power relay



**Type of part:**  
Electrical component

**Machine type:**  
TP11, TP12, TP18, TP9-1, TP9-2, TP9-3, TP9-4

Part no.	Product name
E-013-0102B	Power relay

### Relay 220V AC 2VX



**Type of part:**  
Electrical component

**Machine type:**  
TP9-1, TP9-2, TP9-3, TP9-4, TP11, TP12, TP18

Part no.	Product name
E-013-0003	Relay 220V AC 2VX

### Relay emergency stop 24V

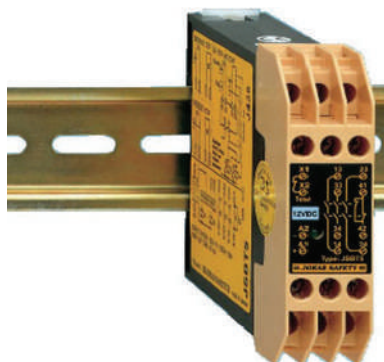

**Type of part:**  
Electrical component

**Part is replacing:**  
E-013-0008

**Description**  
JSBT5

**Machine type:**  
TP9-2 , TP9-4 , TP11 , TP12 , TP18 , MY9 , MY12 , MY15 , MY19

Part no.	Product name
E-013-0017	Relay emergency stop 24V

**Description**  
Only for Japan.

**Machine type:**  
MY12 , MY15 , MY19 , MY9 , TP12 , TP18

Part no.	Product name
L-029-0297	XY/D DELTA connection

### XY/D DELTA connection



**Type of part:**  
Electrical component

**Part is replacing:**  
L-029-0296

**Machine type:**  
MY12 , MY15 , MY19 , MY9 , TP12 , TP18

Part no.	Product name
L-029-0296-3	XY/D DELTA connection

### Run-time clock

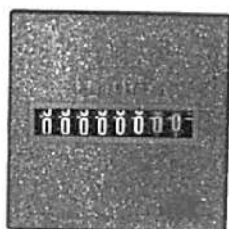

**Type of part:**  
Electrical component

**Machine type:**  
MY12 , MY15 , MY19 , MY9 , TP11 , TP12 , TP18 , TP9-1 , TP9-2 , TP9-3 , TP9-4

Part no.	Product name
K-019-0222	Run-time clock

### XY/D WYE connection



**Type of part:**  
Electrical component

**Part is replacing:**  
L-029-0295

**Machine type:**  
MY12 , MY15 , MY19 , MY9 , TP12 , TP18

Part no.	Product name
L-029-0295-3	XY/D WYE connection

### XY/D DELTA connection



**Type of part:**  
Electrical component

Fuse kit

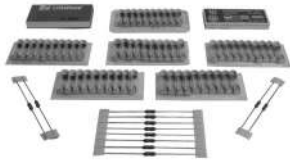

Type of part:  
Kit

Description

- 10 x Fuse quick 1A 20mm
- 10 x Fuse quick 4A 20mm
- 10 x Fuse quick 100mA 20mm
- 10 x Fuse quick 8A 20mm
- 10 x Fuse quick 2A 20mm
- 10 x Fuse quick 6.3A 20mm
- 10 x Fuse quick 10A 20mm
- 10 x Fuse slow 400mA 20mm
- 5 x Fuse ultraquick 62mA (Picdfuse)
- 5 x Fuse ultraquick 1.5A (Picofuse)
- 2 x Tranzorb 24V 600W
- 5 x Fuse ultraquick 4 A (Picofuse)

Machine type:

TP9-1 , TP9-2

Part no.	Product name
L-019-0128	Fuse kit

Fuse kit

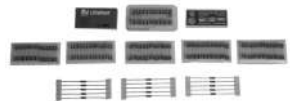

Type of part:  
Kit

Description

- 10 x Fuse quick 100mA 20mm
- 10 x Fuse quick 1A 20mm
- 10 x Fuse quick 4A 20mm
- 10 x Fuse quick 8A 20mm
- 10 x Fuse quick 2A 20mm
- 10 x Fuse quick 6.3A 20mm
- 10 x Fuse quick 10A 20mm
- 10 x Fuse slow 400mA 20mm
- 2 x Fuse ultraquick 62mA (Picdfuse)
- 8 x Fuse ultraquick 1.5A (Picofuse)
- 2 x Tranzorb 24V 600W
- 2 x Fuse ultraquick 4 A (Picofuse)

Machine type:

TP9-3 , TP9-4 , TP11

Part no.	Product name
L-019-0487	Fuse kit

Fuse kit MY-Series

Type of part:  
Kit

Part is replacing:

L-049-0102

Description

- 20 pcs Fuse quick 1.6A 20mm
- 10 pcs Fuse quick 4A 20mm
- 20 pcs Fuse quick 8A 20mm
- 20 pcs Fuse quick 2A 20mm
- 10 pcs Fuse quick 6.3A 20mm
- 10 pcs Fuse quick 0,1A 32mm
- 20 pcs Fuse slow 10A 6.3\*32mm
- 10 pcs Fuse slow 6.3A 6.3\*32mm
- 30 pcs Fuse slow 15A 6.3\*32mm
- 10 pcs Fuse slow 20A 6.3\*32mm
- 15 pcs Fuse slow 8A 6.3\*32mm

Machine type:

MY12 , MY15 , MY19 , MY9

Part no.	Product name
L-049-0102B	Fuse kit MY-Series

UPS Powerware 3110 upgrade kit

Type of part:

Kit

Description

Includes auto-transformer which will raise the input voltage for the Powerware 3110 UPS if having problem with low input voltage.

Machine type:

MY9 , MY12 , MY15 , MY19

Part no.	Product name
L-049-0677	UPS Powerware 3110 upgrade kit

UPS replacement

Type of part:

Kit

Part is replacing:

K-049-0171

Machine type:

MY9 , MY12 , MY15 , MY19

Ordering info:

If replacing a Joviatlas or Compact fit UPS the Box 5/12V must be replaced by a 120V version - L-049-0604.

Part no.	Product name
L-049-0678	UPS replacement

### UPS spare part for Powerware 3110 with AT

**Type of part:**  
Kit

**Description**  
For replacing Powerware 3110 UPS with autotransformer connected between PS3 and UPS.

**Machine type:**  
MY9 , MY12 , MY15 , MY19

Part no.	Product name
L-049-0687	UPS spare part for Powerware 3110 with AT

### UPS spare part with box 12V/5V

**Type of part:**  
Kit

**Part is replacing:**  
K-049-0150

**Description**  
Kit for replacing UPS if having other than Powerware 3110 UPS.

**Machine type:**  
MY9 , MY12 , MY15 , MY19

Part no.	Product name
L-049-0608	UPS spare part with box 12V/5V

### UPS spare part with box 12V/5V

**Type of part:**  
Kit

**Description**  
For replacing UPS-400SA, Jovyatlas or UPS Compact-Fit 400 unit.

**Machine type:**  
MY9 , MY12 , MY15 , MY19

Part no.	Product name
L-049-0686	UPS spare part with box 12V/5V

### Fuse kit



**Type of part:**  
Miscellaneous

**Description**  
5 x Fuse quick 2A 32mm  
5 x Fuse quick 10A 32mm  
5 x Fuse quick 15A 32mm  
5 x Fuse quick 20A 32mm  
5 x Fuse quick 100mA 32mm  
2 x Fuse ultraquick 62mA (Picofuse)  
2 x Fuse ultraquick 1.5A (Picofuse)  
2 x Fuse ultraquick 4 A (Picofuse)

**Machine type:**  
TP12 , TP18

Part no.	Product name
L-029-0250	Fuse kit

### Box 12V 5V /120VAC

**Type of part:**  
Unit

**Machine type:**  
MY9 , MY12 , MY15 , MY19

**Requirements:**  
UPS with 120V output.

Part no.	Product name
L-049-0604	Box 12V 5V /120VAC

### Emergency relay connector



**Type of part:**  
Unit

**Machine type:**  
TP9-1 , TP9-2 , TP9-3

Part no.	Product name
L-019-0593	Emergency relay connector

### EPT2 edition 3, Elmo Power Transformer

**Type of part:**  
Unit

**Part is replacing:**  
L-049-0111-2

**Machine type:**  
MY9 , MY12 , MY15 , MY19

Part no.	Product name
L-049-0111-3	EPT2 edition 3, Elmo Power Transformer

### Mains input unit

**Type of part:**  
Unit

**Part is replacing:**  
L-049-0064-3

**Machine type:**  
MY9 , MY12 , MY15 , MY19

Part no.	Product name
L-049-0064-4	Mains input unit

### Power supply



**Type of part:**  
Unit

**Part is replacing:**  
L-019-0009-6

**Machine type:**  
TP9-1 , TP9-2 , TP9-3

Part no.	Product name
L-019-0009-8	Power supply

### Power supply 2



**Type of part:**  
Unit

**Part is replacing:**  
L-019-0011-5

**Machine type:**  
TP9-4 , TP11

Part no.	Product name
L-019-0011-6	Power supply 2

### Power supply 3

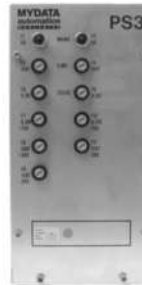

**Type of part:**  
Unit

**Part is replacing:**  
L-019-0022-1

**Machine type:**  
MY12 , MY15 , MY19 , MY9 , TP9-2 , Tray Exchanger

Part no.	Product name
L-019-0022-3	Power supply 3

### PS4 - power supply

**Type of part:**  
Unit

**Machine type:**  
TP9-2 , MY9 , MY12 , MY15 , MY19

Part no.	Product name
L-049-0591	PS4 - power supply

### UPS EBK-350 with plastic feet

**Type of part:**  
Unit

**Description:**  
Powercom EBK-350

**Machine type:**  
MY9 , MY12 , MY15 , MY19

<b>Part no.</b>	<b>Product name</b>
L-049-0661	UPS EBK-350 with plastic feet

### Calibration plate

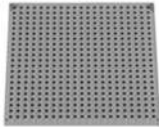

**Type of part:**  
Mechanical component

**Description**  
For calibrating the OVS camera.

**Machine type:**  
TP9-1 , TP9-2

Part no.	Product name
D-019-0377D-4	Calibration plate

### Accuracy test board 1 ed. 3

**Type of part:**  
Miscellaneous

**Part is replacing:**  
L-029-0243-2

**Description**  
Board for calibrating and testing Positioning Vision System.

**Machine type:**  
TP9-1 , TP9-2 , TP9-3 , TP9-4 , TP11 , TP12 , TP18 , MY9 , MY12 , MY15 , MY19

**Requirements:**  
TPSys 1.6.13 or later versions of TPSys.

Part no.	Product name
L-029-0243-3	Accuracy test board 1 ed. 3

### Area calibration background 254\*456

**Type of part:**  
Miscellaneous

**Machine type:**  
TP9-1 , TP9-2 , TP9-3 , TP9-4 , TP11 , TP12 , TP18 , MY9 , MY12 , MY15 , MY19

**Requirements:**  
TPSys 2.4.3 or later version, Board handling system 288, 298 or 358

Part no.	Product name
L-015-1681	Area calibration background 254*456

### Area calibration background 384\*508

**Type of part:**  
Miscellaneous

**Machine type:**  
MY9 , MY12 , MY15 , MY19

**Requirements:**  
TPSys 2.4.3 or later version, Board handling system ML3

Part no.	Product name
L-015-1682	Area calibration background 384*508

### Area calibration background 400\*590

**Type of part:**  
Miscellaneous

**Machine type:**  
TP9-4 , TP11 , MY9 , MY12 , MY15 , MY19

**Requirements:**  
TPSys 2.4.3 or later version, Board handling system 400PT.

Part no.	Product name
L-015-1683	Area calibration background 400*590

### Area calibration background 427\*461

**Type of part:**  
Miscellaneous

**Machine type:**  
TP9-1 , TP9-2 , TP9-3 , TP9-4 , TP11 , TP12 , TP18 , MY9 , MY12 , MY15 , MY19

**Requirements:**  
TPSys 2.4.3 or later version, Board handling system 468, 478, 538, 500T2 with ML Adapter or 450PT.

Part no.	Product name
L-015-1684	Area calibration background 427*461

### Area calibration background 440\*508

**Type of part:**  
Miscellaneous

**Machine type:**  
TP9-1 , TP9-2 , TP9-3 , TP9-4 , TP11 , TP12 , TP18 , MY9 , MY12 , MY15 , MY19



**Requirements:**

TPSys 2.4.3 or later version, Board handling system for 500T, 500T2 or T3.

Part no.	Product name
L-015-1685	Area calibration background 440*508

**Area calibration background 563\*508****Type of part:**

Miscellaneous

**Machine type:**

TP9-4 , TP11 , MY9 , MY12 , MY15 , MY19

**Requirements:**

TPSys 2.4.3 or later version, Board handling system ML4, T4 or 500T2 extended

Part no.	Product name
L-015-1686	Area calibration background 563*508

**Area calibration background 736\*609****Type of part:**

Miscellaneous

**Machine type:**

MY9 , MY12 , MY15 , MY19

**Requirements:**

TPSys 2.4.3 or later version, Board handling system T5 or ML5

Part no.	Product name
L-015-1687	Area calibration background 736*609

**Area calibration background 914\*609****Type of part:**

Miscellaneous

**Machine type:**

MY9 , MY12 , MY15 , MY19

**Requirements:**

TPSys 2.4.3 or later version, Board handling system T6

Part no.	Product name
L-015-1688	Area calibration background 914*609

**Area calibration background 927\*732****Type of part:**

Miscellaneous

**Machine type:**

MY9 , MY12 , MY15 , MY19

**Requirements:**

TPSys 2.4.3 or later version, Board handling system ML6

Part no.	Product name
L-015-1689	Area calibration background 927*732

**Area calibration plate****Type of part:**

Miscellaneous

**Machine type:**

TP9-1 , TP9-2 , TP9-3 , TP9-4 , TP11 , TP12 , TP18 , MY9 , MY12 , MY15 , MY19

**Requirements:**

TPSys 2.4.3 or later version.

Part no.	Product name
L-012-0634	Area calibration plate

**BJS calibration plate with label****Type of part:**

Miscellaneous

**Machine type:**

TP9-1 , TP9-2 , TP9-3 , TP9-4 , TP11 , TP12 , TP18 , MY9 , MY12 , MY15 , MY19

Part no.	Product name
L-015-0452	BJS calibration plate with label

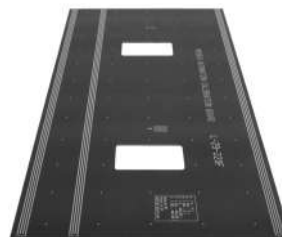
**Calibration board****Type of part:**

Miscellaneous

**Machine type:**

MY12 , MY15 , MY19 , MY9 , TP11 , TP12 , TP18 , TP9-1 , TP9-2 , TP9-3 , TP9-4

**Requirements:**

TPSys 1.6.13 or earlier TPSys versions.

Part no.	Product name
L-029-0220F	Calibration board

**Calibration components**

**Type of part:**

Miscellaneous

**Machine type:**

TP9-1 , TP9-2 , TP9-3 , TP9-4 , TP11 , TP12 , TP18 , MY9 , MY12 , MY15 , MY19

**Requirements:**

TPSys 2.4.3 or later version.

Part no.	Product name
L-012-0633	Calibration components

**Calibration plate**

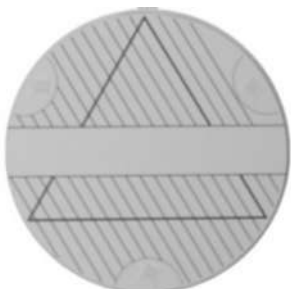

**Type of part:**  
Miscellaneous

**Machine type:**

MY12 , MY15 , MY19 , MY9

**Requirements:**

Linescan Vision System.

Part no.	Product name
L-010-0452B	Calibration plate

**Calibration plate**

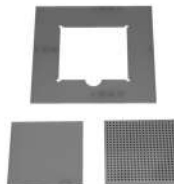

**Type of part:**  
Miscellaneous

**Machine type:**

TP9-1 , TP9-2

**Requirements:**

SYS 2.9

Part no.	Product name
L-019-0329	Calibration plate

**Calibration plate**



**Type of part:**  
Miscellaneous

**Description**

For calibrating OVS and SVS camera.

**Machine type:**

TP11 , TP12 , TP18 , TP9-1 , TP9-2 , TP9-3 , TP9-4

**Requirements:**

TPSys

Part no.	Product name
L-019-0447	Calibration plate

**Hexagonal key 263, 0.9x40**



**Type of part:**  
Miscellaneous

**Description**

Used for 0.9mm hexagonal screws on small cogwheels.

**Machine type:**

MY12 , MY15 , MY19 , MY9 , TP11 , TP12 , TP18 , TP9-1 , TP9-2 , TP9-3 , TP9-4

Part no.	Product name
M-1164	Hexagonal key 263, 0.9x40

### Optical calibration plate Hydra Camera

**Type of part:**  
Miscellaneous

**Part is replacing:**  
L-019-0633-2

**Machine type:**  
TP9-4 , TP11 , MY9 , MY12 , MY15 , MY19

Part no.	Product name
L-019-0107	Optical calibration plate Hydra Camera

### Optical calibration plate kit SVC & HRC

**Type of part:**  
Miscellaneous

**Part is replacing:**  
L-029-0506

**Machine type:**  
TP9-1 , TP9-2 , TP9-3 , TP9-4 , TP11 , TP12 , TP18 , MY9 , MY12 , MY15 , MY19

Part no.	Product name
L-019-0108	Optical calibration plate kit SVC & HRC

### TP9 Calibration board

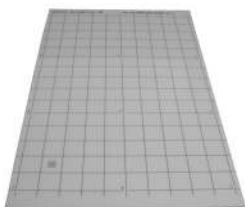

**Type of part:**  
Miscellaneous

**Description**  
Place area calibration board.

**Machine type:**  
TP9-1 , TP9-2

**Requirements:**  
SYS 2.9

Part no.	Product name
L-019-0328-2	TP9 Calibration board

### Adjustment tool steering wheel



**Type of part:**  
Special MYDATA tool

**Description**  
Tool for adjusting play on guide wheels on X Wagon.

**Machine type:**  
TP9-3 , TP9-4 , TP11 , TP12 , TP18

Part no.	Product name
D-007-0018-3	Adjustment tool steering wheel

### Adjustment tool, smaller



**Type of part:**  
Special MYDATA tool

**Description**  
Tool for adjusting play on guide wheels on X Wagon.

**Machine type:**  
TP9-3 , TP9-4 , TP11

Part no.	Product name
D-007-0019-3	Adjustment tool, smaller

### Assembly-jig O-rings



**Type of part:**  
Special MYDATA tool

**Description**  
Tool for assemble o-rings on placement tools.

**Machine type:**  
MY12 , MY15 , MY19 , MY9 , TP11 , TP12 , TP18 , TP9-1 , TP9-2 , TP9-3 , TP9-4

Part no.	Product name
D-012-0158B-4	Assembly-jig O-rings

### Assembly tool for Z-mid. axle



**Type of part:**  
Special MYDATA tool

#### Description

Tool to be used when replacing z-middle axle (L-022-0073) on Z-Fi unit - L-022-0050 and L-022-0066.

#### Machine type:

TP11, TP12, TP18, TP9-3, TP9-4

Part no.	Product name
D-007-0016-3	Assembly tool for Z-mid. axle

### Grease Gun for X-rail



**Type of part:**  
Special MYDATA tool

#### Machine type:

MY12, MY15, MY19, MY9, TP11, TP12, TP18, TP9-3, TP9-4

#### Requirements:

Use grease K-015-0091 when refilling Grease Gun.

Part no.	Product name
L-015-0395	Grease Gun for X-rail

### Grease Gun with Filter for YWU



**Type of part:**  
Special MYDATA tool

#### Machine type:

MY12, MY15, MY19, MY9, TP11, TP12, TP18, TP9-1, TP9-2, TP9-3, TP9-4

#### Requirements:

Use grease U-015-0014 when refilling Grease Gun.

Part no.	Product name
L-015-0397	Grease Gun with Filter for YWU

### HYDRA adjustment tool

#### Type of part:

Special MYDATA tool

#### Part is replacing:

L-012-0422

#### Machine type:

TP9-4, TP11, MY9, MY12, MY15, MY19

Part no.	Product name
L-012-0131	HYDRA adjustment tool

### LIE5 spacer 0.6mm



**Type of part:**  
Special MYDATA tool

#### Description

Spacer used for adjusting the Linescan encoder head.

#### Machine type:

MY12, MY15, MY19, MY9

Part no.	Product name
K-010-0352	LIE5 spacer 0.6mm

### O-ring mounter kit



**Type of part:**  
Special MYDATA tool

#### Description

For mounting o-rings on HYDRA tool tubes.

#### Machine type:

TP9-1, TP9-2, TP9-3, TP9-4, TP11, TP12, TP18, MY9, MY12, MY15, MY19

Part no.	Product name
L-012-0623	O-ring mounter kit

### Reference magazine



**Type of part:**  
Special MYDATA tool

**Description**  
For calibrating magazine slots.

**Machine type:**  
MY12 , MY15 , MY19 , MY9 , TP11 , TP12 , TP18 , TP9-1 , TP9-2 , TP9-3 , TP9-4

Part no.	Product name
L-007-0005	Reference magazine

### Retainer tool



**Type of part:**  
Special MYDATA tool

**Machine type:**  
MY12 , MY15 , MY19 , MY9 , TP11 , TP9-4

Part no.	Product name
D-012-0931	Retainer tool

### Tool for motor exchange, C-60

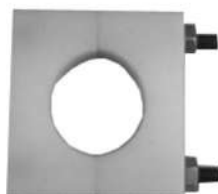

**Type of part:**  
Special MYDATA tool

**Machine type:**  
MY12 , MY15 , MY19 , MY9 , TP11 , TP12 , TP18 , TP9-3 , TP9-4

Part no.	Product name
L-007-0002	Tool for motor exchange, C-60

### Tool for steel-belt exchange



**Type of part:**  
Special MYDATA tool

**Machine type:**  
MY12 , MY15 , MY19 , MY9 , TP11 , TP12 , TP18 , TP9-3 , TP9-4

**Requirements:**  
C-60 centering device.

Part no.	Product name
L-007-0003	Tool for steel-belt exchange

### TPSys software kit

#### Description

For updating the current TPSys version to the latest release.  
Box with software and documentation.

#### Requirements:

TPSys 2.5

Part no.	Product name
L-010-0734D	TPSys 2.0 software kit
L-010-0748B	TPSys 2.1 software kit
L-010-0795E	TPSys 2.2 software kit
L-010-0810D	TPSys 2.3.4 software kit
L-010-0849	TPSys 2.4 software kit
L-010-0868	TPSys 2.5 software kit



## Spare Part Set 1F TP9-1/TP9-2

**Type of part:**  
Kit

### Description

This spare part set is for machines with older design of electronics.

5 x Tool adapter A12, Peek (D-012-0263D-4)  
 2 x Steel belt with hole for centering (D-012-0276-4)  
 2 x Steel belt no hole for centering (D-012-0278-4)  
 10 x Reference point sticker 1\*5 (D-014-0819-4)  
 1 x Photo detector IR (E-040-0030)  
 1 x Photo diode IR (E-040-0031)  
 2 x Lamp 12V 3W (SONY camera) (E-040-0102)  
 10 x Filter (K-012-0016)  
 1 x Hydraulic oil (L-012-0122)  
 1 x Grease paste (K-013-0014)  
 1 x Belt T2.5/145 B=3 (K-014-0022)  
 1 x Belt T2.5/317.5 B=4 (K-014-0024)  
 1 x Spare part set membrane pump (L-010-0708)  
 1 x Vacuum tube with Z sensor cable (L-012-0073B)  
 1 x MOT1 board (L-019-0029)  
 2 x XMIF-MAG TP9-Mag connector cable (L-019-0093B)  
 1 x XFM/XMM magazine motor (L-029-0507)  
 1 x Fuse set (L-019-0128)  
 1 x XFiM motor cable (L-019-0204C)  
 1 x XTC Centering jaws with cables (L-019-0490)  
 4 x Screw LKCS 3x4mm for Centering jaws (M-0442)  
 3 x Screw MCS 2x4mm for Steel belt (M-0667)  
 4 x O-ring 4.3x2.4mm for Tool body (M-0946)  
 4 x Stopscrew P6SS 2x3mm for cogwheels (M-0956)  
 2 x Hexagonal key 263, 0.9\*40 (M-1164)  
 3 x 74LS244 for MI-board (SH74LS244)  
 2 x 8x400mA 90V Darlington driver (SHL603)

### Machine type:

TP9-1, TP9-2

### Requirements:

Only for machines with Computer Box 1.

Part no.	Product name
L-010-0030F	Spare Part Set 1F TP9-1/TP9-2

## Spare Part Set 1 TP9-2U

**Type of part:**  
Kit

### Description

This spare part set is for machines with newer design of electronics.

5 x Tool adapter A12, Peek (D-012-0263D-4)  
 2 x Steel belt with hole for centering (D-012-0276-4)  
 2 x Steel belt no hole for centering (D-012-0278-4)  
 10 x Reference point sticker 1\*5 (D-014-0819-4)  
 1 x Photo detector IR (E-040-0030)  
 1 x Photo diode IR (E-040-0031)

2 x Lamp 12V 3W (SONY camera) (E-040-0102)  
 2 x Filter ZFF255 (K-011-0051)  
 10 x Filter (K-012-0016)  
 1 x Hydraulic oil (L-012-0122)  
 1 x Grease paste (K-013-0014)  
 1 x Belt T2.5/145 B=3 (K-014-0022)  
 1 x Belt T2.5/317.5 B=4 (K-014-0024)  
 1 x Spare part set membrane pump (L-010-0708)  
 1 x Vacuum tube with Z sensor cable (L-012-0073B)  
 2 x XMIF-MAG TP9-Mag connector cable (L-019-0093B)  
 1 x Power supply fuse set (L-019-1000)  
 1 x Booster fuse set (L-019-1002)  
 1 x BM3CB (L-019-1003)  
 1 x XFM/XMM magazine motor (L-029-0507)  
 1 x XFiM motor cable (L-019-0204C)  
 1 x XTC Centering jaws with cables (L-019-0490)  
 1 x MOT1 with front panel (L-019-0709)  
 4 x Screw LKCS 3x4mm for Centering jaws (M-0442)  
 3 x Screw MCS 2x4mm for Steel belt (M-0667)  
 4 x O-ring 4.3x2.4mm for Tool body (M-0946)  
 4 x Stopscrew P6SS 2x3mm for cogwheels (M-0956)  
 2 x Hexagonal key 263, 0.9\*40 (M-1164)  
 3 x 74LS244 for MI-board (SH74LS244)

### Machine type:

TP9-2

### Requirements:

Only for machines with Computer box 2.

Part no.	Product name
L-010-0361	Spare Part Set 1 TP9-2U

## Spare Part Set 1B TP9/11-UFP

**Type of part:**  
Kit

### Description

This spare part set is for machines with older design of electronics.

5 x Tool adapter A12 (D-012-0263B-4)  
 10 x Reference point sticker 1\*5 (D-014-0819-4)  
 2 x Steel belt C-60 with hole (D-022-0027-4)  
 4 x Steel belt C-60 without hole (D-022-0028B-3)  
 2 x Lamp 12V 3W (SONY camera) (E-040-0102)  
 10 x Filter (K-012-0016)  
 1 x Hydraulic oil (L-012-0122)  
 1 x Grease paste (K-013-0014)  
 1 x Belt T2.5\145 B=3 (K-014-0022)  
 1 x Belt T2.5\317.5 B=4 (K-014-0024)  
 1 x Spare part set membrane pump (L-010-0708)  
 2 x XMIF-MAG TP9-Mag connector cable (L-019-0093B)  
 1 x Fuse set (L-019-0487)  
 1 x MOT2 (L-029-0080)  
 1 x XTEM-XTEE C-60 electrodes with cable (L-029-0175B)  
 1 x XFMB cable (FMB-XWB2) (L-029-0193)  
 1 x XZI Z-sensor cable with tube (L-029-0199B)  
 4 x Screw LKCS 3x4mm for Centering jaws (M-0442)  
 3 x Screw MCS 2x4mm for Steel belt (M-0667)  
 4 x Oring 4.3x2.4mm for Tool body (M-0946)



4 x Stopscrew P6SS 2x3mm for cogwheels (M-0956)  
 2 x Hexagonal key 263, 0.9\*40 (M-1164)  
 2 x 74HC244 for MI-board (SH74HC244)  
 3 x 74LS244 for MI-board (SH74LS244)  
 2 x 8x400mA 90V Darlington driver (SHL603)

**Machine type:**

TP9-4 , TP11

**Requirements:**

Only for machines with Computer box 1.

Part no.	Product name
----------	--------------

L-010-0330B	Spare Part Set 1B TP9/11-UFP
-------------	------------------------------

**Spare Part Set 1 TP9/11-UFP****Type of part:**

Kit

**Description**

This spare part set is for machines with newer design of electronics.

5 x Tool adapter A12 (D-012-0263B-4)  
 10 x Reference point sticker 1\*5 (D-014-0819-4)  
 2 x Steel belt C-60 with hole (D-022-0027-4)  
 4 x Steel belt C-60 without hole (D-022-0028B-3)  
 2 x Lamp 12V 3W (SONY camera) (E-040-0102)  
 2 x Filter ZFF255 (K-011-0051)  
 10 x Filter (K-012-0016)  
 1 x Hydraulic oil (L-012-0122)  
 1 x Grease paste (K-013-0014)  
 1 x Belt T2.5\145 B=3 (K-014-0022)  
 1 x Belt T2.5\317.5 B=4 (K-014-0024)  
 1 x Spare part set membrane pump (L-010-0708)  
 1 x Grease dispenser with filter, X rail (L-015-0395)  
 1 x Grease dispenser with filter (L-015-0397)  
 2 x XMIF-MAG TP9-Mag connector cable (L-019-0093B)  
 1 x Power supply fuse set (L-019-1000)  
 1 x Booster fuse set (L-019-1002)  
 1 x BM3CB (L-019-1003)  
 1 x XFM/XMM - T-Mag. motor with cable (L-029-0507)  
 1 x XTEM-XTEE C-60 electrodes with cable (L-029-0175B)  
 1 x XFMB cable (FMB-XWB2) (L-029-0193)  
 1 x XZI Z-sensor cable with tube (L-029-0199B)  
 1 x MOT3 with front panel (L-049-0162)  
 4 x Screw LKCS 3x4mm for Centering jaws (M-0442)  
 3 x Screw MCS 2x4mm for Steel belt (M-0667)  
 4 x Oring 4.3x2.4mm for Tool body (M-0946)  
 4 x Stopscrew P6SS 2x3mm for cogwheels (M-0956)  
 2 x Hexagonal key 263, 0.9\*40 (M-1164)  
 3 x 74LS244 for MI-board (SH74LS244)

**Machine type:**

TP9-4 , TP11

**Requirements:**

Only for machines with Computer box 2.

Part no.	Product name
----------	--------------

L-010-0360	Spare Part Set 1 TP9/11-UFP
------------	-----------------------------

**Spare Part Set 1B TP12/18-UFP****Type of part:**

Kit

**Description**

This set is included in the Base Unit.

5 x Tool adapter A12 (D-012-0263B-4)  
 10 x Reference point sticker 1\*5 (D-014-0819-4)  
 2 x Steel belt C-60 with hole (D-022-0027-4)  
 4 x Steel belt C-60 without hole (D-022-0028B-3)  
 2 x Lamp 12V 3W (SONY camera) (E-040-0102)  
 10 x Filter (K-012-0016)  
 1 x Hydraulic oil (L-012-0122)  
 1 x Grease paste (K-013-0014)  
 1 x Belt T2.5\145 B=3 (K-014-0022)  
 1 x Belt T2.5\317.5 B=4 (K-014-0024)  
 1 x Spare part set membrane pump (L-010-0708)  
 2 x XMIF-MAG TP9-Mag connector cable (L-019-0093B)  
 1 x MOT3 with ejector (L-049-0008)  
 1 x XTEM-XTEE C-60 electrodes with cable (L-029-0175B)  
 1 x XFMB cable (FMB-XWB2) (L-029-0193)  
 1 x XZI Z-sensor cable with tube (L-029-0199B)  
 1 x Fuse set (L-029-0250)  
 4 x Screw LKCS 3x4mm for Centering jaws (M-0442)  
 3 x Screw MCS 2x4mm for Steel belt (M-0667)  
 4 x Oring 4.3x2.4mm for Tool body (M-0946)  
 4 x Stopscrew P6SS 2x3mm for cogwheels (M-0956)  
 2 x Hexagonal key 263, 0.9\*40 (M-1164)  
 3 x 74LS244 for MI-board (SH74LS244)  
 2 x 8x400mA 90V Darlington driver (SHL603)

**Machine type:**

TP12 , TP18

Part no.	Product name
----------	--------------

L-020-0030B	Spare Part Set 1B TP12/18-UFP
-------------	-------------------------------

**Spare Part Set 1 MY-Series****Type of part:**

Kit

**Part is replacing:**

L-040-0031

**Description**

This set is included in the base unit.

5 x Tool adapter A12 (D-012-0263D-4)  
 10 x Reference point sticker 1\*5 (D-014-0819-4)  
 2 x C60 Steel Belt with hole (D-022-0027-4)  
 4 x C60 Steel belt without hole (D-022-0028B-3)

2 x Lamp 12V 3W (SONY camera) (E-040-0102)  
 2 x Filter ZFF255 (K-011-0051)  
 10 x Filter (K-012-0016)  
 1 x Hydraulic oil for Fi and C, 100 ml (L-012-0122)  
 1 x Grease paste 100 g, X-belt (K-013-0014)  
 1 x Belt T2.5/145 B=3 (K-014-0022)  
 1 x Belt T2.5/317.5 B=4 (K-014-0024)  
 1 x Membrane pump (L-010-0709)  
 1 x Grease gun for X-rail (L-015-0395)  
 1 x Grease gun with filter for YWU (L-015-0397)  
 1 x Centering electrodes with cable (L-029-0175B)  
 1 x XFMB cable (FMB-XWB2) (L-029-0193)  
 1 x XZI Z-sensor cable with tube (L-029-0199B)  
 2 x XMIF2 Magazine connector cable 2 (L-049-0062)  
 1 x Fuse set MY 9/11/15/19 (L-049-0102B)  
 4 x Screw K6S 3\*6 A2 stainless (M-0346)  
 3 x screw MCS 2\*4 FZB (M-0667)  
 4 x O-ring 4.3\*2.4 (M-0946)  
 4 x Grub screw P6SS 2\*3 (M-0956)  
 1 x Hexagonal key 263, 0.9\*40 (M-1164)  
 2 x 74HC244 (SH74HC244)  
 3 x 74LS244 (SH74LS244)  
 4 x 8\*400mA 90V Darl. 2.7K series SGS-AT (SHL603)

### Machine type:

MY9, MY12, MY15, MY19

Part no.	Product name
L-040-0034	Spare Part Set 1 MY-Series

## Base spare part set MY generation I7

### Type of part:

Kit

### Machine type:

MY9, MY12, MY15, MY19

### Requirements:

For MY-series machines of generation I7 and later.

Part no.	Product name
L-040-0418	Base spare part set MY generation I7

## Spare part kit 1 MY with Midas

### Type of part:

Kit

### Description

Spare part kit for MY-machine equipped with Midas.

5 x Tool adapter A12, PEEK (D-012-0263D-4)  
 10 x Magazine reference sticker 1X5 (D-014-0819-4)  
 2 x Steel belt with hole for C60 (D-022-0027-4)  
 4 x Steel belt without hole for C60 (D-022-0028B-3)  
 2 x Lamp 12V, 3W (E-040-0102)  
 2 x Filter ZFF255 10-PCS (K-011-0051)

10 x Vacuum filter (K-012-0016)  
 1 x Hydraulic oil (L-012-0122)  
 1 x Grease paste (K-013-0014)  
 1 x Belt 2.5/145 B=3 (K-014-0022)  
 1 x Belt 2.5/317.5 B=4 (K-014-0024)  
 1 x Spare part kit tandem pump (L-010-0709)  
 1 x Grease gun for x-rail (L-015-0395)  
 1 x Grease gun with filter for YWU (L-015-0397)  
 1 x Centering electrodes for C-60 (L-029-0175B)  
 1 x XFMB cable (FMB-XWB2) (L-029-0193)  
 1 x FFX Flex board, Midas (L-029-0366-2)  
 450 mm Vacuum tube (K-022-0045)  
 2 x XMIF2 Magazine connector cable (L-049-0062)  
 1 x Fuse kit MY-series (L-049-0102B)  
 4 x Screw K6S 3\*6 10.9 steel FZS (M-0346)  
 3 x Screw MCS 2\*4 stainless A2-70 (M-0667)  
 4 x O-RING 4.3\*2.4 (M-0946)  
 4 x Set screw P6SS 2\*3 steel black (M-0956)  
 1 x Hexagonal key 263 0.9\*40 (M-1164)  
 2 x IC 74HC244 (SH74HC244)  
 3 x IC 74LS244 (SH74LS244)  
 4 x 8\*400MA 90V DARL 2.7K SERIE (SHL603)

### Machine type:

MY12, MY15, MY19, MY9

Part no.	Product name
L-040-0152	Spare part kit 1 MY with Midas

## Spare Part Set 2 MY with Midas

### Type of part:

Kit

### Description

Spare part kit for MY-machine equipped with Midas.

1m x Silicon tube 3.5\*8 (K-012-0030B)  
 1 x Vacuum valve(MAC) (K-012-0084)  
 1 x TC2 ed 2C excluding pals (L-019-0652-2C)  
 1 x WSR2 ed 3 (L-029-0036-3)  
 1 x Z-motor, Midas (L-022-0105B)  
 4 x Brushes (K-022-0042)  
 1 x Z-lock solenoid with cable (L-029-0191B)  
 1 x XWB3 ed 3B (L-029-0276-3B)  
 1 x Paib2 ed 3B (L-029-0310-3B)  
 1 x XFM/XMM Tape magazine motor (L-029-0507)  
 1 x MIBB ed 2 Magazine Interface Bus Board (L-049-0001-2)  
 1 x MOT3 with front panel (L-049-0162)  
 1 x MI-MOT3 unit with front panel (L-049-0185)

### Machine type:

MY12, MY15, MY19, MY9

Part no.	Product name
L-040-0153	Spare Part Set 2 MY with Midas



## TEX pallet barcode sticker



### Description

Kit with 16 bar code labels left and 16 bar code labels right for narrow pallets.

### Requirements:

TEX with Narrow Cassettes - L-024-0100.

Part no.	Product name
L-024-0178	TEX Bar codes 16 narrow pallet
L-024-0179	TEX Bar codes 16 wide pallet
L-024-0188	TEX Barcodes 16 Jedec pallet

## Belt T10/1700 B=10



Type of part:  
Belt

### Description

Tray Wagon Magazine belt.

### Machine type:

Magazine

### Requirements:

Tray Wagon Magazine.

Part no.	Product name
K-025-0007	Belt T10/1700 B=10

## Cogbelt TEX Shuttle Unit

### Type of part:

Belt

### Machine type:

Tray Exchanger

Part no.	Product name
K-024-0026	Cogbelt TEX Shuttle Unit

## Door switch with cable



Type of part:  
Cable

### Machine type:

Tray Elevator

### Requirements:

TPSys

Part no.	Product name
L-029-0189	Door switch with cable

## Load position sensor



Type of part:  
Cable

### Machine type:

Tray Elevator

### Requirements:

TPSys

Part no.	Product name
L-029-0126	Load position sensor

## Safety extension in / TEX

### Type of part:

Cable

### Machine type:

Tray Exchanger

Part no.	Product name
L-029-0397	Safety extension in / TEX

## Safety extension out / TEX

### Type of part:

Cable

### Machine type:

Tray Exchanger

Part no.	Product name
L-029-0398	Safety extension out / TEX

### Safety Loop Extension cable



Type of part:  
Cable

Machine type:  
Tray Exchanger

Part no.	Product name
L-029-0399	Safety Loop Extension cable

### Tray contact sensor with cable



Type of part:  
Cable

Machine type:  
Tray Elevator

Part no.	Product name
L-029-0123	Tray contact sensor with cable

### Tray holder magnet with cable

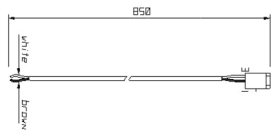

Type of part:  
Cable

Machine type:  
Tray Elevator

Requirements:  
TPSys

Part no.	Product name
L-029-0124	Tray holder magnet with cable

### Tray stop solenoids with cable

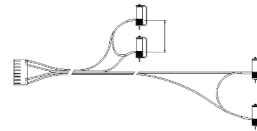

Type of part:  
Cable

Machine type:  
Tray Elevator

Part no.	Product name
L-029-0128	Tray stop solenoids with cable

### Unloading position sensor



Type of part:  
Cable

Machine type:  
Tray Elevator

Requirements:  
TPSys

Part no.	Product name
L-029-0127	Unloading position sensor

### XBOF Booster Power cable / TEX

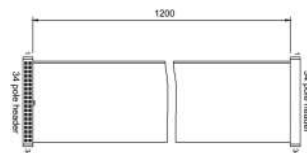

Type of part:  
Cable

Machine type:  
Tray Exchanger

Part no.	Product name
L-029-0379	XBOF Booster Power cable / TEX

## XBOP Booster Power cable

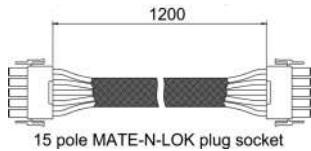

**Type of part:**  
Cable

**Machine type:**  
Tray Exchanger

Part no.	Product name
L-029-0380	XBOP Booster Power cable

## XCP Crude Power cable

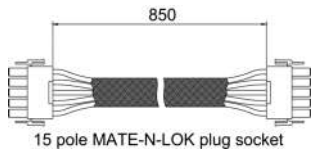

**Type of part:**  
Cable

**Machine type:**  
Tray Exchanger

Part no.	Product name
L-029-0381	XCP Crude Power cable

## XDSS Door Safety Switch cable

**Type of part:**  
Cable

**Part is replacing:**  
L-029-0383

**Machine type:**  
Tray Exchanger

Part no.	Product name
L-029-0383B	XDSS Door Safety Switch cable

## XLED cable / TEX

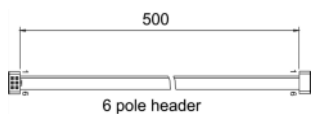

**Type of part:**  
Cable

**Machine type:**  
Tray Exchanger

Part no.	Product name
L-029-0391	XLED cable / TEX

## XM XO-X6 cable

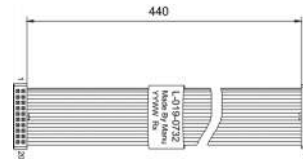

**Type of part:**  
Cable

**Machine type:**  
MY12 , MY15 , MY19 , MY9 , TP11 , TP9-2 , TP9-4 , Tray Exchanger

Part no.	Product name
L-019-0732	XM XO-X6 cable

## XSP safety sensor and switch



**Type of part:**  
Cable

**Machine type:**  
Tray Elevator

**Requirements:**  
TPSys

Part no.	Product name
L-029-0164	XSP safety sensor and switch

## XTY-Z TEX Y Wagon Z-unit cable

**Type of part:**  
Cable

**Machine type:**  
Tray Exchanger

Part no.	Product name
L-029-0388	XTY-Z TEX Y Wagon Z-unit cable



**Machine type:**  
Tray Exchanger

Part no.	Product name
D-024-0148-3	Cog wheel, TEX Mother Unit

**D9FTE DSUB-9 F mod. 6/6 straight**

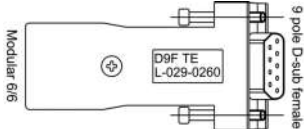

**Type of part:**  
Electrical component

**Description**  
Adapter to convert RS232 modular 6/6 to DSUB 9 pole female. Only to be used with Tray Elevator.

**Machine type:**  
Tray Elevator

**Requirements:**  
TPSys

Part no.	Product name
L-029-0260	D9FTE DSUB-9 F mod. 6/6 straight

**Inductive encoder / TEX**



**Type of part:**  
Electrical component

**Machine type:**  
Tray Exchanger

Part no.	Product name
L-029-0386	Inductive encoder / TEX

**Jumper / TEX**

**Type of part:**  
Electrical component

**Machine type:**  
Tray Exchanger

Part no.	Product name
L-029-0417	Jumper / TEX

**MY 105B TE serial number PAL**



**Type of part:**  
Electrical component

**Description**  
Tray Elevator serial number PAL.

**Machine type:**  
Tray Elevator

**Requirements:**  
TPSys

Part no.	Product name
L-019-0420A	MY 105B TE serial number PAL

**MY 134A MOT2 boot PROM**

**Type of part:**  
Electrical component

**Description**  
For using a standard MOT2 on a Tray Elevator. Note that the MOT2 has to be edition 3.

**Machine type:**  
Tray Elevator

**Requirements:**  
TPSys

Part no.	Product name
L-029-0240	MY 134A MOT2 boot PROM

**Power Relay with cables / TEX**

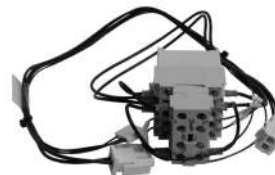

**Type of part:**  
Electrical component

**Machine type:**  
Tray Exchanger

Part no.	Product name
L-029-0416	Power Relay with cables / TEX



### RCYMT TEX RC-unit to Y-motor

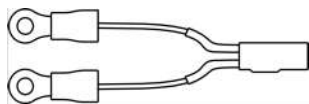

**Type of part:**  
Electrical component

**Machine type:**  
Tray Exchanger

Part no.	Product name
L-029-0385	RCYMT TEX RC-unit to Y-motor

### Safety Loop Extension end plug



**Type of part:**  
Electrical component

**Machine type:**  
Tray Exchanger

Part no.	Product name
L-029-0400	Safety Loop Extension end plug

### Safety switch for Y-wagon hood and TEX. Not for Pro-Line hoods.

**Type of part:**  
Electrical component

**Part is replacing:**  
K-024-0017

**Machine type:**  
MY12 , MY15 , MY19 , MY9 , TP11 , TP9-4 , Tray Exchanger

Part no.	Product name
L-024-0182	Safety switch for Y-wagon hood and TEX. Not for Pro-Line hoods.

### X24C02P DIL-8

**Type of part:**  
Electrical component

**Machine type:**  
Tray Exchanger

Part no.	Product name
SHX24C02	X24C02P DIL-8

### Bearing housing Y Wagon



**Type of part:**  
Mechanical component

#### Description

Four pieces in each Y Wagon Unit.  
Two pieces in each Tray wagon magazine.

#### Machine type:

TP9-1 , TP9-2 , TP9-3 , TP9-4 , TP11 , TP12 , TP18 , Magazine

#### Requirements:

YWU1, YWU2 or Tray wagon magazine

Part no.	Product name
K-015-0028-R	Bearing housing Y Wagon

### Flexible joint 8/8



**Type of part:**  
Mechanical component

#### Description

For Z-movement on Tray Elevator.

#### Machine type:

Tray Elevator

#### Requirements:

TPSys

Part no.	Product name
K-024-0015	Flexible joint 8/8

**Flexible joint (3x4) TE**



**Type of part:**  
Mechanical component

**Machine type:**  
Tray Elevator

**Requirements:**  
TPSys

Part no.	Product name
K-022-0024	Flexible joint (3x4) TE

**Locking screw**



**Type of part:**  
Mechanical component

**Description**  
For locking Tray Wagon Magazine.

**Machine type:**  
Magazine

**Requirements:**  
TPSys

Part no.	Product name
L-025-0078	Locking screw

**Rack, TEX Mother Unit**



**Type of part:**  
Mechanical component

**Machine type:**  
Tray Exchanger

Part no.	Product name
D-024-0160-3	Rack, TEX Mother Unit

**Rail guide, TEX Mother Unit**



**Type of part:**  
Mechanical component

**Machine type:**  
Tray Exchanger

Part no.	Product name
K-024-0034	Rail guide, TEX Mother Unit

**Runner 6\*19**



**Type of part:**  
Mechanical component

**Machine type:**  
Tray Exchanger

Part no.	Product name
K-024-0032	Runner 6*19

**Shuttle, TEX Shuttle Unit**



**Type of part:**  
Mechanical component

**Machine type:**  
Tray Exchanger

Part no.	Product name
L-024-0108	Shuttle, TEX Shuttle Unit

**Slide strip, TEX**

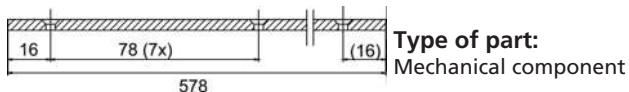

**Type of part:**  
Mechanical component

**Machine type:**  
Tray Exchanger

Part no.	Product name
D-024-0118-3	Slide strip, TEX

**Glide list**



**Type of part:**  
Miscellaneous

**Description**  
Teflon tape for Tray Wagon Magazine. 1345 mm long.

**Machine type:**  
Magazine

Part no.	Product name
L-025-0042	Glide list

**Motor for lead screw Y Wagon**



**Type of part:**  
Motor  
**Part is replacing:**  
L-019-0012

**Machine type:**  
TP11 , TP12 , TP18 , TP9-1 , TP9-2 , TP9-3 , TP9-4

**Requirements:**  
Y Wagon Unit - YWU1, YWU2 or Tray Wagon Magazine.

Part no.	Product name
L-019-0012B	Motor for lead screw Y Wagon

**Motor TEX Mother Unit**



**Type of part:**  
Motor

**Machine type:**  
Tray Exchanger

Part no.	Product name
L-024-0121	Motor TEX Mother Unit

**Motor, TEX Shuttle Unit**



**Type of part:**  
Motor

**Machine type:**  
Tray Exchanger

Part no.	Product name
L-024-0106	Motor, TEX Shuttle Unit

**Z-Motor with cable for TE**



**Type of part:**  
Motor

**Machine type:**  
Tray Elevator

**Requirements:**  
TPSys

Part no.	Product name
L-029-0166	Z-Motor with cable for TE

**DCRB regulator board**

**Type of part:**  
PCB

**Machine type:**  
Tray Elevator

**Requirements:**  
TPSys

Part no.	Product name
L-029-0087-2B	DCRB regulator board

**EBM**

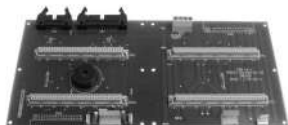

**Type of part:**  
PCB

**Machine type:**  
Tray Elevator

**Requirements:**  
TPSys

Part no.	Product name
L-019-0381-1	EBM

**EWB tray elevator board**

**Type of part:**  
PCB

**Machine type:**  
Tray Elevator

**Requirements:**  
TPSys

Part no.	Product name
L-029-0119-2	EWB tray elevator board

**MOT2 board for tray elevator**



**Type of part:**  
PCB

**Machine type:**  
Tray Elevator

**Requirements:**  
TPSys

Part no.	Product name
L-029-0272-3	MOT2 board for tray elevator

**Power supply**



**Type of part:**  
PCB

**Machine type:**  
Tray Elevator

**Requirements:**  
TPSys

Part no.	Product name
L-029-0113-2	Power supply

**TBB tray box board**



**Type of part:**  
PCB

**Machine type:**  
Tray Elevator

**Requirements:**  
TPSys

Part no.	Product name
L-019-0421-1	TBB tray box board

**TEXBMCB, TEX BM Con. board**



**Type of part:**  
PCB

**Machine type:**  
Tray Exchanger

Part no.	Product name
L-029-0319-3	TEXBMCB, TEX BM Con. board

### TEXLB, TEX LED Board



Type of part:  
PCB

Machine type:  
Tray Exchanger

Part no.	Product name
L-029-0334-2	TEXLB, TEX LED Board

### TEXYB, TEX Y Board

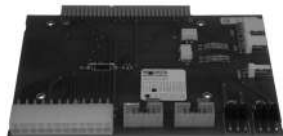

Type of part:  
PCB

Description  
Board in the TEX Y-unit.

Machine type:  
Tray Exchanger

Part no.	Product name
L-029-0335-3	TEXYB, TEX Y Board

### TEXZB, TEX Z Board



Type of part:  
PCB

Part is replacing:  
L-029-0323-3

Machine type:  
Tray Exchanger

Part no.	Product name
L-029-0323-3B	TEXZB, TEX Z Board

### THS with holder

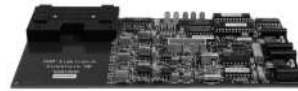

Type of part:  
PCB

Machine type:  
Tray Elevator

Requirements:  
TPSys

Part no.	Product name
L-024-0028	THS with holder

### Bearing housing, TEX Shuttle

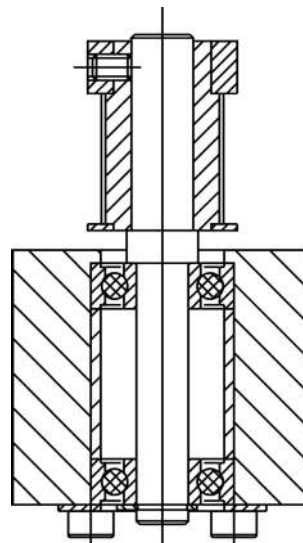

Type of part:  
Unit

Machine type:  
Tray Exchanger

Part no.	Product name
L-024-0103	Bearing housing, TEX Shuttle

**Belt pulley TWM**

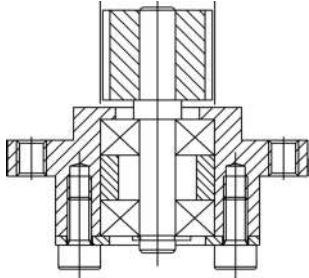

**Type of part:**  
Unit

**Description**  
For Tray Wagon Magazine.

**Machine type:**  
Magazine

**Requirements:**  
TPSys

Part no.	Product name
L-025-0002	Belt pulley TWM

**Flywheel TWM**



**Type of part:**  
Unit

**Description**  
For Tray Wagon Magazine.

**Machine type:**  
Magazine

**Requirements:**  
TPSys

Part no.	Product name
L-025-0036	Flywheel TWM

**Laser bar code reader**



**Type of part:**  
Unit

**Description**  
Bar code reader for Tray Exchanger. See Requirement before ordering.

**Machine type:**  
Tray Exchanger

**Requirements:**  
Tray Exchanger (TEX) with serial number 195 and lower needs to be upgraded with laser bar code reader before using this spare part. See upgrade kit - L-024-0180. Bar code reader - L-029-0393 no longer available.

Part no.	Product name
L-029-0548	Laser bar code reader

**Support plate**



**Type of part:**  
Unit

**Description**  
For Tray Wagon Magazine

**Machine type:**  
Magazine

**Requirements:**  
TPSys

Part no.	Product name
L-025-0040B	Support plate



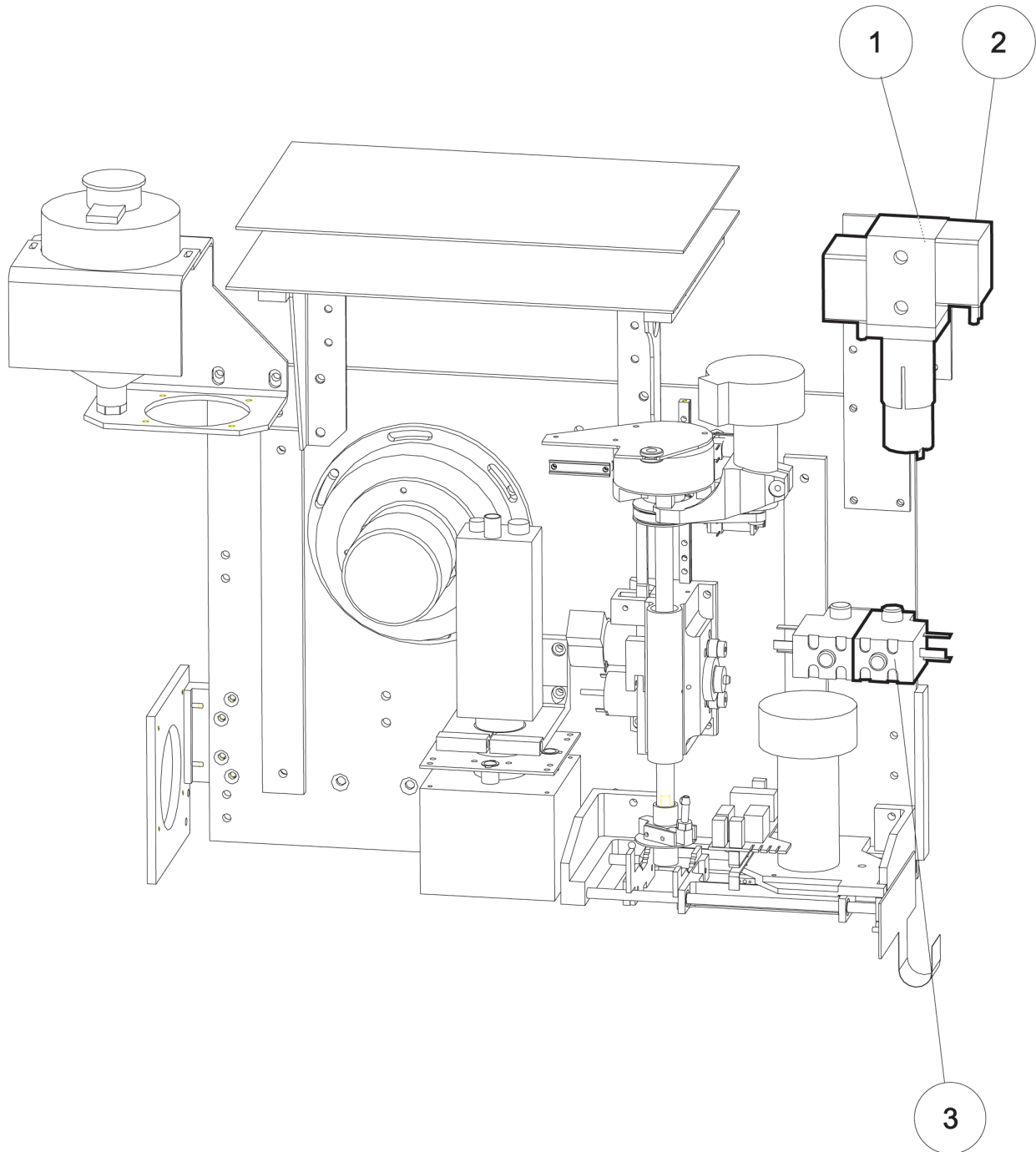



## Isolator



Position: 1

Type of part:  
Miscellaneous

### Description

Three pieces for each membrane pump.  
Eight pieces for each tandem pump.

### Machine type:

MY12, MY15, MY19, MY9, TP11, TP12, TP18, TP9-1, TP9-2, TP9-3, TP9-4

Part no.	Product name
K-012-0058	Isolator

## Vacuum valve (MAC)



Position: 3

Type of part:  
Electrical component

### Machine type:

MY12, MY15, MY19, MY9, TP11, TP12, TP18, TP9-1, TP9-2, TP9-3, TP9-4

### Requirements:

Use upgrade kit L-012-0370 when replacing the older version valve (K-012-0005).

Part no.	Product name
K-012-0084	Vacuum valve (MAC)

## Membrane pump complete



Position: 2

Type of part:  
Miscellaneous

### Description

For non-HYDRA TP-machines. For HYDRA TP machines and MY series see L-019-0714.

### Machine type:

TP11, TP12, TP18, TP9-1, TP9-2, TP9-3, TP9-4

Part no.	Product name
L-019-0279	Membrane pump complete

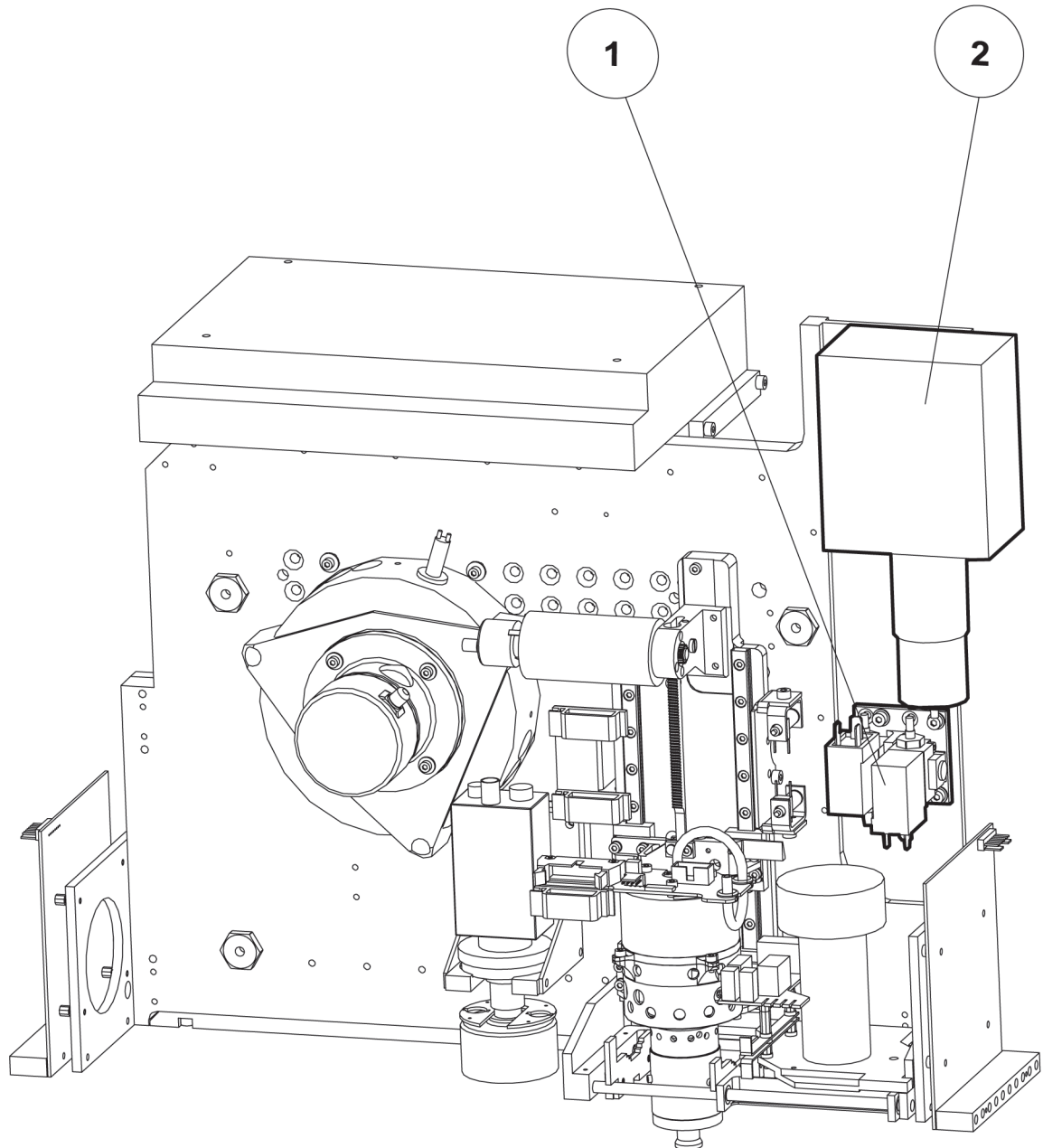

### Upgrade kit vacuum valve



**Position:** 1

**Type of part:**  
Update kit

**Part is replacing:**  
K-012-0005

**Description**

Upgrade to MAC valve.  
When upgraded use K-012-0084 when ordering new valves.

**Machine type:**

TP9-1 , TP9-2 , TP9-3 , TP9-4 , TP11 , TP12 , TP18

Part no.	Product name
L-012-0370	Upgrade kit vacuum valve

### Tandem vacuum pump



**Position:** 2

**Type of part:**  
Unit

**Machine type:**

MY12 , MY15 , MY19 , MY9 , TP11 , TP9-4

**Requirements:**

Only for TP9-4 and TP11 with HYDRA or MY-Series machines.

Part no.	Product name
L-019-0714	Tandem vacuum pump

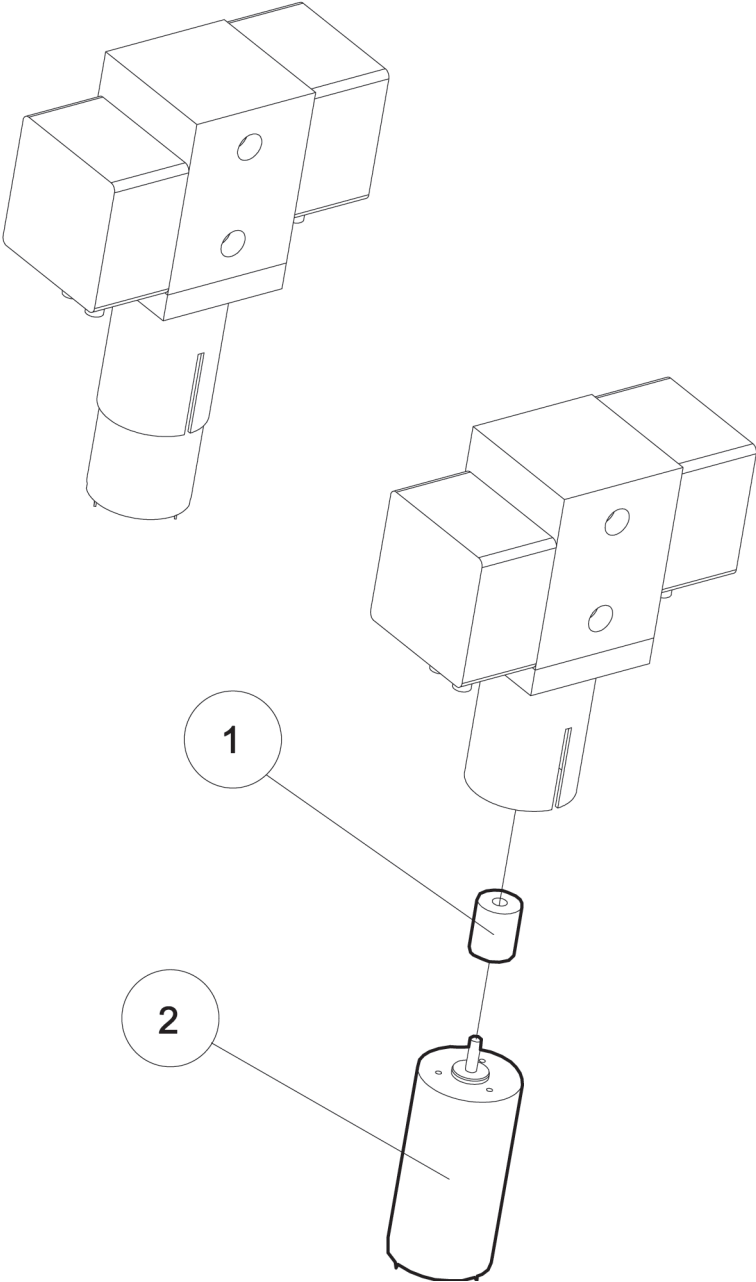

### Disc Oldham coupling



**Position:** 1

**Type of part:**  
Miscellaneous

**Part is replacing:**  
K-019-0305

**Machine type:**

MY12 , MY15 , MY19 , MY9 , TP11 , TP9-4

Part no.	Product name
K-019-0360	Disc Oldham coupling

### Disc Oldham coupling



**Position:** 1

**Type of part:**  
Miscellaneous

**Description**

Black wearable plastic disc

**Machine type:**

TP11 , TP12 , TP18 , TP9-1 , TP9-2 , TP9-3 , TP9-4

**Requirements:**

Only for non-HYDRA TP-machines.

Part no.	Product name
K-019-0022	Disc Oldham coupling

### Motor membrane pump



**Position:** 2

**Type of part:**  
Motor

**Machine type:**

TP9-1 , TP9-2 , TP9-3 , TP9-4 , TP11 , TP12 , TP18

**Requirements:**

Membrane pump - L-019-0279.

Part no.	Product name
L-019-0555	Motor membrane pump

### XVS vacuum system cable



**Type of part:**  
Cable

**Machine type:**

MY12 , MY15 , MY19 , MY9 , TP11 , TP12 , TP18 , TP9-3 , TP9-4

Part no.	Product name
L-029-0195C	XVS vacuum system cable

### Pump motor with cables



**Position:** 2

**Type of part:**  
Motor

**Machine type:**

MY12 , MY15 , MY19 , MY9 , TP11 , TP9-4

**Requirements:**

Tandem vacuum pump - L-019-0714.

Part no.	Product name
L-019-0713	Pump motor with cables

### XVS vacuum system cable

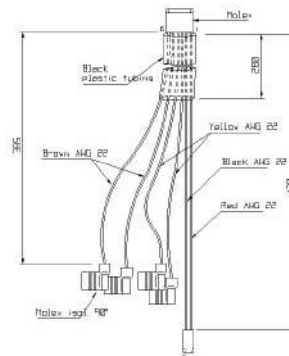

**Type of part:**  
Cable

**Machine type:**

TP9-1 , TP9-2

Part no.	Product name
L-019-0275D	XVS vacuum system cable

## Spare part kit Membrane Pump



**Type of part:**  
Kit

**Description**

Kit for refurbishing membrane pump.

Includes.

- One set of membranes, gaskets and valves. (K-019-0224)
- One coupling between motor and pump. (K-019-0017)
- Three isolators between pump and X Wagon. (K-012-0058)

**Machine type:**

TP9-1 , TP9-2 , TP9-3 , TP9-4 , TP11 , TP12 , TP18

**Requirements:**

Membrane pump - L-019-0279.

Part no.	Product name
L-010-0708	Spare part kit Membrane Pump

## Spare part kit Tandem Pump



**Type of part:**  
Kit

**Description**

Kit for refurbishing tandem pump.

Includes.

- One set of membranes, gaskets and valves. (L-012-0501)
- One disc for coupling between motor and pump. (K-019-0360)
- Eight isolators between pump and X Wagon. (K-012-0058)

**Machine type:**

TP9-4 , TP11 , MY9 , MY12 , MY15 , MY19

**Requirements:**

Tandem Pump - L-019-0714

Part no.	Product name
L-010-0709	Spare part kit Tandem Pump

## Vacuum filters and tubes



**Type of part:**  
Kit

**Machine type:**

MY12 , MY15 , MY19 , MY9 , TP11 , TP12 , TP18 , TP9-1 , TP9-2 , TP9-3 , TP9-4

**Requirements:**

Membrane pump.

Part no.	Product name
L-012-0104	Vacuum filters and tubes

## Holder for vacuum filter



**Type of part:**  
Mechanical component

**Part is replacing:**  
K-012-0045

**Description**

Used together with K-012-0016 and two pcs K-012-0024 to replace K-012-0045.

**Machine type:**

MY12 , MY15 , MY19 , MY9 , TP11 , TP12 , TP18 , TP9-1 , TP9-2 , TP9-3 , TP9-4

Part no.	Product name
K-012-0015	Holder for vacuum filter

### Membrane for pump, 5002, 12VDC



**Type of part:**  
Mechanical component

**Machine type:**  
TP9-1

**Requirements:**  
Membrane pump 5002 12V DC.

Part no.	Product name
K-012-0009	Membrane for pump, 5002, 12VDC

### Pressure tank



**Type of part:**  
Mechanical component

**Machine type:**  
MY12, MY15, MY19, MY9, TP11, TP12, TP18, TP9-1, TP9-2, TP9-3, TP9-4

Part no.	Product name
K-012-0028	Pressure tank

### Nipple, straight



**Type of part:**  
Mechanical component

**Part is replacing:**  
K-012-0045

**Description**  
Use two pieces together with K-012-0015 and K-012-0016 to replace K-012-0045.

**Machine type:**  
MY12, MY15, MY19, MY9, TP11, TP12, TP18, TP9-1, TP9-2, TP9-3, TP9-4

Part no.	Product name
K-012-0024	Nipple, straight

### Tube connector, T-230-1



**Type of part:**  
Mechanical component

**Machine type:**  
TP9-1, TP9-2, TP9-3, TP9-4, TP11, TP12, TP18

Part no.	Product name
K-012-0019	Tube connector, T-230-1

### Tube connector, T-40-1



**Type of part:**  
Mechanical component

**Machine type:**  
MY12, MY15, MY19, MY9, TP11, TP12, TP18, TP9-1, TP9-2, TP9-3, TP9-4

Part no.	Product name
K-012-0018	Tube connector, T-40-1

## Vacuum filter

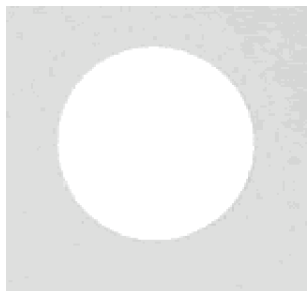

**Type of part:**  
Mechanical component

**Part is replacing:**  
K-012-0045

### Description

Used together with K-012-0015 and two K-012-0024 to replace K-012-0045.

### Machine type:

MY12, MY15, MY19, MY9, TP11, TP12, TP18, TP9-1, TP9-2, TP9-3, TP9-4

Part no.	Product name
K-012-0016	Vacuum filter

## Vacuum tank



**Type of part:**  
Mechanical component

### Machine type:

MY12, MY15, MY19, MY9, TP11, TP12, TP18, TP9-1, TP9-2, TP9-3, TP9-4

Part no.	Product name
K-012-0031	Vacuum tank

## Pressure reducing valve



**Type of part:**  
Miscellaneous

### Machine type:

TP9-1, TP9-2, TP9-3, TP9-4, TP11, TP12, TP18

Part no.	Product name
L-012-0099	Pressure reducing valve

## Silicon tube 3.5x8



**Type of part:**  
Miscellaneous

### Description

Silicon tube for vacuum system.

### Machine type:

MY12, MY15, MY19, MY9, TP11, TP12, TP18, TP9-1, TP9-2, TP9-3, TP9-4

### Ordering info:

Sold per meter.

Part no.	Product name
K-012-0030B	Silicon tube 3.5x8

## Upgrade for membrane pump



**Type of part:**  
Unit

### Machine type:

TP9-3, TP9-4, TP11

Part no.	Product name
L-012-0101	Upgrade for membrane pump

## Upgrade for membrane pump



**Type of part:**  
Update kit



**Machine type:**

TP9-1 , TP9-2

**Part no.**

**Product name**

Part no.	Product name
L-012-0100	Upgrade for membrane pump

**LED Cable**



Type of part:  
Cable

Machine type:  
MY12 , MY15 , MY19 , MY9

Requirements:  
Linescan Vision System.

Part no.	Product name
L-049-0202	LED Cable

**LSAD-LSPW LED control cable**



Type of part:  
Cable

Machine type:  
MY12 , MY15 , MY19 , MY9

Requirements:  
Linescan Vision System.

Part no.	Product name
L-019-0870	LSAD-LSPW LED control cable

**LSAD-LSS Multi video cable**



Type of part:  
Cable

Machine type:  
MY12 , MY15 , MY19 , MY9

Requirements:  
Linescan Vision System.

Part no.	Product name
L-019-0868	LSAD-LSS Multi video cable

**LSAD-VVG2 & LSAD-LSAD cable**



Type of part:  
Cable

Description:  
50 pole flat cable

Machine type:  
MY12 , MY15 , MY19 , MY9

Requirements:  
AT-CPU2 with CP5 for Linescan

Part no.	Product name
L-019-0940	LSAD-VVG2 & LSAD-LSAD cable

**LSPW-LSS power cable**



Type of part:  
Cable

Machine type:  
MY12 , MY15 , MY19 , MY9

Requirements:  
Linescan Vision System.

Part no.	Product name
L-019-0869	LSPW-LSS power cable

### XCLP cent. lamp power cable

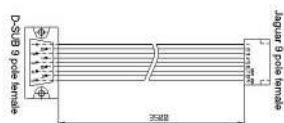

**Type of part:**  
Cable

**Machine type:**  
TP9-2

**Requirements:**  
PC-vision

Part no.	Product name
L-019-0441	XCLP cent. lamp power cable

### XV4L lamp cable



**Type of part:**  
Cable

**Part is replacing:**  
L-019-0303-1

**Machine type:**  
TP9-1 , TP9-2

**Requirements:**  
SONY Camera

Part no.	Product name
L-019-0303B	XV4L lamp cable

### XV4L video lamp cable

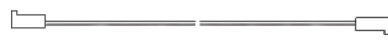

**Type of part:**  
Cable

**Description**  
Cable from Positioning Video Camera to XWB(x) board.

**Machine type:**  
TP9-3 , TP12 , TP18

Part no.	Product name
L-029-0194	XV4L video lamp cable

### Video camera, CCD XC-77BBCE



**Type of part:**  
Electrical component

**Description**  
Camera Sony CCD XC-77BBCE, for OVS optical centering camera.

**Machine type:**  
TP9-3 , TP9-4 , TP11 , TP12 , TP18

Part no.	Product name
K-019-0170B	Video camera, CCD XC-77BBCE

### LVS calibration component kit

**Type of part:**  
Kit

**Machine type:**  
MY9 , MY12 , MY15 , MY19

**Requirements:**  
TPSys 2.5

Part no.	Product name
L-040-1084	LVS calibration component kit

### Diffusor pyramid optical cent.



**Type of part:**  
Mechanical component

**Description**  
White plastic film diffusor for OVS camera.

**Machine type:**  
TP12 , TP18

Part no.	Product name
D-021-0223-4	Diffusor pyramid optical cent.

### Gauge - Line Scan Camera



**Type of part:**  
Mechanical component

**Machine type:**  
MY12 , MY15 , MY19 , MY9

Part no.	Product name
L-010-0422	Gauge - Line Scan Camera

### Lens Eritec 1.3/8mm



**Type of part:**  
Mechanical component

**Description**  
Optical centering camera lens.

**Machine type:**  
TP11 , TP12 , TP18 , TP9-1 , TP9-2 , TP9-3 , TP9-4

**Requirements:**  
OVS - Original Vision System.

Part no.	Product name
K-011-0018	Lens Eritec 1.3/8mm

### Linear encoder codestrip



**Type of part:**  
Mechanical component

**Machine type:**  
MY12 , MY15 , MY19 , MY9

**Requirements:**  
Linescan Vision System.

Part no.	Product name
L-010-0421	Linear encoder codestrip

### LVS reference background, C60



**Type of part:**  
Mechanical component

**Machine type:**  
MY12 , MY15 , MY19 , MY9

**Requirements:**  
Linescan Vision System.

Part no.	Product name
L-010-0428	LVS reference background, C60

### Optical centering shadow frame



**Type of part:**  
Mechanical component

**Description**  
Cover for OVC.

**Machine type:**  
TP9-1 , TP9-2

Part no.	Product name
D-011-0158C-3	Optical centering shadow frame

### Ruler with reference line

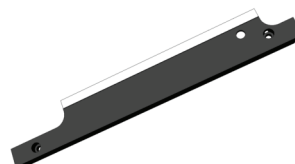

**Type of part:**  
Mechanical component

**Machine type:**  
MY9 , MY12 , MY15 , MY19

**Requirements:**  
Linescan camera

Part no.	Product name
L-010-0806	Ruler with reference line

### Window holder



**Type of part:**  
Mechanical component

**Machine type:**  
MY12 , MY15 , MY19 , MY9

**Requirements:**  
Linescan Vision System.

Part no.	Product name
L-010-0425	Window holder

### HLB HYDRA LED board

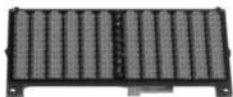

**Type of part:**  
PCB

**Description**  
This board is filled with LEDs that gives the light in the HYDRA camera. Two HLB boards together with a HLCC board makes up the HYDRA lightning box.

**Machine type:**  
MY12 , MY15 , MY19 , MY9 , TP11 , TP9-4

**Requirements:**  
HYDRA

Part no.	Product name
L-019-0813-2	HLB HYDRA LED board

### HLCC HYDRA LED & Camera cntrl



**Type of part:**  
PCB

**Description**  
This board controls the HYDRA camera and HYDRA lightning (HLB board). Two HLB boards together with a HLCC board makes up the HYDRA lightning box.

**Machine type:**  
MY12 , MY15 , MY19 , MY9 , TP11 , TP9-4

**Requirements:**  
HYDRA

Part no.	Product name
L-019-0812-3	HLCC HYDRA LED & Camera cntrl

### LSAD edition 2B

**Type of part:**  
PCB

**Part is replacing:**  
L-019-0837-1B

**Description**  
Linescan camera A/D-converter board. This board is part of the linescan camera system. It is placed next to VVG2 in the AT-CPU unit.

- It has the following functions:
- Analog video reception.
  - A/D-conversion.
  - Look-up-tables.
  - Linear encoder counter.
  - Line-sync generation.
  - LED control.

**Machine type:**  
MY9 , MY12 , MY15 , MY19

**Requirements:**  
Linescan Vision System.

Part no.	Product name
L-019-0837-2B	LSAD edition 2B

### LSLD Ed-2B Linescan LED board



**Type of part:**  
PCB

**Description**  
Linescan Camera LED board. Tapered illumination.

**Machine type:**  
MY12 , MY15 , MY19 , MY9

**Requirements:**  
Linescan Vision System.

Part no.	Product name
L-019-0838-2B	LSLD Ed-2B Linescan LED board

**OCL optical centering board**

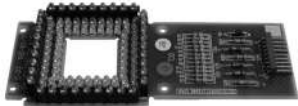

Type of part:  
PCB

Machine type:  
TP9-1 , TP9-2

Part no.	Product name
L-019-0291-3	OCL optical centering board

**OCL2 Optical centering board 2**



Type of part:  
PCB

Description  
Optical Centering LED board.

Machine type:  
TP9-3 , TP9-4 , TP11 , TP12 , TP18

Part no.	Product name
L-029-0122-2	OCL2 Optical centering board 2

**DVC Sparepart**

Type of part:  
Unit

Part is replacing:  
L-011-0040

Machine type:  
MY12 , MY15 , MY19 , MY9 , TP11 , TP12 , TP18 , TP9-4

Part no.	Product name
L-040-1076	DVC Sparepart

**Linear encoder head**



Type of part:  
Unit

Machine type:  
MY12 , MY15 , MY19 , MY9

Requirements:  
Linescan Vision System.

Part no.	Product name
L-010-0420	Linear encoder head

**Linescan Camera box**



Type of part:  
Unit

Machine type:  
MY12 , MY15 , MY19 , MY9

Requirements:  
Linescan Vision System.

Part no.	Product name
L-010-0450	Linescan Camera box

**LSC FL power supply spare part**

Type of part:  
Unit

Part is replacing:  
L-049-0193

Machine type:  
MY9 , MY12 , MY15 , MY19

Requirements:  
Linescan Vision System.

Part no.	Product name
L-049-0697	LSC FL power supply spare part

Part no.	Product name
L-049-0535-3B	OCLDM edition 3B

## OCLD edition 2

**Type of part:**  
Unit

**Part is replacing:**  
L-019-0804-2

**Description**  
This is the device supplying the light in the SVC, the Standard Vision Camera

**Machine type:**  
TP9-1 , TP9-2 , TP9-3 , TP9-4 , TP11 , TP12 , TP18 , MY9 , MY12 , MY15 , MY19

Part no.	Product name
L-019-0811-2	OCLD edition 2

## OCLDH edition 3B

**Type of part:**  
Unit

**Part is replacing:**  
L-049-0213-3B

**Description**  
Complete OCLDH unit in SVC and DVC cameras. This unit is used in cameras equipped with the Sony XC-73CE CCD which is less sensitive than the Sony XC-ST30CE.

**Machine type:**  
MY9 , MY12 , MY15 , MY19

Part no.	Product name
L-049-0218-3B	OCLDH edition 3B

## OCLDM edition 3B

**Type of part:**  
Unit

**Description**  
Complete OCLDH unit in SVC and DVC cameras. This unit is used in cameras equipped with the Sony XC-30CE CCD which is more sensitive than the Sony XC-ST73CE

**Machine type:**  
MY9 , MY12 , MY15 , MY19

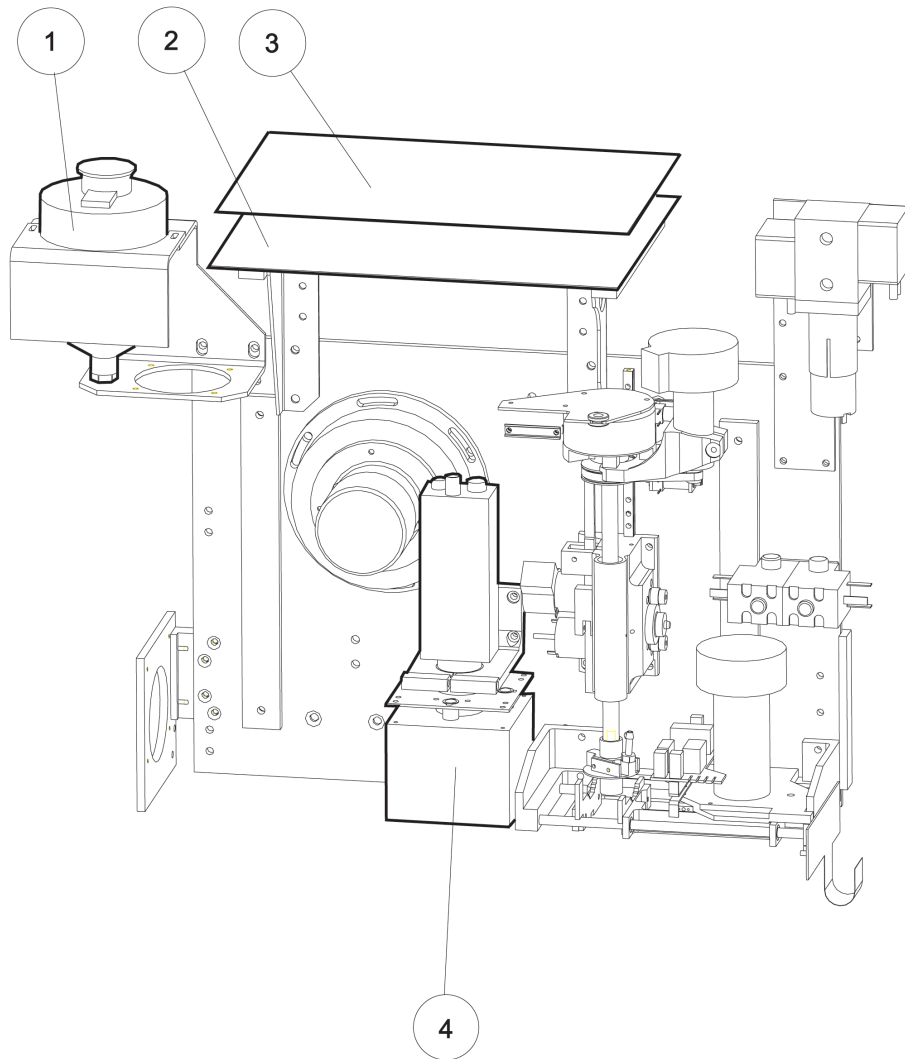



### Grease cartridge, cabled



**Position:** 1

**Type of part:**  
Miscellaneous

**Description**

Grease for lubricating x-rail.

**Machine type:**

TP11 , TP9-3 , TP9-4

Part no.	Product name
K-012-0055	Grease cartridge, cabled

### 3PT1, test circuit board



**Position:** 3

**Type of part:**  
PCB

**Part is replacing:**  
L-019-0037-3C

**Description**

This board tests components. It precision tests R and C and can also test various semiconductors.

**Machine type:**

MY12 , MY15 , MY19 , MY9 , TP11 , TP12 , TP18 , TP9-1 , TP9-2 , TP9-3 , TP9-4

Part no.	Product name
L-019-0037-3D	3PT1, test circuit board

### XWB3 X Wagon board 3

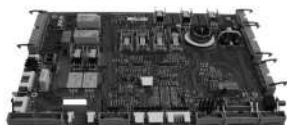

**Position:** 2

**Type of part:**  
PCB

**Part is replacing:**  
L-029-0276-2B

**Machine type:**

MY12 , MY15 , MY19 , MY9 , TP11 , TP12 , TP18 , TP9-1 , TP9-2 , TP9-3 , TP9-4

Part no.	Product name
L-029-0276-3B	XWB3 X Wagon board 3

### Upgrade X Wagon camera



**Position:** 4

**Type of part:**  
Update kit

**Machine type:**

TP9-1 , TP9-2 , TP9-3

Part no.	Product name
L-012-0074	Upgrade X Wagon camera

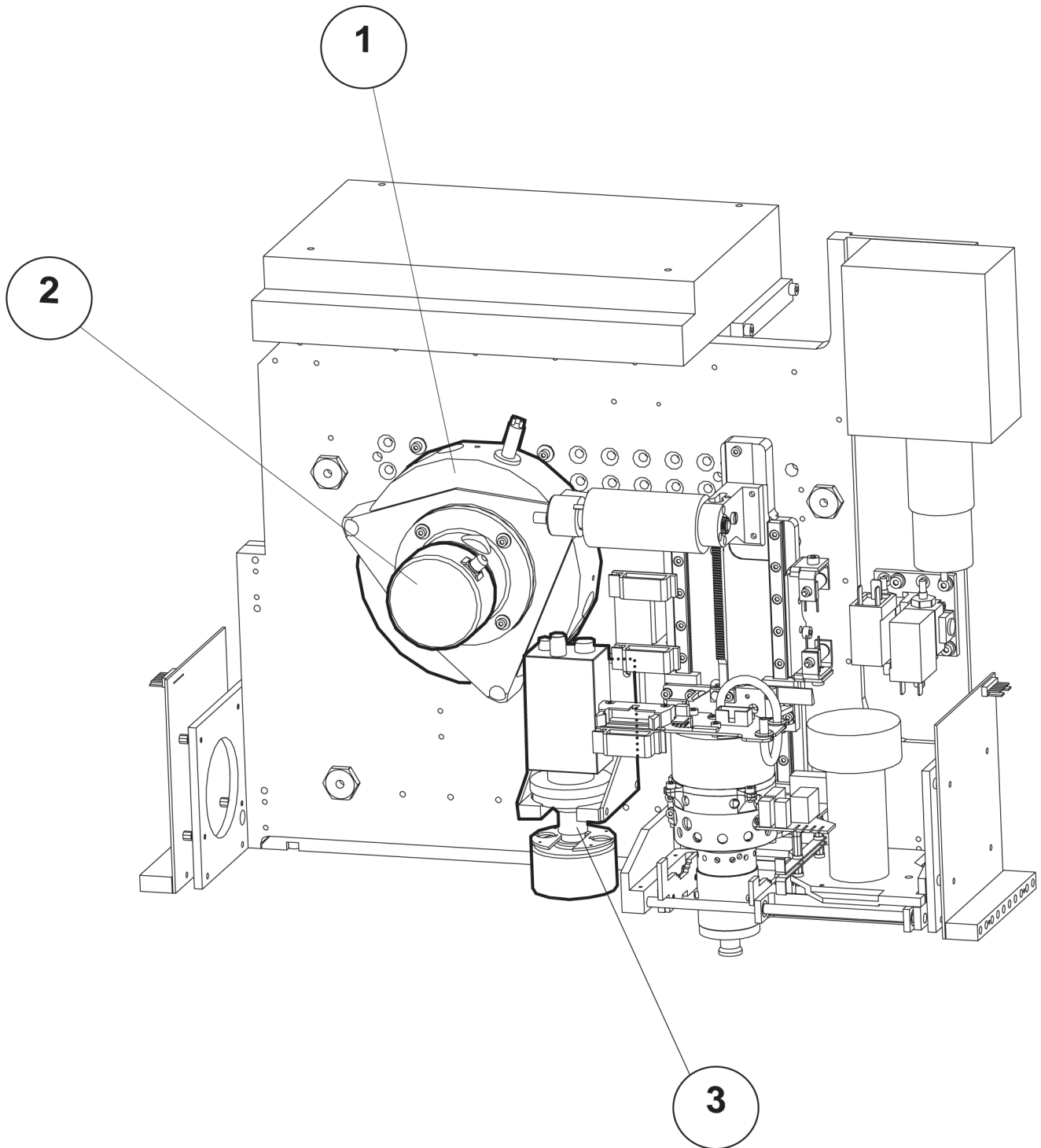

### X Wagon motor complete



**Position:** 1

**Type of part:**  
Motor

**Machine type:**  
MY9 , MY12 , MY15 , MY19

Part no.	Product name
L-049-0118	X Wagon motor complete

**Machine type:**

TP9-1 , TP9-2 , TP9-3 , TP9-4 , TP11 , TP12 , TP18 , MY9 , MY12 , MY15 , MY19

**Requirements:**

If replacing older versions of X-wagon camera a spacer (L-012-0326) is needed.

Part no.	Product name
L-012-0815	X-wagon camera spare part kit

### XXWT X Wagon transducer



**Position:** 2

**Type of part:**  
Electrical component

**Part is replacing:**  
L-029-0231

**Description**

For X Wagon motor. Resolution 6 um.

**Machine type:**

MY12 , MY15 , MY19 , MY9 , TP12 , TP18

Part no.	Product name
L-029-0231B	XXWT X Wagon transducer

### X-wagon camera spare part kit



**Type of part:**  
Unit

**Description**

X-wagon camera with Sony ES-30 camera and cable.

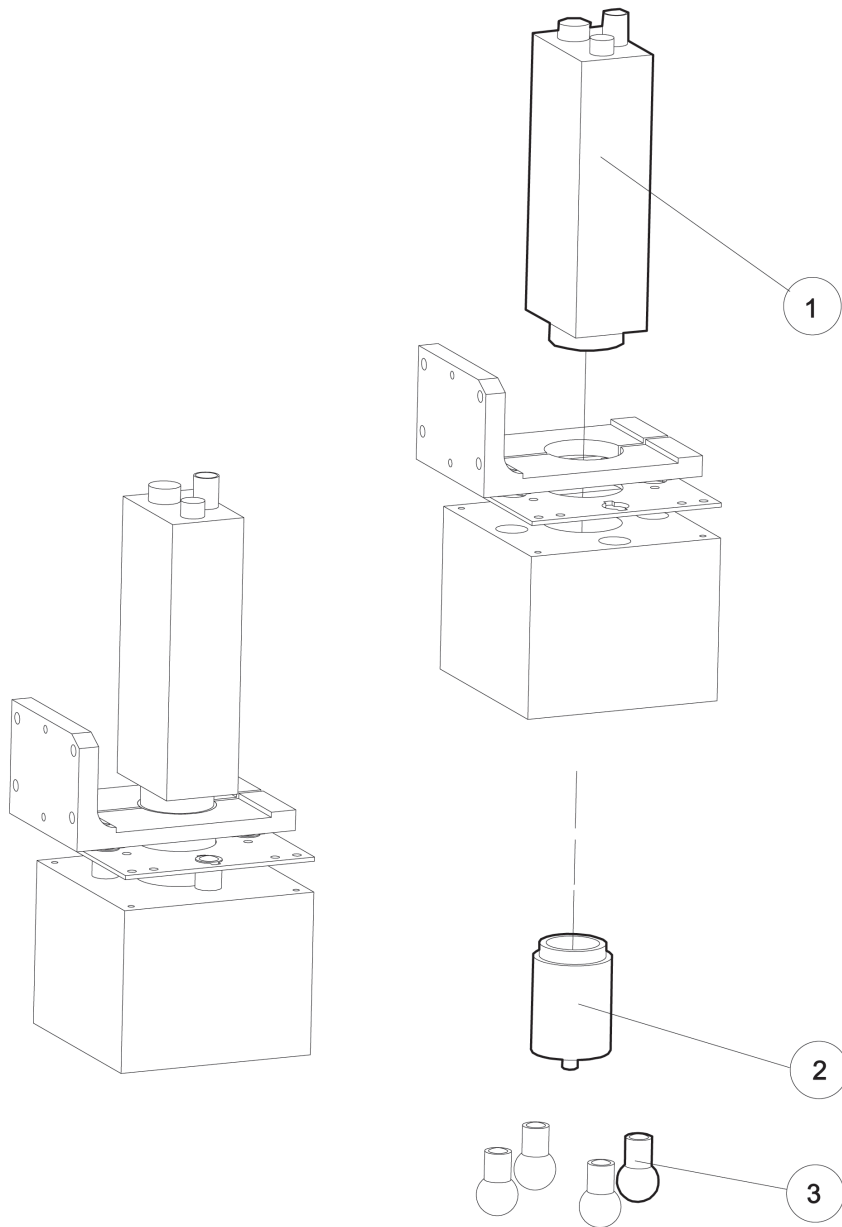

**Video camera, Sony CCD XC-77CE**



**Position:** 1  
**Type of part:**  
Electrical component

**Description**

Camera CCD XC-77CE.  
For X camera on TP9-1, TP9-2, TP9-3, TP9-4, TP11, TP12, TP18.  
Optical centering camera on OVC for TP9-1 or TP9-2.

**Machine type:**

TP9-1 , TP9-2 , TP9-3 , TP9-4 , TP11 , TP12 , TP18

Part no.	Product name
K-019-0170	Video camera, Sony CCD XC-77CE

**Lens for X-camera complete**



**Position:** 2  
**Type of part:**  
Unit

**Machine type:**

TP9-1 , TP9-2 , TP9-3 , TP9-4 , TP11 , TP12 , TP18

Part no.	Product name
L-012-0049B	Lens for X-camera complete

**Lamp 12V, 3W**



**Position:** 3  
**Type of part:**  
Electrical component

**Description**

Four used on X Wagon camera 1.  
Two used on X Wagon camera 2.

**Machine type:**

MY12 , MY15 , MY19 , MY9 , TP11 , TP12 , TP18 , TP9-1 , TP9-2 , TP9-3 , TP9-4

**Requirements:**

SONY camera.

Part no.	Product name
E-040-0102	Lamp 12V, 3W

**Cable wagon MY-series**



Part no.	Product name
L-043-0044	Cable wagon complete with rollers MY9
L-043-0043	Cable wagon complete with rollers MY12
L-043-0025	Cable wagon complete with rollers MY15
L-043-0003	Cable wagon complete with rollers MY19

**Cable wagon TP-series**

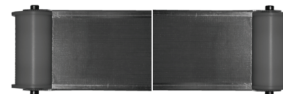

Part no.	Product name
L-013-0015	Cable wagon complete TP9-1/2
L-013-0115	Cable wagon complete TP9-3
L-013-0127	Cable wagon complete TP9-4
L-013-0120	Cable wagon complete TP11

**Cable wagon TP-series 2**



**Description**

Only available for use with aramid rope. Machines that uses Tygaflor tape need to be upgraded before using this cable wagon.

Part no.	Product name
L-023-0033	Cable wagon complete TP12
L-023-0030	Cable wagon complete TP18

### Upgrade kit cable wagon



**Description**

Upgrade kit for modify the cable wagon from Tygaflor belt to kevlar rope.

Part no.	Product name
L-023-0039	Upgrade kit cable wagon TP12
L-023-0038	Upgrade kit cable wagon TP18

**Ordering info:**

Sold per meter

Part no.	Product name
K-013-0032	X-belt

### X-belt



**Type of part:**  
Belt

**Description**

50mm belt for X Wagon.

**Machine type:**

MY12 , MY15 , MY19 , MY9 , TP12 , TP18 , TP9-1 , TP9-2 , TP9-3

**Requirements:**

4.575m for TP9-1/2. 5.00m for TP9-3. 6.50m for TP12. 8.565m for TP18. 4.98m for MY9. 6.06m for MY12. 7.50m for MY15. 8.94m for MY19.

**Ordering info:**

Sold per meter

Part no.	Product name
K-013-0023	X-belt

### Belt T2.5/380 B=20



**Type of part:**  
Belt

**Description**

X gear belt between X-belt motor and bearing housing.

**Machine type:**

TP9-1 , TP9-2

Part no.	Product name
K-013-0003	Belt T2.5/380 B=20

### TST cable



**Type of part:**  
Cable

**Machine type:**

TP9-1 , TP9-2 , TP9-3 , TP9-4

Part no.	Product name
L-019-0068	TST cable

### X-belt

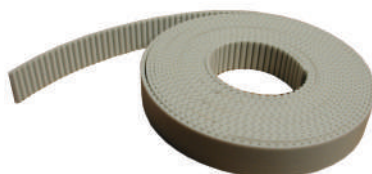

**Type of part:**  
Belt

**Description**

25mm belt for X Wagon.

**Machine type:**

TP9-4 , TP11

**Requirements:**

5.00m for TP9-4, 5.63m for TP11

### WSR-XVS cable kit

**Type of part:**  
Cable

**Description**  
Includes WSR2 cable and XVS vacuum cable

**Machine type:**  
MY9 , MY12 , MY15 , MY19

Part no.	Product name
L-049-0428	WSR-XVS cable kit

### WSR cable



**Type of part:**  
Cable

**Machine type:**  
TP9-1 , TP9-2

Part no.	Product name
L-019-0067B	WSR cable

### WSR2 cable

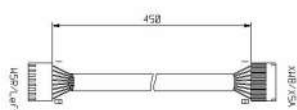

**Type of part:**  
Cable

**Description**  
Cable from WSR2 board to XWB(x) board.

**Machine type:**  
MY12 , MY15 , MY19 , MY9 , TP11 , TP9-3 , TP9-4

Part no.	Product name
L-019-0506	WSR2 cable

### XBMC belt motor cable

**Type of part:**  
Cable

**Machine type:**  
TP9-4 , TP11

Part no.	Product name
L-019-0544	XBMC belt motor cable

### XBOF booster flat cable

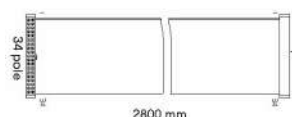

**Type of part:**  
Cable

**Machine type:**  
TP9-2

Part no.	Product name
L-019-0410	XBOF booster flat cable

### XBOF Booster flat cable



**Type of part:**  
Cable

**Description**  
Cable from Computer Box to Booster.

**Machine type:**  
TP9-1

Part no.	Product name
L-019-0077	XBOF Booster flat cable

**XBOP Booster power cable**



Type of part:  
Cable

**Description**

Cable from Computer Box to Booster.

**Machine type:**

TP9-1

Part no.	Product name
L-019-0072	XBOP Booster power cable

**XBOP Booster power cable**



Type of part:  
Cable

**Description**

Cable from Computer Box to Booster.

**Machine type:**

TP9-2

Part no.	Product name
L-019-0409	XBOP Booster power cable

**XCCP centering camera cable**

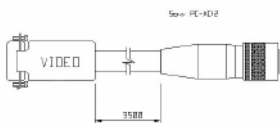

Type of part:  
Cable

**Machine type:**

TP9-2

**Requirements:**

PC-vision

Part no.	Product name
L-019-0442	XCCP centering camera cable

**XCP crude power cable**



Type of part:  
Cable

**Machine type:**

TP9-1

Part no.	Product name
L-019-0071	XCP crude power cable

**XCP crude power cable**

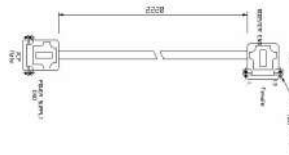

Type of part:  
Cable

**Machine type:**

TP9-2 , TP9-3

Part no.	Product name
L-019-0408	XCP crude power cable

**XETC ELMO timer cable**



Type of part:  
Cable

**Machine type:**

TP9-4 , TP11



Part no.	Product name
L-019-0658	XETC ELMO timer cable

### XP2 TST2 sync. cable



Type of part:  
Cable

#### Description

Cable between both TST2 boards.

#### Machine type:

TP12

Part no.	Product name
L-029-0200B	XP2 TST2 sync. cable

### XP2 TST2 sync. cable



Type of part:  
Cable

#### Description

Cable between both TST2 boards.

#### Machine type:

TP18

Part no.	Product name
L-029-0201B	XP2 TST2 sync. cable

### XTF cable

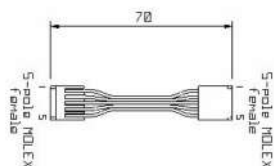

Type of part:  
Cable

#### Machine type:

TP9-3 , TP9-4 , TP11 , TP12 , TP18

Part no.	Product name
L-019-0456	XTF cable

### XVC camera cable



Type of part:  
Cable

Part is replacing:  
L-019-0307B

#### Description

Cable from Positioning Video Camera to XWB(x) board.

#### Machine type:

MY12 , MY15 , MY19 , MY9 , TP11 , TP12 , TP18 , TP9-1 , TP9-2 , TP9-3 , TP9-4

#### Requirements:

SONY camera

Part no.	Product name
L-029-0153	XVC camera cable

### XXFS fan sensor cable



Type of part:  
Cable

#### Machine type:

TP12 , TP18

Part no.	Product name
L-029-0041	XXFS fan sensor cable

**XXW1-2 50 pole cable**



Type of part:  
Cable

**Description**

Blue Hi-Flex 50-pole ribbon cable.

**Machine type:**

MY19

Part no.	Product name
L-049-0033	XXW1-2 50 pole cable

**XXW1-2 50 pole cable**

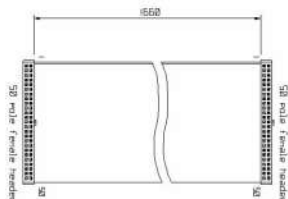

Type of part:  
Cable

**Description**

Blue Hi-Flex 50 pole ribbon cable.

**Machine type:**

TP11

Part no.	Product name
L-019-0525	XXW1-2 50 pole cable

**XXW1-2 50 pole cable**

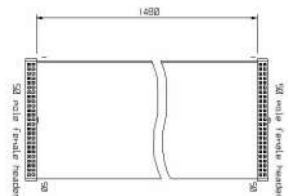

Type of part:  
Cable

**Machine type:**

TP9-3 , TP9-4

Part no.	Product name
L-019-0455	XXW1-2 50 pole cable

**XXW1-2 X Wagon cable**



Type of part:  
Cable

**Description**

Blue Hi-Flex 50 pole ribbon cable.

**Machine type:**

MY12

Part no.	Product name
L-049-0166	XXW1-2 X Wagon cable

**XXW1-2 X Wagon cable**

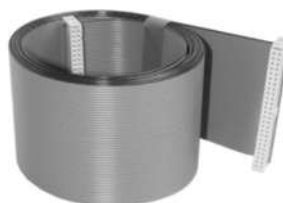

Type of part:  
Cable

**Description**

Blue Hi-Flex 50 pole ribbon cable.

**Machine type:**

MY15

Part no.	Product name
L-049-0035	XXW1-2 X Wagon cable

### XXW1-2 X Wagon cable



**Type of part:**  
Cable

**Description**

Blue Hi-Flex 50 pole ribbon cable.

**Machine type:**

MY9

Part no.	Product name
L-049-0168	XXW1-2 X Wagon cable

### XXW1-2, XXW3 50 pole cable

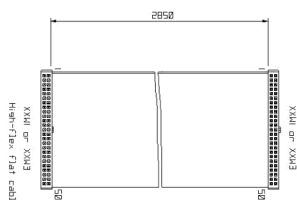

**Type of part:**  
Cable

**Description**

Blue Hi-Flex 50 pole ribbon cable.

**Machine type:**

TP12 , TP18

Part no.	Product name
L-029-0011	XXW1-2, XXW3 50 pole cable

### XXW1 cable 50 pole



**Type of part:**  
Cable

**Description**

Blue Hi-Flex 50 pole ribbon cable

**Machine type:**

TP9-1 , TP9-2

**Requirements:**

TP9-1 needs to be upgraded with L-019-0078B before using this cable

Part no.	Product name
L-019-0407	XXW1 cable 50 pole

### XXW1 cable 50 pole sectioned



**Type of part:**  
Cable

**Part is replacing:**

L-019-0078

**Description**

This upgrade kit makes it easier to replace the wearable XXW1 cable section. instead of going from Computer Box to XWB(x) board this goes from back panel of the machine to XWB(x).

**Machine type:**

TP9-1

Part no.	Product name
L-019-0078B	XXW1 cable 50 pole sectioned

### XXW2-2, XXW4 40 pole cable

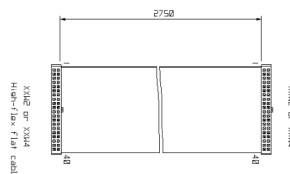

**Type of part:**  
Cable

**Description**

Blue Hi-Flex 40 pole ribbon cable.

**Machine type:**

TP12 , TP18

Part no.	Product name
L-029-0012	XXW2-2, XXW4 40 pole cable

**XXW2 cable 40 pole**

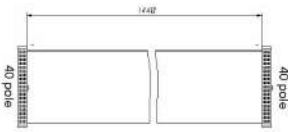

**Type of part:**  
Cable

**Description**

Blue Hi-Flex 40 pole ribbon cable

**Machine type:**

TP9-1 , TP9-2

**Requirements:**

TP9-1 needs to be upgraded with L-019-0079B before using this cable

Part no.	Product name
L-019-0406	XXW2 cable 40 pole

**Machine type:**

MY19

Part no.	Product name
L-049-0034	XXW2A+B - 2 X wagon cable

**XXW2A+B 60 pole cable**

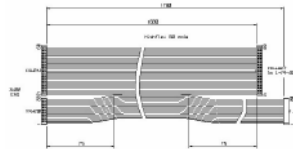

**Type of part:**  
Cable

**Description**

Blue Hi-Flex 60 pole ribbon cable.

**Machine type:**

TP11

Part no.	Product name
L-019-0526	XXW2A+B 60 pole cable

**XXW2 cable 40 pole sectioned**



**Type of part:**  
Cable

**Part is replacing:**  
L-019-0079

**Description**

This upgrade kit makes it easier to replace the wearable XXW1 cable section. Instead of going from Computer Box to XWB(x) board this goes from back panel of the machine to XWB(x).

**Machine type:**

TP9-1

Part no.	Product name
L-019-0079B	XXW2 cable 40 pole sectioned

**XXW2A+B 60 pole cable**

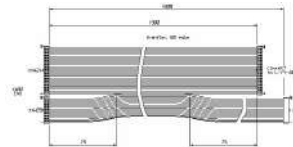

**Type of part:**  
Cable

**Description**

Blue Hi-Flex 60 pole ribbon cable.

**Machine type:**

TP9-3 , TP9-4

Part no.	Product name
L-019-0450	XXW2A+B 60 pole cable

**XXW2A+B - 2 X wagon cable**



**Type of part:**  
Cable

**Description**

Blue Hi-Flex 60 pole ribbon cable.

**XXW2A+B X Wagon cable**



**Type of part:**  
Cable

**Description**

Blue Hi-Flex 60 pole ribbon cable.

**Machine type:**  
MY9

Part no.	Product name
L-049-0169	XXW2A+B X Wagon cable

**XXW2A+B X Wagon cable**



**Type of part:**  
Cable

**Description**  
Blue Hi-Flex 60 pole ribbon cable.

**Machine type:**  
MY15

Part no.	Product name
L-049-0036	XXW2A+B X Wagon cable

**XXW2A+B X Wagon cable**



**Type of part:**  
Cable

**Description**  
Blue Hi-Flex 60 pole ribbon cable.

**Machine type:**  
MY12

Part no.	Product name
L-049-0167	XXW2A+B X Wagon cable

**Middle belt pulley**



**Type of part:**  
Cog wheel

**Description**  
Belt pulley for x-motor side bearing housing.

**Machine type:**  
TP9-1 , TP9-2

Part no.	Product name
D-013-0019-4	Middle belt pulley

**74HC244**



**Type of part:**  
Electrical component

**Description**  
IC6 on XWB board. IC7 & IC9 on MI edition 5C.

**Machine type:**  
MY12 , MY15 , MY19 , MY9 , TP11 , TP12 , TP18 , TP9-1 , TP9-2 , TP9-3 , TP9-4

Part no.	Product name
SH74HC244	74HC244

**8x400 mA 90V Darlington driver**



**Type of part:**  
Electrical component

**Description**  
Used on IC5, IC12, IC35 & IC36 on MI-board. IC4 on XWB board

**Machine type:**  
TP9-1 , TP9-2 , TP9-3 , TP9-4 , TP11 , TP12 , TP18

Part no.	Product name
SHL603	8x400 mA 90V Darlington driver

### ELMO Motherboard 1

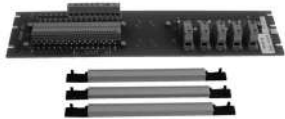

**Type of part:**  
Electrical component

**Description**  
MBA-EBA/6U.

**Machine type:**  
TP9-3 , TP9-4 , TP11 , TP12 , TP18

Part no.	Product name
K-029-0017	ELMO Motherboard 1

Part no.	Product name
K-029-0016	Elmo power supply board

### ELMO Servo amplifier



**Type of part:**  
Electrical component

**Machine type:**  
MY12 , MY15 , MY19 , MY9 , TP12 , TP18

Part no.	Product name
K-029-0015	ELMO Servo amplifier

### ELMO Motherboard 2

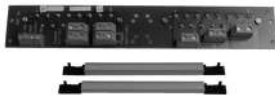

**Type of part:**  
Electrical component

**Description**  
MBP-PSS/6U.

**Machine type:**  
TP12 , TP18

Part no.	Product name
K-029-0018	ELMO Motherboard 2

### Fan axial 80x80x38 230V



**Type of part:**  
Electrical component

**Machine type:**  
TP11 , TP9-4

Part no.	Product name
E-992-0015	Fan axial 80x80x38 230V

### Elmo power supply board

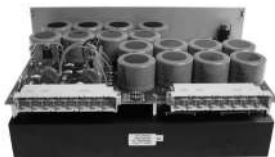

**Type of part:**  
Electrical component

**Description**  
PSS-30/400R.

**Machine type:**  
MY12 , MY15 , MY19 , MY9 , TP12 , TP18

### Fan ELMO



**Type of part:**  
Electrical component

**Machine type:**  
TP9-4 , TP11

Part no.	Product name
L-019-0785	Fan ELMO

### Fuse kit Booster



**Type of part:**  
Electrical component

#### Description

- 10 pcs Fuse quick 100mA 20mm
- 10 pcs Fuse quick 1A 20mm
- 10 pcs Fuse quick 4A 20mm
- 10 pcs Fuse quick 8A 20mm

#### Machine type:

TP9-2 , TP9-4 , TP11

Part no.	Product name
L-019-1002	Fuse kit Booster

### Lamp 12V, 20W



**Type of part:**  
Electrical component

#### Machine type:

TP9-1

#### Requirements:

Hitachi camera.

Part no.	Product name
E-040-0100	Lamp 12V, 20W

### Relay emergency stop 24V

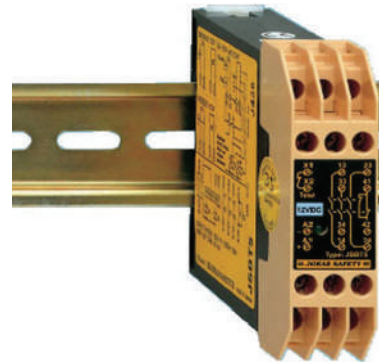

**Type of part:**  
Electrical component

#### Description

JSBT5T

#### Machine type:

MY12 , MY15 , MY19 , MY9

Part no.	Product name
E-013-0015	Relay emergency stop 24V

### XXME X-motor transducer



**Type of part:**  
Electrical component

#### Description

For X-belt motor.

#### Machine type:

TP12 , TP18

Part no.	Product name
L-029-0232	XXME X-motor transducer

### XXME X-motor transducer



**Type of part:**  
Electrical component

**Part is replacing:**  
L-049-0120

#### Description

For X-belt motor. Resolution 6 um.

Hengstler 0523 785

**Machine type:**  
MY12 , MY15 , MY19 , MY9

Part no.	Product name
L-049-0120B	XXME X-motor transducer

### XXME X-motor transducer



**Type of part:**  
Electrical component

**Part is replacing:**  
L-019-0619

**Description**  
For X-belt motor. Resolution 2 um.  
Hengstler RI58-O/6875AS.

**Machine type:**  
MY12 , MY15 , MY19 , MY9 , TP11 , TP9-4

Part no.	Product name
L-019-0619B	XXME X-motor transducer

**Description**  
Left side transducer for x-belt motor. AMI 0110/74 2500PPR

**Machine type:**  
TP9-1 , TP9-2

Part no.	Product name
L-019-0297B	XXWT X-motor transducer

### XXWT X-motor transducer



**Type of part:**  
Electrical component

**Part is replacing:**  
L-019-0759

**Description**  
For X-belt motor. Hengstler RI58-O 2500P.

**Machine type:**  
TP9-2

Part no.	Product name
L-019-0759B	XXWT X-motor transducer

### XXME X-motor transducer



**Type of part:**  
Electrical component

**Description**  
AMI 0100/166 4583 5V

**Machine type:**  
TP9-3

Part no.	Product name
L-019-0464	XXME X-motor transducer

### XXWT X Wagon transducer



**Type of part:**  
Electrical component

**Part is replacing:**  
L-019-0075B

**Description**  
Right side transducer. Hengstler RI58-O 5000P is replacing AMI 0110/74 5000PPR.

D-013-0172-3 needed when changing from transducer type Elcis to a newer AMI or Hengstler type. Four pcs K-022-0022 + screws also needed.

**Machine type:**  
TP9-1 , TP9-2

Part no.	Product name
L-019-0075E	XXWT X Wagon transducer

### XXWT X-motor transducer



**Type of part:**  
Electrical component



### XXWT X Wagon transducer



**Type of part:**  
Electrical component

**Description**

For X Wagon motor. Hengstler RI58-0 7854AS.

**Machine type:**

TP11 , TP9-4

Part no.	Product name
L-019-0618	XXWT X Wagon transducer

### XXWT X Wagon transducer



**Type of part:**  
Electrical component

**Description**

AMI 0100/144 2618 5V

**Machine type:**

TP9-3

Part no.	Product name
L-019-0460	XXWT X Wagon transducer

### Cable wagon upgrade



**Type of part:**  
Kit

**Description**

Upgrade kit for upgrading from Kevlar rope to Tygaflor tape.

**Machine type:**

TP12 , TP18

Part no.	Product name
L-023-0110	Cable wagon upgrade

### Drive axle with bearings



**Type of part:**  
Kit

**Machine type:**

TP9-3 , TP9-4 , TP11

Part no.	Product name
L-013-0139	Drive axle with bearings

### Drive shaft repair kit

**Type of part:**

Kit

**Part is replacing:**

L-043-0020

**Description**

Complete drive shaft with bearings.

**Machine type:**

MY12 , MY15 , MY19 , MY9

Part no.	Product name
L-043-0066	Drive shaft repair kit

### Drive shaft with bearings



**Type of part:**  
Kit

**Machine type:**

TP12 , TP18

Part no.	Product name
L-023-0003	Drive shaft with bearings

### Power transistor kit



**Type of part:**  
Kit

#### Description

- Includes these items.  
 1 pcs 2SJ55 MOSFET P TO-3  
 1 pcs 2SK175 MOSFET N 180V 8A TO-3  
 1 pcs 2SK213 FET N 140V 500mA TO220  
 1 pcs BYW64 Bridge  
 1 pcs MJ14000 or MJ14002 TO3  
 1 pcs MJ14001 or MJ14003 TO3  
 1 pcs TIP142 TO218 NPN DARL  
 1 pcs TIP147 TO218 PNP DARL  
 1 pcs TIP31B TO220 NPN  
 1 pcs TIP32C TO220 PNP  
 1 pcs STAB. +24V 1.0A TO-220  
 1 pcs STAB. +12V 3.0A TO-220  
 1 pcs STAB. -24V 1.0A TO-220  
 1 pcs STAB. - 5V 1.5A +-2.5% TO220  
 1 pcs STAB. +12V 1.5A TO-220

#### Machine type:

TP9-1 , TP9-2 , TP9-3 , TP9-4 , TP11 , TP12 , TP18

Part no.	Product name
L-019-0010	Power transistor kit

### X-wagon encoder kit

**Type of part:**  
Kit

**Part is replacing:**  
L-049-0014B

**Description**  
2 um encoder

**Machine type:**  
MY9 , MY12 , MY15 , MY19

Part no.	Product name
L-043-0104	X-wagon encoder kit

### Air spring, hood



**Type of part:**  
Mechanical component

#### Description

Aditech 9 070 091.

#### Machine type:

TP11 , TP9-4

Part no.	Product name
K-011-0028	Air spring, hood

### Antistatic roller, cable wagon



**Type of part:**  
Mechanical component

#### Machine type:

TP9-1 , TP9-2 , TP9-3 , TP9-4 , TP11

Part no.	Product name
L-013-0019	Antistatic roller, cable wagon

### Assembly sheave



**Type of part:**  
Mechanical component

#### Machine type:

TP9-1 , TP9-2 , TP9-3

Part no.	Product name
K-022-0022	Assembly sheave

**Component reject bin**



**Type of part:**  
Mechanical component

**Machine type:**  
TP9-1 , TP9-2 , TP9-3 , TP9-4 , TP11

Part no.	Product name
K-011-0010	Component reject bin

**End stop**



**Type of part:**  
Mechanical component

**Machine type:**  
TP12 , TP18

Part no.	Product name
D-021-0248-4	End stop

**Flexible joint 14/19**



**Type of part:**  
Mechanical component

**Description**  
Flexible joint between x-belt motor and bearing housing shaft.

**Machine type:**  
TP9-3

Part no.	Product name
K-013-0025	Flexible joint 14/19

**Flexible joint 14/19**

**Type of part:**  
Mechanical component

**Machine type:**  
TP9-3 , TP9-4 , TP11

Part no.	Product name
K-013-0025	Flexible joint 14/19

**Flexible joint 19x24**



**Type of part:**  
Mechanical component

**Description**  
Coupling between x-belt motor and bearing housing shaft.

**Machine type:**

MY12, MY15, MY19, MY9, TP11, TP12, TP18, TP9-4

Part no.	Product name
K-023-0001	Flexible joint 19x24

**Flexible joint 6/10**



**Type of part:**  
Mechanical component

**Description**

Coupling between X-belt motor and transducer.

**Machine type:**

MY15, MY19, TP11, TP12, TP18, TP9-3, TP9-4

Part no.	Product name
K-023-0005	Flexible joint 6/10

**Flexible joint DKN 15/26**



Component  
g:

**Description**

Flexible joint for transducer side.

**Machine type:**

TP9-1, TP9-2

Part no.	Product name
K-013-0036	Flexible joint DKN 15/26

**Flexible joint DKN20/30 spec**

**Type of part:**

Mechanical component

**Part is replacing:**

K-043-004B

**Description**

Coupling between X-belt motor and transducer.

**Machine type:**

MY9, MY12, MY15, MY19

Part no.	Product name
K-043-0004B	Flexible joint DKN20/30 spec

**Flexible joint X-motor**



**Type of part:**  
Mechanical component

**Description**

Flexible joint for X-motor side.

**Machine type:**

TP9-1, TP9-2

Part no.	Product name
K-013-0021	Flexible joint X-motor

**Ground pin for X-belt**

**Type of part:**

Mechanical component

**Machine type:**  
TP9-1 , TP9-2

Part no.	Product name
D-011-0166-4	Ground pin for X-belt

**Guide wheel, fixed, X wagon**



**Type of part:**  
Mechanical component

**Machine type:**  
MY9 , MY12 , MY15 , MY19

Part no.	Product name
K-042-0001	Guide wheel, fixed, X wagon

**Guide wheel, X Wagon**



**Type of part:**  
Mechanical component

**Machine type:**  
TP9-3 , TP9-4 , TP11 , TP12 , TP18 , MY9 , MY12 , MY15 , MY19

Part no.	Product name
K-022-0003	Guide wheel, X Wagon

**Pump unit , green**



**Type of part:**  
Mechanical component

**Machine type:**  
MY12 , MY15 , MY19 , MY9 , TP12 , TP18

Part no.	Product name
K-023-0013	Pump unit , green

**Transducer bracket**

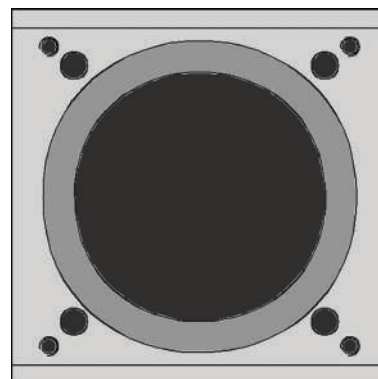

**Type of part:**  
Mechanical component

**Description**  
Needed when changing from transducer type Elcis to a newer AMI or Hengstler type.  
Four pcs K-022-0022 + screws also needed.

**Machine type:**  
TP9-1 , TP9-2

Part no.	Product name
D-013-0172-3	Transducer bracket

**X-belt bearing housing, left**



**Type of part:**  
Mechanical component

**Machine type:**  
TP9-1 , TP9-2

**Requirements:**  
Single belt drive on X axis.

Part no.	Product name
L-013-0014C	X-belt bearing housing, left

### X-belt bearing housing, right



**Type of part:**  
Mechanical component

**Machine type:**  
TP9-1 , TP9-2

**Requirements:**  
Single belt drive on X axis.

Part no.	Product name
L-013-0013C	X-belt bearing housing, right

### X-rail profile, lower

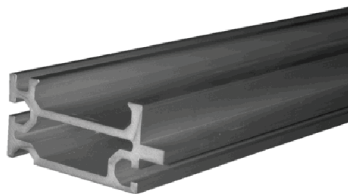

**Type of part:**  
Mechanical component

**Description**  
Long aluminium rail profile that guides nylon wheels on the X Wagon. This is the lower rail.

**Machine type:**  
TP9-1 , TP9-2

Part no.	Product name
D-011-0083-4	X-rail profile, lower

### X-rail profile, upper

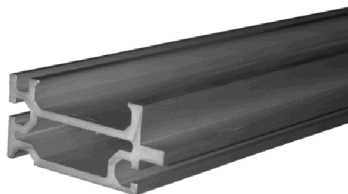

**Type of part:**  
Mechanical component

**Description**  
Long aluminium rail profile that guides nylon wheels on the X Wagon. This is the upper rail.

**Machine type:**  
TP9-1 , TP9-2

Part no.	Product name
D-011-0087-3	X-rail profile, upper

### Carbon Brush for F12 M4



**Type of part:**  
Miscellaneous

**Description**  
Carbon brush for X Wagon motor.

**Machine type:**  
MY12 , MY15 , MY19 , MY9 , TP12 , TP18

Part no.	Product name
K-029-0035	Carbon Brush for F12 M4

### Fan, X Wagon motor



**Type of part:**  
Miscellaneous

**Description**  
Papst RL 90-18/24. For X Wagon motor on TP12 and TP18.

**Machine type:**  
TP12 , TP18

Part no.	Product name
K-022-0002	Fan, X Wagon motor

### Flexible joint 6x6



**Type of part:**  
Miscellaneous

**Description**

Coupling between the X Wagon motor and transducer.

**Machine type:**

TP11 , TP12 , TP18 , TP9-3 , TP9-4

**Part no.****Product name**

Part no.	Product name
K-022-0023	Flexible joint 6x6

**Flexible joint DKN 4/21****Type of part:**

Miscellaneous

**Description**

Coupling between X Wagon motor and transducer.

**Machine type:**

MY9 , MY12 , MY15 , MY19

**Part no.****Product name**

Part no.	Product name
K-042-0018	Flexible joint DKN 4/21

**Grease paste****Type of part:**

Miscellaneous

**Description**

For cog belts.

Type: OKS 270

**Machine type:**

MY12 , MY15 , MY19 , MY9 , TP11 , TP12 , TP18 , TP9-1 , TP9-2 , TP9-3 , TP9-4

**Part no.****Product name**

Part no.	Product name
K-013-0014	Grease paste

**Grease paste for X-rail****Type of part:**

Miscellaneous

**Description**

Grease paste for lubricating X-rail and nylon wheels.

**Machine type:**

TP9-1 , TP9-2

**Part no.****Product name**

Part no.	Product name
K-013-0028	Grease paste for X-rail

**Grease Tube Retinax EP 2****Type of part:**

Miscellaneous

**Description**

Grease for X-rail.

**Machine type:**

MY12 , MY15 , MY19 , MY9 , TP11 , TP12 , TP18 , TP9-3 , TP9-4

**Requirements:**

For Grease gun L-015-0395.

**Part no.****Product name**

Part no.	Product name
K-015-0091	Grease Tube Retinax EP 2



### Kevlar rope 3mm

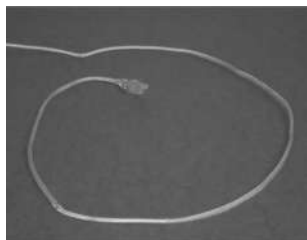

**Type of part:**  
Miscellaneous

**Machine type:**  
TP12 , TP18

Part no.	Product name
K-023-0026	Kevlar rope 3mm

### Nylon wheel

**Type of part:**  
Miscellaneous

**Part is replacing:**  
K-015-0008

**Description**  
Nylon wheel for X Wagon.

**Machine type:**  
TP9-1 , TP9-2

Part no.	Product name
L-012-0852	Nylon wheel

### Nylon wheel for X and Y



**Type of part:**  
Miscellaneous

**Description**  
Nylon wheel for X Wagon.

**Machine type:**  
TP9-1 , TP9-2

Part no.	Product name
K-015-0008	Nylon wheel for X and Y

### Shock absorber Weforma

**Type of part:**  
Miscellaneous

**Part is replacing:**  
K-043-0007

**Machine type:**  
TP9-4 , TP11 , MY9 , MY12 , MY15 , MY19

Part no.	Product name
K-043-0010	Shock absorber Weforma

### Shock arbsorber Weforma

**Type of part:**  
Miscellaneous

**Part is replacing:**  
K-013-0007

**Machine type:**  
TP9-1 , TP9-2

Part no.	Product name
K-013-0035	Shock arbsorber Weforma

### Tygaflor tape 24mm



**Type of part:**  
Miscellaneous

**Part is replacing:**  
K-023-0019

**Machine type:**  
MY12 , MY15 , MY19 , MY9 , TP12 , TP18

**Requirements:**  
5.0 m per cable wagon on TP18. 4.0 m per cable wagon on TP12.  
5.0 m per cable wagon on MY19. 4.0 m per cable wagon on MY15.  
3.5 m per cable wagon on MY12. 3.0 m per cable wagon on MY9.



Part no.	Product name
----------	--------------

U-023-0001	Tygaflor tape 24mm
------------	--------------------

### X-rail cleaner

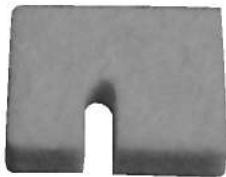

**Type of part:**  
Miscellaneous

#### Description

For keeping x-rail profile free from dirt and components which can otherwise make the x-rail wear out prematurely.

#### Machine type:

TP9-1 , TP9-2

Part no.	Product name
----------	--------------

D-012-0270-4	X-rail cleaner
--------------	----------------

### X Wagon motor connector

#### Type of part:

Miscellaneous

#### Description

To be used to replace the connector on the X Wagon motor connector if having problem. This is an improved version of the connector used on newer generation machines.

#### Machine type:

MY12 , MY15 , MY19 , MY9

Part no.	Product name
----------	--------------

L-049-0091	X Wagon motor connector
------------	-------------------------

### X-belt motor

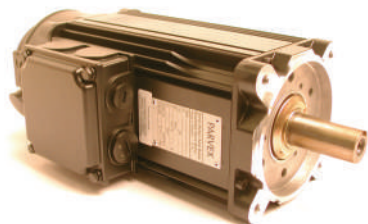

**Type of part:**  
Motor

#### Machine type:

TP11 , TP9-4

Part no.	Product name
----------	--------------

K-013-0031B	X-belt motor
-------------	--------------

### X-belt motor

#### Type of part:

Motor

#### Description

GEC Alstrom: Axem MD17HSR0001.

#### Machine type:

TP9-3

Part no.	Product name
----------	--------------

K-013-0026	X-belt motor
------------	--------------

### X-belt motor kit

#### Type of part:

Motor

#### Part is replacing:

K-023-0004B

#### Description

Motor complete with encoder

#### Machine type:

TP12 , TP18 , MY9 , MY12 , MY15 , MY19

#### Ordering info:

Please state machine serial number when ordering.

Part no.	Product name
----------	--------------

L-043-0067	X-belt motor kit
------------	------------------

**X-motor with cogwheel**



**Type of part:**  
Motor

**Machine type:**  
TP9-1 , TP9-2

Part no.	Product name
L-019-0195	X-motor with cogwheel

**X-wagon motor MY refurbished**

**Type of part:**  
Motor

**Description**  
Refurbished X-wagon motor - L-049-0118

**Machine type:**  
MY9 , MY12 , MY15 , MY19

**Ordering info:**  
Check for availability before order.

Part no.	Product name
L-049-0698	X-wagon motor MY refurbished

**X Wagon motor**



**Type of part:**  
Motor

**Machine type:**  
TP11 , TP9-3 , TP9-4

Part no.	Product name
L-019-0462	X Wagon motor

**X Wagon motor**



**Type of part:**  
Motor

**Machine type:**  
TP12 , TP18

Part no.	Product name
L-029-0024	X Wagon motor

**MOT3D with front panel**

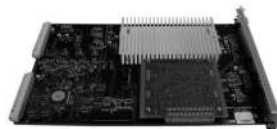

**Type of part:**  
PCB

**Description**  
MOT3 board for machines with DSP servo. Only for X movement.

**Machine type:**  
MY12 , MY15 , MY19 , MY9

Part no.	Product name
L-049-0248	MOT3D with front panel

**MPS motherboard power supply**

**Type of part:**  
PCB

**Description**

Motherboard Power Supply. A power supply for the Elmo unit.

**Machine type:**

TP9-4 , TP11

Part no.	Product name
----------	--------------

L-019-0588-1B	MPS motherboard power supply
---------------	------------------------------

Part no.	Product name
----------	--------------

L-029-0310-3B	PAIB2
---------------	-------

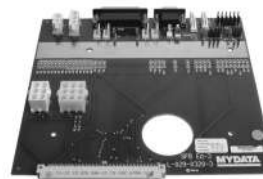
**SFB filter board elmobox**

**Type of part:**  
PCB

**Part is replacing:**

L-029-0320-2D

**Machine type:**

MY9 , MY12 , MY15 , MY19

Part no.	Product name
----------	--------------

L-029-0320-3	SFB filter board elmobox
--------------	--------------------------

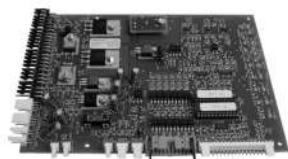
**PAIB Power amp. interface board**

**Type of part:**  
PCB

**Machine type:**

TP9-3 , TP9-4 , TP11 , TP12 , TP18

Part no.	Product name
----------	--------------

L-029-0091-2B	PAIB Power amp. interface board
---------------	---------------------------------

**TST ed. 1**

**Type of part:**  
PCB

**Machine type:**

TP9-1 , TP9-2

Part no.	Product name
----------	--------------

L-019-0065-1	TST ed. 1
--------------	-----------

**PAIB2**

**Type of part:**  
PCB

**Part is replacing:**  
L-029-0310-1B

**Machine type:**

MY9 , MY12 , MY15 , MY19

**TST2 spare part****Type of part:**

PCB

**Part is replacing:**

L-029-0037-3-M

**Machine type:**

TP9-3 , TP9-4 , TP11 , TP12 , TP18 , MY9 , MY12 , MY15 , MY19

Part no.	Product name
L-049-0635	TST2 spare part

Part no.	Product name
L-029-0179-4	XMEB edition 4

### WSR X-safety switch receiver



**Type of part:**  
PCB

**Part is replacing:**  
L-019-0063-4B

**Machine type:**  
TP9-1 , TP9-2

Part no.	Product name
L-019-0063-5C	WSR X-safety switch receiver

### XSS edition 3



**Type of part:**  
PCB

**Part is replacing:**  
L-029-0367-2

**Machine type:**  
TP9-4 , TP11 , TP12 , TP18 , MY9 , MY12 , MY15 , MY19

Part no.	Product name
L-029-0367-3	XSS edition 3

### WSR2 edition 5B

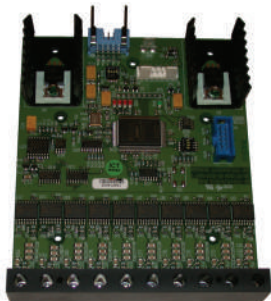

**Type of part:**  
PCB

**Part is replacing:**  
L-029-0036-3

**Machine type:**  
TP9-3 , TP9-4 , TP11 , TP12 , TP18 , MY9 , MY12 , MY15 , MY19

Part no.	Product name
L-029-0036-5B	WSR2 edition 5B

### XWMB2

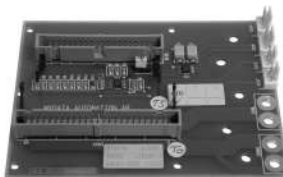

**Type of part:**  
PCB

**Machine type:**  
TP12 , TP18

Part no.	Product name
L-029-0180-2	XWMB2

### XMEB edition 4

**Type of part:**  
PCB

**Machine type:**  
TP9-3 , TP9-4 , TP11 , TP12 , TP18 , MY9 , MY12 , MY15 , MY19

### Belt tension roller



**Type of part:**  
Unit

**Machine type:**  
MY9 , MY12 , MY15 , MY19

Part no.	Product name
L-043-0012	Belt tension roller

### Belt tension roller



Type of part:  
Unit

**Machine type:**  
TP9-3 , TP9-4 , TP11 , TP12 , TP18

Part no.	Product name
L-023-0004B	Belt tension roller

### BNB edition 3

Type of part:  
Unit

**Part is replacing:**  
L-019-0624-2

**Machine type:**  
TP9-1 , TP9-2 , TP9-3 , TP9-4 , TP11 , TP12 , TP18 , MY9 , MY12 , MY15 , MY19

**Requirements:**  
For machines with BNB/NREG booster

Part no.	Product name
L-019-0624-3	BNB edition 3

### Booster 2 edition 3

Type of part:  
Unit

**Part is replacing:**  
L-019-0322-2

**Description**  
The BOOSTER2 is low voltage high power electronics assembled on a large cooling flange. It is a MOS FET current booster for the MOT-board.

**Machine type:**  
TP9-3 , TP9-4 , TP11 , TP12 , TP18 , MY9 , MY12 , MY15 , MY19

Part no.	Product name
L-019-0322-3	Booster 2 edition 3

### Booster BNB/NREG complete

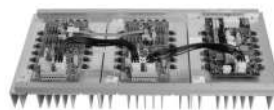

Type of part:  
Unit

**Machine type:**  
TP11 , TP9-2 , TP9-4

**Requirements:**  
Computer Box 2.

Part no.	Product name
L-019-0902	Booster BNB/NREG complete

### Booster spare part kit

Type of part:  
Unit

**Part is replacing:**  
L-019-0041-2C

**Machine type:**  
TP9-1 , TP9-2 , TP9-3 , TP9-4 , TP11 , TP12 , TP18

**Requirements:**  
Computer Box 1

Part no.	Product name
L-019-1113	Booster spare part kit

### Contact cover WSR2



Type of part:  
Unit

**Machine type:**  
TP9-3 , TP9-4 , TP11 , TP12 , TP18

Part no.	Product name
L-019-0667	Contact cover WSR2

### ELMO servo amplifier



Type of part:  
Unit

Machine type:  
TP11 , TP9-4

Part no.	Product name
U-029-0015	ELMO servo amplifier

### Emergency relay connector

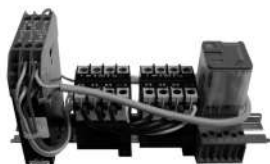

Type of part:  
Unit

Machine type:  
TP9-4 , TP11 , TP12 , TP18

Part no.	Product name
L-029-0275	Emergency relay connector

### Lamp housing X Wagon camera 2



Type of part:  
Unit

#### Description

Lamp housing without lenstube.

#### Machine type:

MY12 , MY15 , MY19 , MY9 , TP11 , TP12 , TP18 , TP9-2 , TP9-4

#### Requirements:

X Wagon camera 2.

Part no.	Product name
L-012-0121	Lamp housing X Wagon camera 2

### NREG edition 2B

#### Type of part:

Unit

#### Machine type:

TP9-4 , TP11 , MY9 , MY12 , MY15 , MY19

#### Requirements:

Machines equipped with BNB/NREG booster.

Part no.	Product name
L-019-0625-2B	NREG edition 2B

### OREG edition 2B

#### Type of part:

Unit

#### Machine type:

TP9-1 , TP9-2 , TP9-3 , TP9-4 , TP11 , TP12 , TP18

#### Requirements:

Booster - L-019-1113

Part no.	Product name
L-019-1013-2B	OREG edition 2B

### X-belt motor with transducer



Type of part:  
Unit

**Machine type:**

TP9-3

Part no.	Product name
L-013-0113	X-belt motor with transducer

**Retrofit XWB3 + motors****Type of part:**

Update kit

**Description**

These parts are included:

2 x Z-motor (L-019-0004B)

1 x Fi-motor (L-019-0007C)

1 x XWB3 board (L-029-00276-3B)

**Machine type:**

TP9-1

**Requirements:**

XWB ed. 3 or earlier version.

Part no.	Product name
L-012-0054	Retrofit XWB3 + motors

**Upgrade X axis to single belt****Type of part:**

Update kit

**Description**

Upgrade kit from double X-belt drive to single X-belt drive.

**Machine type:**

TP9-1

Part no.	Product name
L-013-0016B	Upgrade X axis to single belt

**Belt T2.5/285 B=6**



Type of part:  
Belt

Machine type:  
TP9-1

Requirements:  
Belt driven Y Wagon.

Part no.	Product name
K-015-0002	Belt T2.5/285 B=6

Part no.	Product name
K-015-0023	Belt T5/finite B=20 cord 0.48

**End-point switch Y-wagon with cable**

Type of part:  
Cable

Part is replacing:  
L-019-0237

Machine type:  
TP9-1 , TP9-2 , TP9-3 , TP9-4 , TP11 , TP12 , TP18

Part no.	Product name
L-019-0237B	End-point switch Y-wagon with cable

**Belt T2.5/950 B=18**



Type of part:  
Belt

Machine type:  
TP9-1

Requirements:  
Belt driven Y Wagon.

Part no.	Product name
K-015-0004	Belt T2.5/950 B=18

**XYF Y Wagon flat cable**

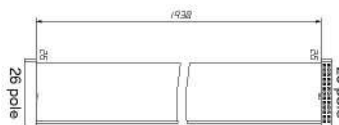

Type of part:  
Cable

Machine type:  
TP9-2 , TP9-3 , TP9-4 , TP11

Requirements:  
Computer Box 1.

Part no.	Product name
L-019-0411	XYF Y Wagon flat cable

**Belt T5/finite B=20 cord 0.48**

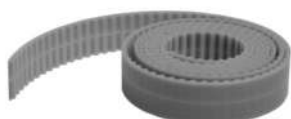

Type of part:  
Belt

Description  
1.5m per Y Wagon required.

Machine type:  
TP9-1

Requirements:  
Belt driven Y Wagon.



Type of part:  
Cable

Machine type:  
TP11



Part no.	Product name
L-019-0726	XYF2 Y Wagon flat cable 2

### XYF2 Y Wagon flat cable 2



**Type of part:**  
Cable

**Machine type:**  
TP9-4

Part no.	Product name
L-019-0725	XYF2 Y Wagon flat cable 2

### XYFA Y wagon cable adapter YWB



**Type of part:**  
Cable

**Machine type:**  
TP9-4, TP11

Part no.	Product name
L-019-0727	XYFA Y wagon cable adapter YWB

### XYFI Y Wagon flat cable int.



**Type of part:**  
Cable

**Machine type:**  
MY12, MY15, MY19, MY9, TP11, TP9-4

**Requirements:**  
Y Wagon Unit - YWU3, YWU4 or YWU5.

Part no.	Product name
L-019-0831	XYFI Y Wagon flat cable int.

### End-position switch rear



**Type of part:**  
Electrical component

**Machine type:**  
MY12, MY15, MY19, MY9, TP11, TP9-4

**Requirements:**  
Y Wagon Unit - YWU3, YWU4 or YWU5.

Part no.	Product name
L-019-0681	End-position switch rear

### End-position switch, front



**Type of part:**  
Electrical component

**Machine type:**  
MY12, MY15, MY19, MY9, TP11, TP9-4

**Requirements:**  
Y Wagon Unit - YWU3, YWU4 or YWU5.

Part no.	Product name
L-019-0682	End-position switch, front

### Safety switch for hood



**Type of part:**  
Electrical component

### Description

Titan TLS-1 24V 27004.

### Machine type:

MY12 , MY15 , MY19 , MY9 , TP11 , TP9-4

### Requirements:

288 or 468 Hood.

Part no.	Product name
K-015-0084	Safety switch for hood

### Safety switch for Y-wagon hood and TEX. Not for Pro-Line hoods.

### Type of part:

Electrical component

### Part is replacing:

K-024-0017

### Machine type:

MY12 , MY15 , MY19 , MY9 , TP11 , TP9-4 , Tray Exchanger

Part no.	Product name
L-024-0182	Safety switch for Y-wagon hood and TEX. Not for Pro-Line hoods.

### Safety switch YWU hood

### Type of part:

Electrical component

### Machine type:

MY12 , MY15 , MY19 , MY9

### Requirements:

ML3-6 Proline

Part no.	Product name
L-049-0252	Safety switch YWU hood

### Transducer with cables YWU



**Type of part:**  
Electrical component

### Description

Transducer for YWU3-5. RI58-F/5000AF.47RX-S

### Machine type:

MY12 , MY15 , MY19 , MY9 , TP11 , TP9-4

Part no.	Product name
L-015-0423	Transducer with cables YWU

### Y-transducer with cable

### Type of part:

Electrical component



### Description

Leine & Linde 4167 PPR.

### Machine type:

TP9-1

### Requirements:

Belt driven Y Wagon.

Part no.	Product name
L-019-0087B	Y-transducer with cable

### YM amplifier

### Type of part:

Kit

### Machine type:

MY9 , MY12 , MY15 , MY19

### Requirements:

Board handling system T3-T6

Part no.	Product name
L-045-0424	YM amplifier

## YM cable chain



**Type of part:**  
Kit

### Description

Cable chain with cables

### Machine type:

MY9 , MY12 , MY15 , MY19

### Requirements:

Board handling system T3-T6

Part no.	Product name
----------	--------------

L-045-0418	YM cable chain
------------	----------------

### Machine type:

MY9 , MY12 , MY15 , MY19

### Requirements:

Board handling system T3-T6

Part no.	Product name
----------	--------------

L-045-0427	YM grease
------------	-----------

## YM linear encoder

### Type of part:

Kit

### Machine type:

MY9 , MY12 , MY15 , MY19

### Requirements:

Board handling system T3-T6

Part no.	Product name
----------	--------------

L-045-0421	YM linear encoder
------------	-------------------

## YM crash protection kit



**Type of part:**  
Kit

### Description

4 bump protection brackets and 4 rubber damper included.

### Machine type:

MY9 , MY12 , MY15 , MY19

### Requirements:

Board handling system T3-T6

Part no.	Product name
----------	--------------

L-045-0417	YM crash protection kit
------------	-------------------------

## YM linear scale cleaning kit

### Type of part:

Kit

### Machine type:

MY12 , MY15 , MY19

Part no.	Product name
----------	--------------

L-045-0428	YM linear scale cleaning kit
------------	------------------------------

## YM linear scale replacement kit

### Type of part:

Kit

### Machine type:

MY9 , MY12 , MY15 , MY19

### Requirements:

Board handling system T3-T6

Part no.	Product name
----------	--------------

L-045-0422	YM linear scale replacement kit
------------	---------------------------------

## YM grease

### Type of part:

Kit

### Description

Grease with hand pump for lubricating YM-unit

### Bearing housing Y Wagon



**Type of part:**  
Mechanical component

**Description**

Four pieces in each Y Wagon Unit.  
Two pieces in each Tray wagon magazine.

**Machine type:**

TP9-1 , TP9-2 , TP9-3 , TP9-4 , TP11 , TP12 , TP18 , Magazine

**Requirements:**

YWU1, YWU2 or Tray wagon magazine

Part no.	Product name
K-015-0028-R	Bearing housing Y Wagon

**Machine type:**

MY12 , MY15 , MY19 , MY9 , TP11 , TP9-4

**Requirements:**

Y Wagon Unit - YWU3.

Part no.	Product name
U-015-0001	Lead screw with nut

### Lead screw with nut



**Type of part:**  
Mechanical component

**Machine type:**

MY12 , MY15 , MY19 , MY9 , TP11 , TP9-4

**Requirements:**

Y Wagon Unit - YWU4 or YWU5

Part no.	Product name
U-015-0002	Lead screw with nut

### Flexible joint 8/10



**Type of part:**  
Mechanical component

**Description**

For Y Wagon and Tray Elevator.

**Machine type:**

TP9-1 , TP9-2 , TP9-3 , TP9-4 , TP11 , TP12 , TP18

**Requirements:**

Y Wagon Unit - YWU1 or YWU2.

Part no.	Product name
K-015-0029	Flexible joint 8/10

### Plexiglass cover - 288 front

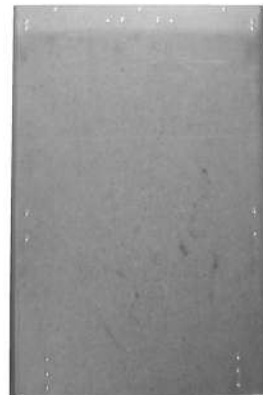

**Type of part:**  
Mechanical component

**Description**

Plexiglass front cover on 288 manual load Y Wagon.

**Machine type:**

MY12 , MY15 , MY19 , MY9 , TP11 , TP9-4

Part no.	Product name
D-015-0774-2	Plexiglass cover - 288 front

### Lead screw with nut



**Type of part:**  
Mechanical component

### Shaft coupling



**Type of part:**  
Mechanical component

**Description**

Coupling between motor and transducer.

**Machine type:**

MY12 , MY15 , MY19 , MY9 , TP11 , TP9-4

**Requirements:**

Y Wagon Unit - YWU3 or YWU4.

Part no.	Product name
K-015-0058	Shaft coupling

### Shaft coupling 12/14



**Type of part:**  
Mechanical component

**Description**

Coupling between motor and leadscrew.

**Machine type:**

MY12 , MY15 , MY19 , MY9 , TP11 , TP9-4

**Requirements:**

Y Wagon Unit - YWU3, YWU4 or YWU5.

Part no.	Product name
K-015-0055	Shaft coupling 12/14

### Steel axle with ball bushing



**Type of part:**  
Mechanical component

**Machine type:**

MY12 , MY15 , MY19 , MY9 , TP11 , TP9-4

**Requirements:**

Y Wagon Unit - YWU4 or YWU5

Part no.	Product name
U-015-0006-3	Steel axle with ball bushing

### Steel axle with ball bushing



**Type of part:**  
Mechanical component

**Machine type:**

MY12 , MY15 , MY19 , MY9 , TP11 , TP9-4

**Requirements:**

Y Wagon Unit - YWU3.

Part no.	Product name
U-015-0005	Steel axle with ball bushing

### Damper



**Type of part:**  
Miscellaneous

**Description**

Aditech 902174.

**Machine type:**

MY12 , MY15 , MY19 , MY9 , TP11 , TP9-4

**Requirements:**

Y Wagon table 288 or 468.

Part no.	Product name
K-015-0090	Damper

### Grease Tube NSK No. 1



**Type of part:**  
Miscellaneous

**Description**

To be used on the leadscrew on Y Wagon Unit - YWU3, YWU4 and YWU5.

**Machine type:**

MY12 , MY15 , MY19 , MY9 , TP11 , TP9-4

**Requirements:**

For Grease Gun L-015-0397

Part no.	Product name
U-015-0014	Grease Tube NSK No. 1

### Y Wagon motor filter box cable



**Type of part:**  
Miscellaneous

**Part is replacing:**  
L-019-0295

**Machine type:**  
TP9-1 , TP9-2 , TP9-3 , TP9-4 , TP11 , TP12 , TP18

**Requirements:**  
Y Wagon Unit - YWU1 or YWU2.

Part no.	Product name
L-019-0295B	Y Wagon motor filter box cable

### Mini motor HP servomotor (Y)



**Type of part:**  
Motor

**Machine type:**  
TP9-1

**Requirements:**  
Belt driven Y Wagon.

Part no.	Product name
L-019-0006	Mini motor HP servomotor (Y)

### Motor for lead screw Y Wagon



**Type of part:**  
Motor

**Part is replacing:**  
L-019-0012

**Machine type:**  
TP11 , TP12 , TP18 , TP9-1 , TP9-2 , TP9-3 , TP9-4

**Requirements:**  
Y Wagon Unit - YWU1, YWU2 or Tray Wagon Magazine.

Part no.	Product name
L-019-0012B	Motor for lead screw Y Wagon

### Motor with transducer



**Type of part:**  
Motor

**Part is replacing:**  
L-015-0326B

**Machine type:**  
MY12 , MY15 , MY19 , MY9 , TP11 , TP9-4

**Requirements:**  
Y Wagon Unit - YWU3, YWU4 or YWU5.

Part no.	Product name
L-015-0326C	Motor with transducer

### Y Wagon motor



**Type of part:**  
Motor

**Description**  
Motor for Y Wagon Unit - YWU3, YWU4 and YWU5.

**Machine type:**  
TP9-4 , TP11 , MY9 , MY12 , MY15 , MY19

Part no.	Product name
U-015-0008	Y Wagon motor

### YWB Y Wagon board



**Type of part:**  
PCB

**Machine type:**

TP9-1 , TP9-2 , TP9-3 , TP9-4 , TP11 , TP12 , TP18

Part no.	Product name
----------	--------------

L-019-0025-6	YWB Y Wagon board
--------------	-------------------

**YWB2 Y Wagon board 2****Type of part:**  
PCB**Machine type:**

MY12 , MY15 , MY19 , MY9 , TP11 , TP12 , TP18 , TP9-1 , TP9-2 , TP9-4

**Requirements:**

TPSys

Part no.	Product name
----------	--------------

L-019-0734-1	YWB2 Y Wagon board 2
--------------	----------------------

**Control Unit with cables****Type of part:**

Unit

**Description**

Guardmaster Sipha 24V AC/DC 32013 Relay

**Machine type:**

MY12 , MY15 , MY19 , MY9

**Requirements:**

ML3-6 Proline

Part no.	Product name
----------	--------------

L-049-0253	Control Unit with cables
------------	--------------------------

**Roller, cable tensioner****Type of part:**  
Unit**Machine type:**

MY12 , MY15 , MY19 , MY9 , TP11 , TP9-2 , TP9-4

**Requirements:**

270, 450, 500T, 500T2 or 420PT Conveyor.

Part no.	Product name
----------	--------------

L-015-0327	Roller, cable tensioner
------------	-------------------------

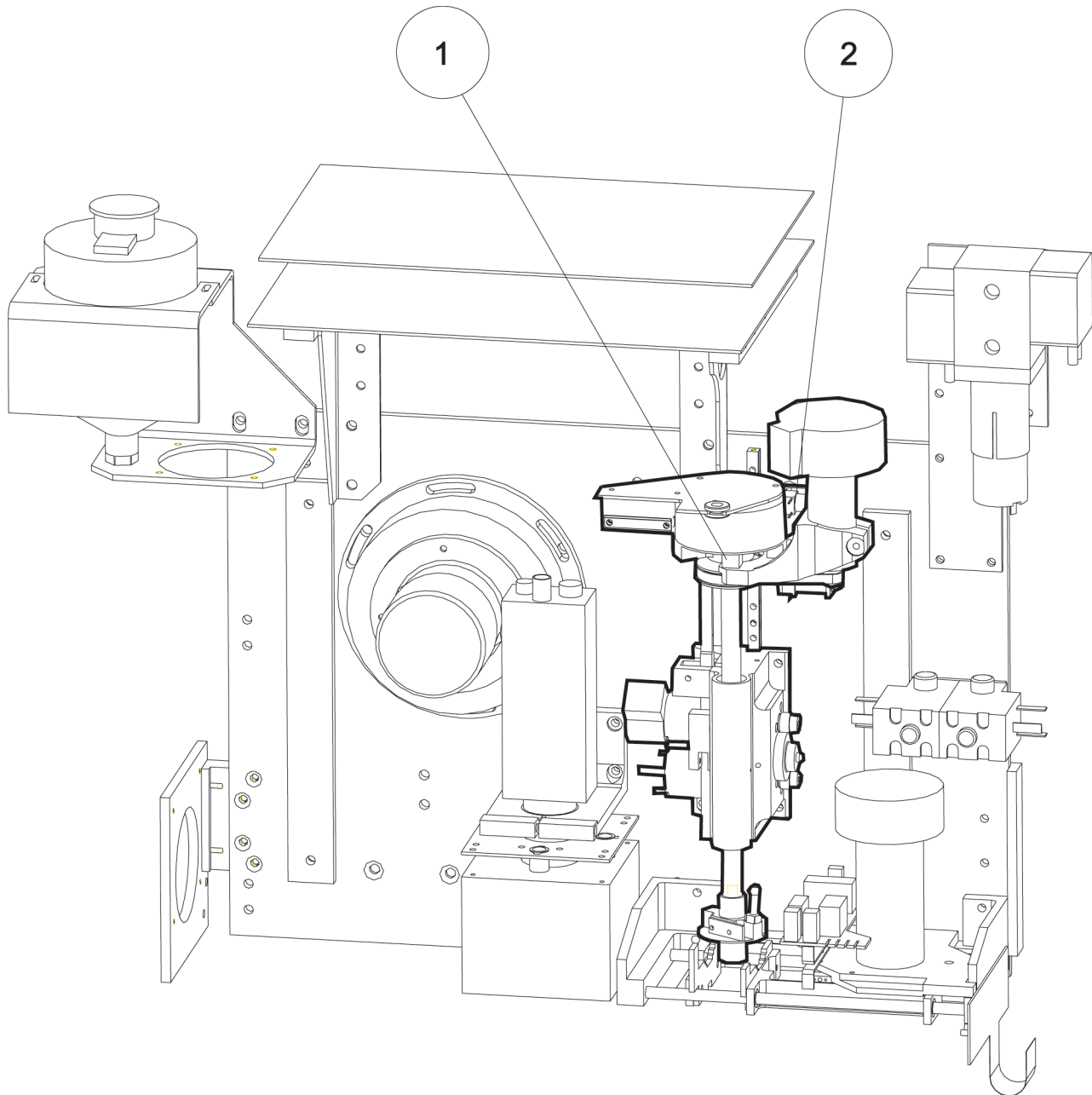



**Z-Fi unit with motors**



**Position:** 1  
**Type of part:**  
 Unit

**Machine type:**  
 MY12 , MY15 , MY19 , MY9 , TP11 , TP12 , TP18 , TP9-3 , TP9-4

Part no.	Product name
L-022-0050	Z-Fi unit with motors

**Z-lock bracket with magnets**



**Position:** 2  
**Type of part:**  
 Kit  
**Part is replacing:**  
 L-022-0065

**Description**  
 This Z-lock will fit both Z-Fi unit and Midas.

**Machine type:**  
 MY12 , MY15 , MY19 , MY9 , TP11 , TP12 , TP18 , TP9-3 , TP9-4

Part no.	Product name
L-022-0065B	Z-lock bracket with magnets

**Z-Fi unit without motors**



**Position:** 1  
**Type of part:**  
 Unit

**Description**  
 Same as L-022-0050 but this unit does not have any motors.

**Machine type:**  
 MY12 , MY15 , MY19 , MY9 , TP11 , TP12 , TP18 , TP9-3 , TP9-4

Part no.	Product name
L-022-0066	Z-Fi unit without motors

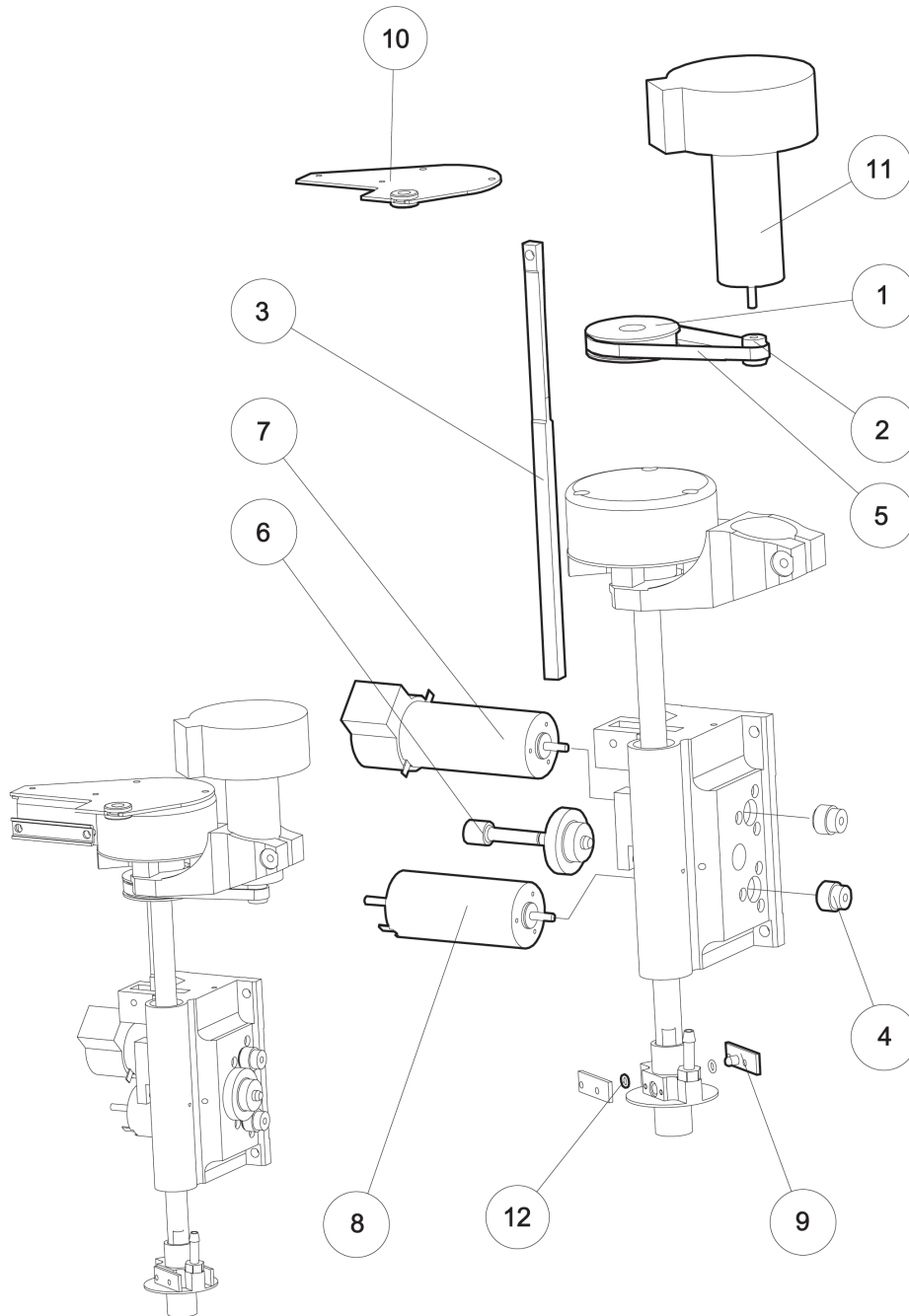

### Belt pulley Z-Fi axle



**Position:** 1

**Type of part:**  
Cog wheel

**Part is replacing:**  
D-012-0114B-4

#### Description

Yellow anodized Fi- movement belt pulley.

#### Machine type:

MY12 , MY15 , MY19 , MY9 , TP11 , TP12 , TP18 , TP9-1 , TP9-2 , TP9-3 , TP9-4

Part no.	Product name
D-012-0717-4	Belt pulley Z-Fi axle

### Belt pulley Fi-motor

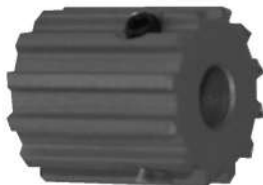

**Position:** 2

**Type of part:**  
Cog wheel

**Part is replacing:**  
D-012-0222-3

#### Description

Yellow anodized belt pulley for Fi- movement.

#### Machine type:

MY12 , MY15 , MY19 , MY9 , TP11 , TP12 , TP18 , TP9-1 , TP9-2 , TP9-3 , TP9-4

#### Requirements:

Z-Fi unit.

Part no.	Product name
D-012-0718-3	Belt pulley Fi-motor

### Rack for Z-Fi drive



**Position:** 3

**Type of part:**  
Mechanical component

#### Description

Rack for Z- movement.

#### Machine type:

MY12 , MY15 , MY19 , MY9 , TP11 , TP12 , TP18 , TP9-3 , TP9-4

Part no.	Product name
D-022-0037B-2	Rack for Z-Fi drive

### Cog wheel



**Position:** 4

**Type of part:**  
Cog wheel

#### Description

Cogwheel for Z-motor.

#### Machine type:

TP9-3 , TP9-4 , TP11 , TP12 , TP18 , MY9 , MY12 , MY15 , MY19

#### Requirements:

Z-Fi unit

Part no.	Product name
D-022-0049-4	Cog wheel

### Belt T2.5/177.5 B=5



**Position:** 5

**Type of part:**  
Belt

#### Description

Fi-axis belt.

#### Machine type:

TP9-3 , TP9-4 , TP11 , TP12 , TP18 , MY9 , MY12 , MY15 , MY19

#### Requirements:

Z-Fi unit.

Part no.	Product name
K-022-0007	Belt T2.5/177.5 B=5

## Z-middle axis complete



**Position:** 6  
**Type of part:** Unit  
**Part is replacing:** L-022-0004

**Description**  
 Special tool (D-007-0016-3) is required when exchanging this part.

**Machine type:**  
 MY19, TP11, TP12, TP18, TP9-3, TP9-4

**Requirements:**  
 For Z-Fi unit - L-022-0050 and L-022-0066.

Part no.	Product name
L-022-0073	Z-middle axis complete

Part no.	Product name
L-029-0158	Z-motor 2

## Vacuum tube with Z-sensor



**Position:** 9  
**Type of part:** Cable  
**Part is replacing:** L-029-0199

**Description**  
 Vacuum tube for Z-Fi unit. 2 pcs M-0943 - O-ring 3.0 X 1.0 and installation instruction included.

**Machine type:**  
 MY12, MY15, MY19, MY9, TP11, TP12, TP18, TP9-3, TP9-4

Part no.	Product name
L-029-0199B	Vacuum tube with Z-sensor

## Z-motor 1 with encoder



**Position:** 7  
**Type of part:** Motor  
**Part is replacing:** L-029-0157

**Machine type:**  
 MY12, MY15, MY19, MY9, TP11, TP12, TP18, TP9-3, TP9-4

Part no.	Product name
L-029-0157B	Z-motor 1 with encoder

## FMB Fi motor board

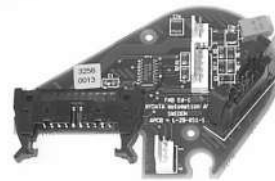

**Position:** 10  
**Type of part:** PCB

**Machine type:**  
 MY12, MY15, MY19, MY9, TP11, TP12, TP18, TP9-3, TP9-4

Part no.	Product name
L-029-0051-1	FMB Fi motor board

## Z-motor 2



**Position:** 8  
**Type of part:** Motor

**Machine type:**  
 MY12, MY15, MY19, MY9, TP11, TP12, TP18, TP9-3, TP9-4

## Fi motor with encoder



**Position:** 11  
**Type of part:** Motor  
**Part is replacing:** L-029-0204B

**Machine type:**  
 MY12, MY15, MY19, MY9, TP11, TP12, TP18, TP9-3, TP9-4

Part no.	Product name
L-029-0204C	Fi motor with encoder

### O-ring 3.0x1.0



**Position:** 12

**Type of part:**  
Miscellaneous

#### Description

For Z-sesor cable - L-029-0199B.

#### Machine type:

MY12 , MY15 , MY19 , MY9 , TP11 , TP12 , TP18 , TP9-1 , TP9-2 , TP9-3 , TP9-4

Part no.	Product name
M-0943	O-ring 3.0x1.0

### Z-lock reinforcement

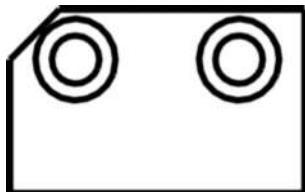

**Position:** 13

**Type of part:**  
Mechanical component

#### Description

Plate on Z-Fi unit that rests on the Z-lock solenoid.

#### Machine type:

MY12 , MY15 , MY19 , MY9 , TP11 , TP12 , TP18 , TP9-3 , TP9-4

Part no.	Product name
D-022-0102B-4	Z-lock reinforcement

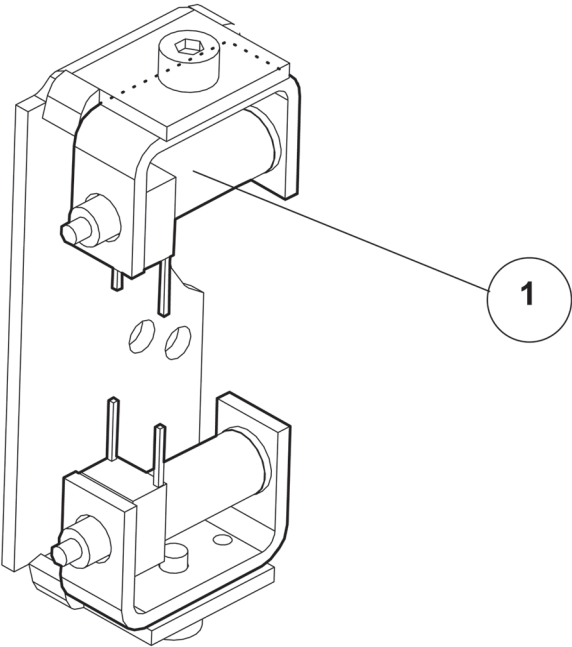

**Z-lock cable with solenoids**



**Position:** 1

**Type of part:**  
Cable

**Part is replacing:**  
L-029-0191

**Machine type:**  
MY12, MY15, MY19, MY9, TP11, TP12, TP18, TP9-1, TP9-2, TP9-3, TP9-4

**Requirements:**  
TP9-1 and TP9-2 has to be upgraded with L-019-0100B before using this Z-lock.

Part no.	Product name
L-029-0191B	Z-lock cable with solenoids

**Machine type:**  
TP9-1, TP9-2, Magazine

Part no.	Product name
K-012-0002	Belt T2.5/120 B=6

**Vacuum tube with cable**



**Type of part:**  
Cable

**Part is replacing:**  
L-012-0073

**Machine type:**  
TP9-1, TP9-2

Part no.	Product name
L-012-0073B	Vacuum tube with cable

**Z-Fi unit**



Part no.	Product name
L-012-0037B	Z-Fi unit complete
L-012-0056B	Z-Fi unit without motors

**XFiM Fi motor cable**

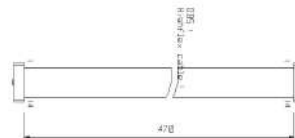

**Type of part:**  
Cable

**Description**  
Cable from Fi-motor to XWB(x) board.

**Machine type:**  
TP9-1, TP9-2

Part no.	Product name
L-019-0204C	XFiM Fi motor cable

**Belt T2.5/120 B=6**



**Type of part:**  
Belt

**Part is replacing:**  
K-014-0002

**Description**  
For Fi axis, 270, 450 & 420PT conveyors.

**XZFG Z-Fi ground cable**



**Type of part:**  
Cable

**Machine type:**  
MY12, MY15, MY19, MY9, TP11, TP12, TP18, TP9-3, TP9-4

Part no.	Product name
L-029-0409	XZFG Z-Fi ground cable

**XZH Z-lock cable with bracket**



**Type of part:**  
Cable

**Part is replacing:**  
L-019-0100

**Description**  
After upgrading with L-019-0100B use L-029-0191B for future replacement of Z-lock cable.

**Machine type:**  
TP9-1 , TP9-2

Part no.	Product name
L-019-0100B	XZH Z-lock cable with bracket

**Cogwheel 18 teeth**



**Type of part:**  
Cog wheel

**Description**  
For Z-motor.

**Machine type:**  
TP9-1 , TP9-2

Part no.	Product name
D-012-0049-4	Cogwheel 18 teeth

**Photo detector IR**



**Type of part:**  
Electrical component

**Description**  
Type A for Z-sensor.  
This is often blue , but it can also be transparent.

**Machine type:**  
TP9-1 , TP9-2

Part no.	Product name
E-040-0030	Photo detector IR

**Photo diode IR**



**Type of part:**  
Electrical component

**Description**  
Type A for Z-sensor.  
This diode is yellow.

**Machine type:**  
TP9-1 , TP9-2

Part no.	Product name
E-040-0031	Photo diode IR

**Rack for Z-drive**



**Type of part:**  
Mechanical component

**Description**  
Rack for z-movement on Z-Fi unit.

**Machine type:**  
TP9-1 , TP9-2

Part no.	Product name
D-012-0045B-3	Rack for Z-drive



### Z-gear shaft



**Type of part:**  
Mechanical component

**Machine type:**  
TP9-1 , TP9-2

Part no.	Product name
L-012-0043	Z-gear shaft

### Z-head washer



**Type of part:**  
Mechanical component

**Description**

Prevents reflection from the X Wagon to enter the vision camera when centering vision components.

**Machine type:**  
TP9-1 , TP9-2

**Requirements:**  
Required when using vision camera.

Part no.	Product name
D-012-0424-4	Z-head washer

### Hydraulic oil



**Type of part:**  
Miscellaneous

**Part is replacing:**  
K-012-0085

**Description**

To be used when lubricating tool, Z-axle, C-axles and Y-rails.

Type: Shell Tellus oil

**Machine type:**

MY12 , MY15 , MY19 , MY9 , TP11 , TP12 , TP18 , TP9-1 , TP9-2 , TP9-3 , TP9-4

Part no.	Product name
L-012-0122	Hydraulic oil

### Fi motor with encoder



**Type of part:**  
Motor

**Part is replacing:**  
L-019-0007B

**Machine type:**  
TP9-1 , TP9-2

Part no.	Product name
L-019-0007C	Fi motor with encoder

### Z motor with encoder



**Type of part:**  
Motor

**Part is replacing:**  
L-019-0004

**Description**

Z-motor or glue pot rotation motor on Glue Station 2.

**Machine type:**  
TP9-1 , TP9-2

**Requirements:**  
XWB ed. 4 or later version.

Part no.	Product name
L-019-0004B	Z motor with encoder

## Part Number Index

Part no.	Product name	Page	Part no.	Product name	Page
D-007-0016-3	Assembly tool for Z-mid. axle	170	D-014-1077-4	Axle reel holder	106
D-007-0018-3	Adjustment tool steering wheel	169	D-014-1132-4	Support spring Flex	110
D-007-0019-3	Adjustment tool, smaller	169	D-014-1812	Hub	108
D-011-0025-3	Magazine guide right/left	109	D-014-1813	Feeder wheel	107
D-011-0034-4	Inspection window	118	D-014-1826	Cover tape ruler, long	107
D-011-0039-4	Inspection window, middle TP11	118	D-014-1827	Cover tape ruler, short	107
D-011-0048-4	Guide pin	108	D-015-0239-3	Belt pulley	41
D-011-0083-4	X-rail profile, lower	228	D-015-0240-3	Belt pulley	41
D-011-0087-3	X-rail profile, upper	228	D-015-0248-4	Belt pulley	41
D-011-0140-4	Position guide - male	109	D-015-0256-2	Card edge holder, conveyor	49
D-011-0158C-3	Optical centering shadow frame	202	D-015-0675-3	Illumination cover	127
D-011-0166-4	Ground pin for X-belt	227	D-015-0774-2	Plexiglass cover - 288 front	242
D-012-0045B-3	Rack for Z-drive	254	D-015-0886-2	Plexiglass cover - 468 front	50
D-012-0049-4	Cogwheel 18 teeth	254	D-015-1406	Spring Tool Bank PT	124
D-012-0158B-4	Assembly-jig O-rings	170	D-015-1409	Spring Tool Bank	124
D-012-0248D	Tool tip B23, Black PEEK	155	D-015-1552	SHIMS 3	124
D-012-0255D	Tool tip B24, Black PEEK	156	D-015-1553	SHIMS 2	124
D-012-0263D-4	Tool tip A12, PEEK	154	D-015-1554	SHIMS 1	124
D-012-0270-4	X-rail cleaner	231	D-015-1738	Plate Assistant	129
D-012-0282B-4	Tool tip C14, Black PEEK	156	D-015-1851	Bracket	48
D-012-0284-4	Tool tip MELF 7.7	157	D-019-0377D-4	Calibration plate	166
D-012-0308C	Tool tip A34, Black PEEK	155	D-021-0072-4	Inspection window, inner TP12	118
D-012-0404C	Tool tip B34, Black PEEK	156	D-021-0073-4	Inspection window, inner TP18	118
D-012-0408B	Tool tip A14, Black PEEK	154	D-021-0074-4	Inspection window, outer	118
D-012-0424-4	Z-head washer	255	D-021-0223-4	Diffusor pyramid optical cent.	201
D-012-0428-3	Centering unit cover, bottom	7	D-021-0248-4	End stop	225
D-012-0717-4	Belt pulley Z-Fi axle	249	D-022-0013B-3	Axle C-60 centering device	6
D-012-0718-3	Belt pulley Fi-motor	249	D-022-0037B-2	Rack for Z-Fi drive	249
D-012-0857	Tool tip MELF 3.3	157	D-022-0049-4	Cog wheel	249
D-012-0879	Tool tip MELF 4.5	157	D-022-0102B-4	Z-lock reinforcement	251
D-012-0898	Reflex protection Z Wagon	127	D-022-0121-3	Drive wheel C-60	6
D-012-0931	Retainer tool	171	D-022-0122-3	Steel belt cover C-60	6
D-012-1162	Tool tip A13	154	D-024-0118-3	Slide strip, TEX	185
D-013-0019-4	Middle belt pulley	219	D-024-0148-3	Cog wheel, TEX Mother Unit	182
D-013-0172-3	Transducer bracket	227	D-024-0160-3	Rack, TEX Mother Unit	184
D-014-0026B-4	Slide shoe	110	D-025-0062-2	Card edge holder	48
D-014-0097-4	Belt pulley	71	D-025-0195B-2	Card edge holder	49
D-014-0482-4	Holder spring	108	D-025-0211B-3	Board lock arm Conveyor	48
D-014-0507B-4	Hub for TM8 uncover roller	108	D-025-0216-4	Valve Rocker arm	51
D-014-0615-4	Belt pulley T2.5/24 B=10	73	D-025-0488B	Retainer board spring	50
D-014-0617-3	Brake-disc for feeder wheel	81	D-025-0523	Bracket for Sunx sensor	36
D-014-0659-4	Loading spring	109	D-025-0524	Long bracker for SUNX sensor	36
D-014-0664-4	Handle	65	D-041-0141	Tempered glass 5X	121
D-014-0666-3	Sliding list, container	110	D-041-0142	Tempered glass 9X	121
D-014-0675-4	Magazine container bar	109	D-041-0280	Tempered glass 3X	121
D-014-0683-4	Sliding list bottom plate	110	D-041-0323	Tempered glass 12X	120
D-014-0685-2	Tape guide plate	95	D-045-0064	Pin guide	50
D-014-0685B-2	Tape guide plate	95	D-045-0628	Square axle	51
D-014-0698-4	Outflow spring	109	E-011-0010	Safety switch	117
D-014-0707-4	Cogwheel 50 teeth, plastic	123	E-011-0011	Safety switch plate	116
D-014-0708-4	Cogwheel 15 teeth, plastic	122	E-011-0011	Safety switch plate	116
D-014-0723B-4	Cover glue station	123	E-011-0012	Safety switch contact block	116
D-014-0769-4	Bracket, module Flex feeder	107	E-011-0012	Safety switch contact block	116
D-014-0774-3	Shaft lower Flex magazine	109	E-011-0013	Safety switch contact block	116
D-014-0819-4	Magazine ref.point sticker 1*5	111	E-011-0013	Safety switch contact block	116
D-014-0849-4	Plastic axle	65	E-011-0014	Safety switch extension clip	118
D-014-0851-2	Feeder wheel TM8FC	81	E-011-0019	Membrane push button	42
D-014-0852-2	Feeder wheel	81	E-011-0026	Safety Button	116
D-014-0853B-3	Spacer for TM8C feeder wheel	82	E-011-0026	Safety Button	116
D-014-0858-3	Spacer for TM12C feeder wheel	81	E-011-0049	Main Switch 3-pole	117
D-014-0859-3	Spacer for TM16C feeder wheel	82	E-013-0003	Relay 220V AC 2VX	160
D-014-0860-3	Spacer for TM24C feeder wheel	82	E-013-0015	Relay emergency stop 24V	221
D-014-0915-4	Cover tube	107	E-013-0017	Relay emergency stop 24V	161
D-014-0961-4	Axle spindle uncover wheel arm	106	E-013-0102B	Power relay	160
D-014-1057-3	Spacer for TM24D feeder wheel	82	E-040-0030	Photo detector IR	254

## Part Number Index

Part no.	Product name	Page	Part no.	Product name	Page
E-040-0031	Photo diode IR	254	K-015-0004	Belt T2.5/950 B=18	238
E-040-0050	LAMP 24, 3W BA155	152	K-015-0008	Nylon wheel for X and Y	230
E-040-0100	Lamp 12V, 20W	221	K-015-0011-R	Board transport belt T2.5/1300 B=4	38
E-040-0102	Lamp 12V, 3W	211	K-015-0023	Belt T5/finite B=20 cord 0.48	238
E-040-0159	SUNX EX14A reflex sensor	43	K-015-0028-R	Bearing housing Y Wagon	242
E-041-0232	Fuse ultra fast 1/16 A (pico)	30	K-015-0028-R	Bearing housing Y Wagon	242
E-041-0240	Fuse ultra-fast 1.5 A (pico)	30	K-015-0029	Flexible joint 8/10	242
E-041-0245	Fuse ultra fast 4 A (pico)	30	K-015-0032	Belt T2.5/145 B=6	36
E-053-0001	Battery Hitachi 10 Ah 6 V	160	K-015-0037	Belt T2.5/650 B=6	37
E-053-0002	BATTERY 12V 7AH, UPS 151X65X94	160	K-015-0038	Belt T5/1100 B=6	37
E-991-0005	DC/DC converter without cables	20	K-015-0039	Nylon cord	51
E-992-0005	Fan 120x120 24V 5W	117	K-015-0055	Shaft coupling 12/14	243
E-992-0010	Fan 119x119x38 160 m3/h 110V	119	K-015-0058	Shaft coupling	243
E-992-0011	Fan 172x150x38 330 m3/h 110V	117	K-015-0084	Safety switch for hood	240
E-992-0015	Fan axial 80x80x38 230V	220	K-015-0090	Damper	243
K-010-0016	Diskette 25/2D 5.25"	24	K-015-0091	Grease Tube Retinax EP 2	229
K-010-0042	Printer Fujitsu DL3700	153	K-017-0051	Relay type 55.34	137
K-010-0045	Ink ribbon Fujitsu DL3700	152	K-017-0052	DC-motor 24V	141
K-010-0344	Parallel Port to SCSI cable	15	K-017-0053	Transport belt diameter 4mm	133
K-010-0352	LIE5 spacer 0.6mm	170	K-017-0054	DC-motor 12V 40 rpm	141
K-011-0010	Component reject bin	225	K-017-0055	DC-motor 24V elevator	141
K-011-0018	Lens Eritec 1.3/8mm	202	K-017-0056	Cassette transport belt, lower	132
K-011-0027	Air spring, hood	111	K-017-0057	Cassette transport belt, upper	133
K-011-0028	Air spring, hood	224	K-017-0058	Cassette transport belt	132
K-011-0051	Filter ZFF 250	120	K-017-0059	Relay type 40.52	137
K-011-0052B	Filter fan ZFF250/115VAC	120	K-017-0060	Magnetic valve 3-1/8	132
K-012-0002	Belt T2.5/120 B=6	253	K-017-0061	Magnetic valve 5/18	132
K-012-0002	Belt T2.5/120 B=6	253	K-017-0062	Pusher Loader	139
K-012-0002	Belt T2.5/120 B=6	253	K-017-0063	Pusher Unloader	139
K-012-0009	Membrane for pump, 5002, 12VDC	197	K-017-0063B	Pusher Unloader	139
K-012-0013	Rubber cloth 40 x 40 x 1 mm	127	K-017-0064	DC motor 12V 80rpm for BC	142
K-012-0015	Holder for vacuum filter	196	K-017-0065	Cassette holder, lower	132
K-012-0016	Vacuum filter	198	K-017-0066	Cassette holder, upper	132
K-012-0018	Tube connector, T-40-1	198	K-017-0067	Slot sensor for index bar	138
K-012-0019	Tube connector, T-230-1	197	K-017-0068	Amplifier for slot sensor	135
K-012-0024	Nipple, straight	197	K-017-0069	Endpoint switch for elevator	135
K-012-0028	Pressure tank	197	K-017-0070	PUB motor control 2405A	136
K-012-0030B	Silicon tube 3.5x8	198	K-017-0071	PUB motor control 2410A	136
K-012-0031	Vacuum tank	198	K-017-0072	Safety reflex sensor	137
K-012-0055	Grease cartridge, cabled	207	K-017-0073	Reflector plate	139
K-012-0058	Isolator	191	K-017-0074	Adjustable foot	138
K-012-0084	Vacuum valve (MAC)	191	K-017-0079	Grooved nut M6 for Alu-profile	139
K-012-0108	Vacuum filter HYDRA 100-pcs	128	K-017-0080	Grooved nut M8 for Alu-profile	139
K-012-0109	Oiler, HYDRA	127	K-017-0085	Stepper motor with brake	143
K-012-0122B	Grease tube 25g	127	K-017-0086	Sensor WT170-P112	138
K-013-0003	Belt T2.5/380 B=20	212	K-017-0087	Sensor WT150-P162	137
K-013-0014	Grease paste	229	K-017-0088	Transport Belt GT6 19*2050	133
K-013-0014	Grease paste	229	K-017-0089	Transport Belt GT6 19*3050	134
K-013-0021	Flexible joint X-motor	226	K-017-0090	Transport Belt GT6 19*3650	134
K-013-0023	X-belt	212	K-017-0091	Transport Belt GT6 19*4650	135
K-013-0025	Flexible joint 14/19	225	K-017-0092	Transport Belt GT6 19*5650	135
K-013-0025	Flexible joint 14/19	225	K-017-0093	Transport Belt GT6 19*1850	133
K-013-0026	X-belt motor	231	K-017-0094	Transport Belt GT6 19*2450	134
K-013-0028	Grease paste for X-rail	229	K-017-0095	Transport Belt GT6 19*3450	134
K-013-0031B	X-belt motor	231	K-017-0096	Transport Belt GT6 19*4450	135
K-013-0032	X-belt	212	K-017-0097	Transport Belt GT6 19*2200	134
K-013-0035	Shock arbsorber Weforma	230	K-017-0098	Transport Belt TT5/1-HC 18*2580	135
K-013-0036	Flexible joint DKN 15/26	226	K-017-0104	Switch with light	138
K-014-0008	Feeder solenoid TM 1*	69	K-017-0106	Stepper motor controller board	43
K-014-0012B	Vibrator	101	K-017-0108	DC motor 24V 130RPM	142
K-014-0022	Belt T2.5/145 B=3	73	K-017-0109	DC motor 12V 80RPM	142
K-014-0024	Belt T2.5/317.5 B=4	71	K-017-0110	DC motor 24V 40RPM	142
K-014-0037-R	Feeder solenoid TM 8	69	K-017-0111	DC motor 24V 80RPM	142
K-014-0065	Belt AT3/150 W=3	97	K-017-0163	Belt Transport/Buffer	132
K-015-0002	Belt T2.5/285 B=6	238	K-017-0164	Motor (external conveyor)	143

## Part Number Index

Part no.	Product name	Page	Part no.	Product name	Page
K-017-0165	Photo switch	136	K-025-0015	Belt T5/920 B=6	37
K-017-0166	Cam follower	139	K-025-0016	Belt T2.5/540 B=6	37
K-017-0167	Signal interface	141	K-025-0018	Magnetic strip	111
K-017-0168	Relay	137	K-029-0015	ELMO Servo amplifier	220
K-017-0169	Transformer	138	K-029-0016	Elmo power supply board	220
K-017-0176	Motor M22 width adjustment	143	K-029-0017	ELMO Motherboard 1	220
K-017-0177	Rocker switch, E56-SW-2	140	K-029-0018	ELMO Motherboard 2	220
K-017-0178	Selector switch, E56-SW-4.4	141	K-029-0035	Carbon Brush for F12 M4	228
K-017-0179	Motor controller, E51-U-5	140	K-031-0005B	DVD-rom drive SCSI	24
K-017-0180	FXOS-14MT-DSS PLC,E53-PLC-10	140	K-035-0067	Scale cleaning wipes	51
K-017-0181	FXOS-20MT-DSS PLC,E53-PLC-11	140	K-040-0132	Drum OKI 14i	153
K-017-0208	Motor	142	K-040-0133	Toner OKI 14i	153
K-017-0219	Valve monst.	143	K-040-0194	Toner for OKI B4300/B4350	153
K-017-0224	Cylinder in pusher	140	K-040-0195	Drum for OKI B4300/B4350	152
K-017-0275	Drive belt Conveyor/Destacker	133	K-040-0196	Postscript DIMM	153
K-017-0367	Photo switch	136	K-040-0215	LCD Monitor	24
K-019-0003B	Network card SMC Lanet16C	29	K-041-0017	Component reject bin	119
K-019-0018	Keyboard US	21	K-041-0021	Washer 0.2 mm	97
K-019-0022	Disc Oldham coupling	195	K-041-0022	Washer 0.025 mm	97
K-019-0113	Disk drive for TP9	23	K-042-0001	Guide wheel, fixed, X wagon	227
K-019-0130	Run-time clock 220V 50Hz	158	K-042-0018	Flexible joint DKN 4/21	229
K-019-0130-B	Run-time clock 117V, 60Hz	158	K-043-0004B	Flexible joint DKN20/30 spec	226
K-019-0147	Monitor 12" monochrome	33	K-043-0007	Shock absorber Weforma	120
K-019-0161B	PC disk drive 5 1/4"	21	K-043-0010	Shock absorber Weforma	230
K-019-0166	Frame grabber board	27	K-045-0039	Sensor lens FU-12	51
K-019-0170	Video camera, Sony CCD XC-77CE	211	K-049-0006	SCSI Board	29
K-019-0170B	Video camera, CCD XC-77BBCE	201	K-049-0009	IDE to SCSI Converter	14
K-019-0187B	Video Multi-plexer	29	L-007-0002	Tool for motor exchange, C-60	171
K-019-0189	Multi-port serial board	29	L-007-0003	Tool for steel-belt exchange	171
K-019-0190	Multi-port serial board cable	15	L-007-0005	Reference magazine	171
K-019-0197F	Hard disk	24	L-010-0030F	Spare Part Set 1F TP9-1/TP9-2	174
K-019-0207	Printer cable	152	L-010-0330B	Spare Part Set 1B TP9/11-UFP	175
K-019-0210B	VGA Video board	29	L-010-0347B	CD-ROM kit SCSI	22
K-019-0222	Run-time clock	161	L-010-0360	Spare Part Set 1 TP9/11-UFP	175
K-019-0276	Mains input cable US standard	159	L-010-0361	Spare Part Set 1 TP9-2U	174
K-019-0337	Mains input cable Euro standard	159	L-010-0420	Linear encoder head	204
K-019-0343C	Disc Drive 3.5" Sony	23	L-010-0421	Linear encoder codestrip	202
K-019-0348	Memory 32MEG EDO 60NS SIMM	24	L-010-0422	Gauge - Line Scan Camera	202
K-019-0360	Disc Oldham coupling	195	L-010-0425	Window holder	203
K-019-0372	Cordset IEC-US 7m	158	L-010-0428	LVS reference background, C60	202
K-019-0384	Trackball	11	L-010-0450	Linescan Camera box	204
K-019-0389	Monitor RGB	34	L-010-0452B	Calibration plate	168
K-021-0003	Fan 80x80x32	117	L-010-0708	Spare part kit Membrane Pump	196
K-021-0019	Lock with key	120	L-010-0709	Spare part kit Tandem Pump	196
K-021-0025	Filter cloth	120	L-010-0734D	TPSys 2.0 software kit	172
K-022-0002	Fan, X Wagon motor	228	L-010-0748B	TPSys 2.1 software kit	172
K-022-0003	Guide wheel, X Wagon	227	L-010-0795E	TPSys 2.2 software kit	172
K-022-0007	Belt T2.5/177.5 B=5	250	L-010-0806	Ruler with reference line	203
K-022-0022	Assembly sheave	225	L-010-0810D	TPSys 2.3.4 software kit	172
K-022-0023	Flexible joint 6x6	229	L-010-0849	TPSys 2.4 software kit	172
K-022-0024	Flexible joint (3x4) TE	184	L-010-0868	TPSys 2.5 software kit	172
K-022-0042	Brushes, Set of 4	149	L-012-0006C	Centering unit complete	9
K-023-0001	Flexible joint 19x24	226	L-012-0037B	Z-Fi unit complete	253
K-023-0005	Flexible joint 6/10	226	L-012-0043	Z-gear shaft	255
K-023-0013	Pump unit , green	227	L-012-0049B	Lens for X-camera complete	211
K-023-0026	Kevlar rope 3mm	230	L-012-0054	Retrofit XWB3 + motors	237
K-024-0009	Reflex tape	112	L-012-0055	C-motor with console	8
K-024-0012	Flexible joint 3/4	108	L-012-0056B	Z-Fi unit without motors	253
K-024-0015	Flexible joint 8/8	183	L-012-0057	Steel belt centering upgrade	9
K-024-0026	Cogbelt TEX Shuttle Unit	178	L-012-0058	Centering axle bearing	7
K-024-0032	Runner 6*19	184	L-012-0073B	Vacuum tube with cable	253
K-024-0034	Rail guide, TEX Mother Unit	184	L-012-0074	Upgrade X Wagon camera	207
K-024-0037	Spring Clip, TEX Cassette	110	L-012-0099	Pressure reducing valve	198
K-025-0007	Belt T10/1700 B=10	178	L-012-0100	Upgrade for membrane pump	199
K-025-0014	Belt T2.5/200 B=6	36	L-012-0101	Upgrade for membrane pump	198

## Part Number Index

Part no.	Product name	Page	Part no.	Product name	Page
L-012-0104	Vacuum filters and tubes	196	L-014-0122	Bottom plate, magazine feeder unit complete	65
L-012-0121	Lamp housing X Wagon camera 2	236	L-014-0124	Support beam complete	93
L-012-0122	Hydraulic oil	255	L-014-0125	Cover plate complete	95
L-012-0131	HYDRA adjustment tool	170	L-014-0128	Feeder number bar TM8C	65
L-012-0133	Centering steel belt repair kit	7	L-014-0138	Uncover wheel arm TM12C,16C	77
L-012-0291	HYDRA theta-belt spare part kit	124	L-014-0140	Uncover wheel arm TM24D	77
L-012-0364	HYDRA Tool D=2.6	126	L-014-0141	Uncover wheel TM12C	78
L-012-0370	Upgrade kit vacuum valve	193	L-014-0142	Uncover wheel TM16C	78
L-012-0378	Tool Tip HYDRA, 10-pcs	126	L-014-0143	Uncover wheel TM24D	78
L-012-0381B	Tool tip C23S	156	L-014-0175	Container for tape reels TM12C	61
L-012-0388	HYDRA mylar belt spare part kit	124	L-014-0176	Container for tape reels TM16C	61
L-012-0433	HYDRA Tool	126	L-014-0177	Container for tape reels TM1216C	61
L-012-0436	Solenoid complete HYDRA	130	L-014-0178	Container for tape reels TM24D	61
L-012-0440B	Theta motor unit	128	L-014-0214	Tape holder arm TM12C	85
L-012-0509B	Reference points complete type 14	127	L-014-0215	Tape holder arm TM16C	85
L-012-0512	Tool, Exchangeable, set of 8	126	L-014-0216	Tape holder arm TM24D	85
L-012-0522	Stops, spare part kit	126	L-014-0217	Slit plate complete TM12C	96
L-012-0540	Tool tip A23S	155	L-014-0218	Slit plate complete TM16C	96
L-012-0542	Tool tip A24S	155	L-014-0219	Slit plate complete TM1216C	95
L-012-0550	Reference points complete type 23	129	L-014-0220	Slit plate complete TM24D	95
L-012-0553B	O-ring package	126	L-014-0221	Feeder number bar TM12C	65
L-012-0576	Tool H04 spare tips	127	L-014-0229	Eccentric bushing, left	88
L-012-0609	Vacuum Unit	130	L-014-0230	Eccentric bushing, right	87
L-012-0614	Fastener kit HYDRA 2D	125	L-014-0251	Feeder wheel 12mm	96
L-012-0622	Thin components in box	24	L-014-0252	Feeder wheel 16mm	96
L-012-0623	O-ring mounter kit	171	L-014-0275D	Feeder spring console complete	113
L-012-0628	Vacuum filter pack	128	L-014-0279	Uncover wheel arm TM32D	111
L-012-0633	Calibration components	168	L-014-0279	Uncover wheel arm TM32D	111
L-012-0634	Area calibration plate	167	L-014-0280	Uncover wheel TM32D	78
L-012-0711	HYDRA 2D MY Refurbished	124	L-014-0289	Container for tape reels TM32D	61
L-012-0712	HYDRA 2D TP Refurbished	124	L-014-0299	Feeder arm, Fine Pitch	87
L-012-0713	HYDRA 2D MY Spare Part	124	L-014-0300	Feeder arm, Fine Pitch	87
L-012-0809	Upgrade HZ motor Hydra	128	L-014-0307	Side Plate Flex Magazine - Left	65
L-012-0815	X-wagon camera spare part kit	209	L-014-0308	Side Plate Flex Magazine - Right	66
L-012-0823	Set of 3 C14 tool tips	154	L-014-0404	Uncover wheel arm, Flex 12mm	97
L-012-0852	Nylon wheel	230	L-014-0405	Uncover wheel, Flex 12mm	97
L-012-0853	HZ-motor unit	128	L-014-0407	Uncover wheel arm, Flex 8mm	97
L-012-0858	Latch washer set of 10	125	L-014-0408	Outflow plate TMD Flex/TM8FC magazine	95
L-012-0860	Omega 28 tube 15g	157	L-014-0409	Uncover wheel arm, Flex 16mm	97
L-012-0885	Set of 3 B12 tool tips	154	L-014-0427	Uncover wheel arm, Flex 24 mm	97
L-013-0013C	X-belt bearing housing, right	228	L-014-0430	Uncover wheel, Flex 24mm	97
L-013-0014C	X-belt bearing housing, left	227	L-014-0431	Tape holder arm, Flex 12mm	97
L-013-0015	Cable wagon complete TP9-1/2	211	L-014-0443D	Container for tape reels TMD Flex	62
L-013-0016B	Upgrade X axis to single belt	237	L-014-0445	Component separator spring TM8FC	85
L-013-0019	Antistatic roller, cable wagon	224	L-014-0446	Tape holder arm TM8FC	85
L-013-0113	X-belt motor with transducer	237	L-014-0449	Container for tape reels TM8FC	62
L-013-0115	Cable wagon complete TP9-3	211	L-014-0460	Uncover wheel TM8C, plastic	79
L-013-0120	Cable wagon complete TP11	211	L-014-0465	Magazine button and bracket	93
L-013-0127	Cable wagon complete TP9-4	211	L-014-0492	Container for tape reels TM44D	62
L-013-0139	Drive axle with bearings	223	L-014-0502	Tape guide TM5632D	110
L-014-0090C	Solenoid unit TM8C	69	L-014-0503	Slit plate complete TM5632D	96
L-014-0095C	Uncover wheel arm TM8C	77	L-014-0504	Feeder number bar TM5632D	107
L-014-0096	Uncover wheel TM8C	79	L-014-0505	Container for tape reels TM5632D	62
L-014-0098	Feeder motor unit	73	L-014-0510	Uncover wheel arm TM44D	77
L-014-0101	Uncover roller complete	91	L-014-0514	Uncover wheel arm TM56D	77
L-014-0103	Uncover roller coverage	114	L-014-0518	Uncover wheel string	78
L-014-0105	Drive axle complete	87	L-014-0650	Tape holder arm, Flex 32mm	97
L-014-0106C	Feeder arm, standard	87	L-014-0657	Tape holder arm, Flex 56mm	97
L-014-0107C	Feeder arm, drive side	87	L-014-0701	Glue pot with leveling arm	123
L-014-0112	Container for tape reels TM8C	62	L-014-0718	Tape holder arm, Flex 44mm	97
L-014-0113	Slit plate complete TM8C	96	L-014-0804	Uncover wheel TM44D	78
L-014-0114	Tape holder arm TM8C	85	L-014-0805	Uncover wheel TM56D	79
L-014-0115	Hold-down spring complete	113	L-014-0890	Feeder wheel TM32D	101
L-014-0120	Side plate, feeder unit - right	66			
L-014-0121	Side plate, feeder unit - left	66			



## Part Number Index

Part no.	Product name	Page	Part no.	Product name	Page
L-014-0891	Feeder wheel TM44D	101	L-015-1684	Area calibration background 427*461	166
L-014-0892	Feeder wheel TM56D	101	L-015-1685	Area calibration background 440*508	167
L-014-0899	Uncover wheel, Flex 32mm	97	L-015-1686	Area calibration background 563*508	167
L-014-0900	Uncover wheel, Flex 44mm	97	L-015-1687	Area calibration background 736*609	167
L-014-0901	Uncover wheel, Flex 56mm	97	L-015-1688	Area calibration background 914*609	167
L-014-0910	Component separator spring TM8C	85	L-015-1689	Area calibration background 927*732	167
L-014-0911	Tape holder arm, Flex 24mm	97	L-017-0016	In-line adapter sensor	136
L-014-1327	Agilis Interface Parts	103	L-019-0001-4	Computer Box 1	32
L-014-1328	Agilis Drive Unit mount	102	L-019-0004B	Z motor with encoder	255
L-014-1329	Agilis Motor Unit	103	L-019-0004B	Z motor with encoder	255
L-014-1330	Agilis Rear Handle Unit	103	L-019-0006	Mini motor HP servomotor (Y)	244
L-014-1331	Agilis Feeder Wheel Unit	102	L-019-0007C	Fi motor with encoder	255
L-014-1332	Agilis Locking Unit	103	L-019-0009-8	Power supply	164
L-014-1333	Agilis Solenoid Unit	104	L-019-0010	Power transistor kit	224
L-014-1334B	Agilis interconnection board kit - QMFIB	103	L-019-0011-6	Power supply 2	164
L-014-1335	Agilis Eccentric Shaft	102	L-019-0012B	Motor for lead screw Y Wagon	244
L-014-1336	Agilis Y-adjustment Unit	104	L-019-0012B	Motor for lead screw Y Wagon	244
L-014-1337	Agilis Safety Clamp	103	L-019-0021-1D	MS motor & sensor board TM	74
L-014-1338	Agilis Drive Unit Frame	102	L-019-0022-3	Power supply 3	164
L-014-1339	Agilis Waste Shelf	104	L-019-0025-6	YWB Y Wagon board	245
L-014-1341	Agilis Feeder Wheel Set	102	L-019-0029	MOT1 motor control board 1	28
L-014-1364B	Agilis control board - QMC	101	L-019-0030	Intel Pro/100+ spare part	27
L-014-1513	Feeder head kit - ALM8	105	L-019-0037-3D	3PT1, test circuit board	207
L-014-1523	Feeder head kit - ALM1216	104	L-019-0039-4B	VC edition 4B, Vibration Control	113
L-014-1534	Safety clamp - ALM8	106	L-019-0045-2	SKB3 keyboard board	121
L-014-1544	Safety clamp - ALM1216	105	L-019-0049	MI magazine interface board	28
L-014-1545	Feeder head unit - ALM8	105	L-019-0055-1	JFKB joystick full keyboard	33
L-014-1546	Feeder head unit - ALM1216	105	L-019-0056	Network card 3Com 3C905CX-TX-M spare part	23
L-014-1547	Tape support - ALM8	106	L-019-0058	P4-CP2 complete with front	34
L-014-1548	Drive unit	104	L-019-0059C	MI-MOT1 unit	27
L-014-1551	Agilis interconnection board kit - QM16FIB	102	L-019-0063-5C	WSR X-safety switch receiver	234
L-014-1565	Oldham coupling	112	L-019-0065-1	TST ed. 1	233
L-014-1566	Encoder	113	L-019-0067B	WSR cable	213
L-014-1567	Solenoid unit	106	L-019-0068	TST cable	212
L-014-1571	Motor	112	L-019-0071	XCP crude power cable	214
L-014-1573	Rear handle, ALM8	113	L-019-0072	XBOP Booster power cable	214
L-014-1574	Rear handle, ALM1216	113	L-019-0075E	XXWT X Wagon transducer	222
L-014-1603	Rear unit	113	L-019-0077	XBOF Booster flat cable	213
L-014-1621	Waste shelf	114	L-019-0078B	XXW1 cable 50 pole sectioned	217
L-015-0061	Motor, width adjustment	53	L-019-0079B	XXW2 cable 40 pole sectioned	218
L-015-0063	Motor board-transport conveyer	52	L-019-0081C	XTC for belt centering unit	8
L-015-0064	Support plate, conveyor	51	L-019-0081D	Centering electrodes upgrade	7
L-015-0069	Spring holder for conveyor	50	L-019-0083C	Joystick with cable	120
L-015-0070	Expander wheel, conveyor	50	L-019-0084	XTP two/three test cable	7
L-015-0222B	Reel spring for conveyor	54	L-019-0087B	Y-transducer with cable	240
L-015-0326C	Motor with transducer	244	L-019-0092	XPD disk power & data cable	19
L-015-0327	Roller, cable tensioner	245	L-019-0093B	XMIF cable	100
L-015-0395	Grease Gun for X-rail	170	L-019-0094	XMIBOX cable	98
L-015-0397	Grease Gun with Filter for YWU	170	L-019-0095B	XMIBUS cable	98
L-015-0423	Transducer with cables YWU	240	L-019-0096	JFKB full keyboard cable	14
L-015-0431B	HYDRA Camera box	129	L-019-0099	XMF glue cable	122
L-015-0451	Upgrade kit BJS	55	L-019-0100B	XZH Z-lock cable with bracket	254
L-015-0452	BJS calibration plate with label	167	L-019-0102	XCR21 monitor cable TP9-BNC	16
L-015-1576	HYDRA ATE Maintenance kit	125	L-019-0103	XCR22 Monitor cable BNC-BNC	17
L-015-1577	HYDRA 2B ATE upgrade kit	125	L-019-0106B	24V DC motor + gear	73
L-015-1658	HYDRA 2D Maintenance kit	125	L-019-0106B	24V DC motor + gear	73
L-015-1681	Area calibration background 254*456	166	L-019-0106B	24V DC motor + gear	73
L-015-1682	Area calibration background 384*508	166			
L-015-1683	Area calibration background 400*590	166			

## Part Number Index

Part no.	Product name	Page	Part no.	Product name	Page
L-019-0107	Optical calibration plate Hydra Camera	169	L-019-0442	XCCP centering camera cable	214
L-019-0108	Optical calibration plate kit SVC & HRC	169	L-019-0447	Calibration plate	168
L-019-0128	Fuse kit	162	L-019-0450	XXW2A+B 60 pole cable	218
L-019-0131	Printer cable	152	L-019-0455	XXW1-2 50 pole cable	216
L-019-0139	XTF VMF trafo cable	101	L-019-0456	XTF cable	215
L-019-0159	SNB serial number board	21	L-019-0460	XXWT X Wagon transducer	223
L-019-0179C	Machine serial number circuit	21	L-019-0462	X Wagon motor	232
L-019-0182C	X/Y emergency cables	119	L-019-0464	XXME X-motor transducer	222
L-019-0195	X-motor with cogwheel	232	L-019-0470B	XOCP-1 opt. cent. power cable 1	19
L-019-0197-2	TMC tape solenoid con. board	69	L-019-0471	XOCP-2 opt. cent. power cable 2	19
L-019-0204C	XFiM Fi motor cable	253	L-019-0473	XDDP disk drive cable A:5,25	17
L-019-0205	XMS motor & sensor cable	93	L-019-0476-5B	Centering electrodes w/o cable	8
L-019-0206	XDM drive magnets cable	93	L-019-0477	Keyboard extension cable	14
L-019-0214	Digitizer cable	13	L-019-0479	Monitor cable adapter	15
L-019-0214B	Digitizer cable Oce Graphics	13	L-019-0481	RS232 DSUB25M modular 6/6 adapter	12
L-019-0225-6	YC edition 6	54	L-019-0482	RS 232 modular cable	16
L-019-0226-1	SLS	53	L-019-0486-1	TCB	8
L-019-0237B	End-point switch Y-wagon with cable	238	L-019-0487	Fuse kit	162
L-019-0239B	XMFE conveyor cable	40	L-019-0490	XTC electrodes with cables	8
L-019-0241-2A	CP4 without front panel	26	L-019-0493-DA	SKB3 key-tops, Danish	12
L-019-0251	XYWH Y-width end position switch	52	L-019-0493-DU	SKB3 key-tops, Dutch	12
L-019-0252	XFT-board position sensor	18	L-019-0493-EN	SKB3 key-tops, English	12
L-019-0253	XFL board position sensor	39	L-019-0493-FI	SKB3 key-tops, Finnish	12
L-019-0255	Y-conveyor flat cable	41	L-019-0493-FR	SKB3 key-tops, French	12
L-019-0275D	XVS vacuum system cable	196	L-019-0493-GE	SKB3 key-tops, German	12
L-019-0277-3B	FGB frame grabber board	27	L-019-0493-IT	SKB3 key-tops, Italian	13
L-019-0279	Membrane pump complete	191	L-019-0493-NO	SKB3 key-tops, Norwegian	13
L-019-0287	XYCM Y motor extension cable	40	L-019-0493-SP	SKB3 key-tops, Spanish	13
L-019-0291-3	OCL optical centering board	204	L-019-0493-SW	SKB3 key-tops, Swedish	13
L-019-0295B	Y Wagon motor filter box cable	244	L-019-0497B	D9M DSUB9M MODULAR 6/6	12
L-019-0297B	XXWT X-motor transducer	222	L-019-0499B	XOCAT OCL & video cable	19
L-019-0303B	XV4L lamp cable	201	L-019-0500	XYM motor connector cable	181
L-019-0315	XPOA-OCL cable	19	L-019-0505	XGTS connection block cable	40
L-019-0317-1B	ATC AT connector board	25	L-019-0506	WSR2 cable	213
L-019-0322-3	Booster 2 edition 3	235	L-019-0507	XYM motor extension cable	181
L-019-0326B	PC - TP9 25 pole cable	15	L-019-0511B	D9F DSUB-9 F mod. 6/6 straight	12
L-019-0327B	PC - PC 25 pole cable	15	L-019-0512B	D9FX DSUB-9 F mod. 6/6 cross	12
L-019-0328-2	TP9 Calibration board	169	L-019-0513B	D25F DSUB-25 F mod. 6/6 straight	12
L-019-0329	Calibration plate	168	L-019-0514B	D25FX DSUB-25 F mod. 6/6 cross	12
L-019-0381-1	EBM	186	L-019-0519	RGB monitor cable 1	15
L-019-0397	XFAN Fan with cable	24	L-019-0520	RGB monitor cable 2	16
L-019-0403	Conveyor dummy din connector	42	L-019-0521	SMEMA-in, cable	36
L-019-0406	XXW2 cable 40 pole	218	L-019-0522	SMEMA-out, cable	36
L-019-0407	XXW1 cable 50 pole	217	L-019-0525	XXW1-2 50 pole cable	216
L-019-0408	XCP crude power cable	214	L-019-0526	XXW2A+B 60 pole cable	218
L-019-0409	XBOP Booster power cable	214	L-019-0527B	XMIBUS cable	98
L-019-0410	XBOF booster flat cable	213	L-019-0529	XMIBOX cable	98
L-019-0411	XYF Y Wagon flat cable	238	L-019-0544	XBMC belt motor cable	213
L-019-0412	XMF glue cable	122	L-019-0555	Motor membrane pump	195
L-019-0413	XPD disk power & data cable	19	L-019-0588-1B	MPS motherboard power supply	233
L-019-0414	XMIBOX cable	98	L-019-0593	Emergency relay connector	163
L-019-0415	XCR21 Monitor cable TP9-BNC	16	L-019-0618	XXWT X Wagon transducer	223
L-019-0416	XDY diskette cable in Y Wagon	18	L-019-0619B	XXME X-motor transducer	222
L-019-0420A	MY 105B TE serial number PAL	182	L-019-0620	XDDP diskdrive cable	17
L-019-0421-1	TBB tray box board	186	L-019-0624-3	BNB edition 3	235
L-019-0424	XSKB keyboard cable	20	L-019-0625-2B	NREG edition 2B	236
L-019-0426	Conveyor safety adapter cable	38	L-019-0631	XMF glue station adapter cable	122
L-019-0427	Conveyor safety cable (double)	38	L-019-0632	XMF2 glue station cable	122
L-019-0428B	Conveyor safety sensor	39	L-019-0634-2	HYDUBB HYDRA DUB board	129
L-019-0436	Frame grabber cable	13	L-019-0640	Sensor holder model 2	50
L-019-0440	Conveyor safety sensor	42	L-019-0657-2C	ATC2 AT connector board 2	25
L-019-0441	XCLP cent. lamp power cable	201	L-019-0658	XETC ELMO timer cable	215
			L-019-0660-1B	ATI3 AT interconnect board 3	25
			L-019-0667	Contact cover WSR2	236

## Part Number Index

Part no.	Product name	Page	Part no.	Product name	Page
L-019-0668	Fan, HYDRA	124	L-019-1089C	Hard drive WD800 BB	22
L-019-0681	End-position switch rear	239	L-019-1098	AT-CPU2 with CP5	31
L-019-0682	End-position switch, front	239	L-019-1106	UPS for PC server 230VAC	158
L-019-0692	BM3CB with R6 for TP9-4/11	12	L-019-1107	UPS for PC server 120VAC	158
L-019-0704	Disk drive 3.5" mount kit	22	L-019-1109-1	GFIB edition 1, Generic Feeder Interface Board	112
L-019-0709	MOT1 with front panel	28	L-019-1110	VC board for GFI	112
L-019-0710	MI with front panel	33	L-019-1113	Booster spare part kit	235
L-019-0713	Pump motor with cables	195	L-019-1146	Configured MAT915	25
L-019-0714	Tandem vacuum pump	193	L-019-1150	AT-CPU PF2 with CP54 boxed	30
L-019-0719-3	CPP CP5-ISA plug-in board edition 3	26	L-019-1151	AT-CPU2 PF2 with CP54 boxed	31
L-019-0725	XYF2 Y Wagon flat cable 2	239	L-019-1152	AT-CPU2 PF2 with CP5 boxed	31
L-019-0726	XYF2 Y Wagon flat cable 2	239	L-019-1155	Upgrade kit 2.5" HD	34
L-019-0727	XYFA Y wagon cable adapter YWB	239	L-019-1156	Hitachi 5K100 40GB	22
L-019-0730	Board guide rail	23	L-020-0030B	Spare Part Set 1B TP12/18-UFP	175
L-019-0732	XM XO-X6 cable	180	L-022-0002C	Centering unit C60 complete	3
L-019-0732	XM XO-X6 cable	180	L-022-0006	Outer jaw C-60	6
L-019-0734-1	YWB2 Y Wagon board 2	245	L-022-0007	Inner jaw C-60	5
L-019-0750	MI-MOT1 unit with front panel	27	L-022-0008	C60 steel belt repair kit	5
L-019-0753	BM3CB with R6 TP9-2U	12	L-022-0050	Z-Fi unit with motors	247
L-019-0759B	XXWT X-motor transducer	222	L-022-0065B	Z-lock bracket with magnets	247
L-019-0765	XDDP1 diskdrive cable	18	L-022-0065B	Z-lock bracket with magnets	247
L-019-0771	XZBO/80V Z Booster2 80V 1ohm cable	20	L-022-0066	Z-Fi unit without motors	247
L-019-0772	XYBO/80V Y Booster2 80V 0.56 ohm cable	20	L-022-0073	Z-middle axis complete	250
L-019-0777	SMEMA-adapter	39	L-022-0105B	Z-motor, Midas	147
L-019-0778	SMEMA-adapter	39	L-022-0110	Midas, spare part kit	145
L-019-0785	Fan ELMO	221	L-022-0120	Vacuum tube	150
L-019-0801	XDDP diskdrive cable	17	L-022-0136	Vacuum seal spare part kit	149
L-019-0803-3C	CP5 central processor board 5	26	L-022-0137	Silencer spare part kit	149
L-019-0811-2	OCLD edition 2	205	L-023-0003	Drive shaft with bearings	224
L-019-0812-3	HLCC HYDRA LED & Camera cntrl	203	L-023-0004B	Belt tension roller	235
L-019-0813-2	HLB HYDRA LED board	203	L-023-0030	Cable wagon complete TP18	211
L-019-0827-2C	VVG2 edition 2C with 4MB	30	L-023-0033	Cable wagon complete TP12	211
L-019-0831	XYFI Y Wagon flat cable int.	239	L-023-0038	Upgrade kit cable wagon TP18	212
L-019-0837-2B	LSAD edition 2B	203	L-023-0039	Upgrade kit cable wagon TP12	212
L-019-0838-2B	LSLD Ed-2B Linescan LED board	204	L-023-0110	Cable wagon upgrade	223
L-019-0842B	XMFC YWU3 conveyor cable	40	L-024-0028	THS with holder	187
L-019-0843	YMFC conveyor cable	41	L-024-0103	Bearing housing, TEX Shuttle	187
L-019-0845	Conveyor safety sensor	54	L-024-0106	Motor, TEX Shuttle Unit	185
L-019-0862-1	SLS2 ed 1	54	L-024-0108	Shuttle, TEX Shuttle Unit	185
L-019-0865	Smema CPC14P - CPC14P cable	39	L-024-0121	Motor TEX Mother Unit	185
L-019-0866	SMEMA CPC14P dummy connector	42	L-024-0178	TEX Bar codes 16 narrow pallet	178
L-019-0868	LSAD-LSS Multi video cable	200	L-024-0179	TEX Bar codes 16 wide pallet	178
L-019-0869	LSPW-LSS power cable	200	L-024-0180	Upgrade kit barcode reader	106
L-019-0870	LSAD-LSPW LED control cable	200	L-024-0182	Safety switch for Y-wagon hood and TEX. Not for Pro-Line hoods.	240
L-019-0892-1	HYDB2 HYDRA device board 2	129	L-024-0182	Safety switch for Y-wagon hood and TEX. Not for Pro-Line hoods.	240
L-019-0893-2	HYDUFB2 HYDRA DUF board 2	129	L-024-0188	TEX Barcodes 16 Jedec pallet	178
L-019-0902	Booster BNB/NREG complete	235	L-025-0002	Belt pulley TWM	188
L-019-0909	MDA/VGA cable for BIOS check	14	L-025-0010	Board lock, left	48
L-019-0940	LSAD-VVG2 & LSAD-LSAD cable	200	L-025-0011	Board lock, right	48
L-019-1000	Fuse kit Power Supply	160	L-025-0036	Flywheel TWM	188
L-019-1001	BM3CB with R6 for TP9-4/11 HYDRA	12	L-025-0040B	Support plate	188
L-019-1002	Fuse kit Booster	221	L-025-0042	Glide list	185
L-019-1003	Fuse kit BM3CB	20	L-025-0070	Conveyor bracket model 1	49
L-019-1005-2A	CP4 without front panel	26	L-025-0071	Conveyor bracket TP12/18	49
L-019-1013-2B	OREG edition 2B	236	L-025-0075	Conveyor bracket model 2	49
L-019-1017	MGP card	27	L-025-0078	Locking screw	184
L-019-1020-1C	CP54 edition 1C	26	L-025-0192	Spring package 500T2 special left	45
L-019-1058	Configured CPU-card without VGA	25	L-025-0193	Spring package 500T2 special right	45
L-019-1059	Configured CPU-card with VGA	25	L-025-0194	Spring package 500T2 special left	45
L-019-1083	AT-CPU with CP4	30	L-025-0195	Spring package 500T2 special right	45
L-019-1084	AT-CPU with CP54 for Linux	30	L-029-0003-1B	SKB4 keyboard	121
L-019-1087	AT-CPU2 with CP54 for Linux	31	L-029-0006	SKB4-box cable	118



## Part Number Index

Part no.	Product name	Page	Part no.	Product name	Page
L-029-0007	SKB4-SKB4 cable	118	L-029-0289-3	XNET voltage 200/115V	158
L-029-0011	XXW1-2, XXW3 50 pole cable	217	L-029-0290-1	XNET voltage 220/127V	158
L-029-0012	XXW2-2, XXW4 40 pole cable	217	L-029-0291-1	XNET voltage 410/235V	158
L-029-0024	X Wagon motor	232	L-029-0292-1	XNET voltage 190/110V	158
L-029-0036-5B	WSR2 edition 5B	234	L-029-0293-1	XNET voltage 175/100V	158
L-029-0041	XXFS fan sensor cable	215	L-029-0295-3	XY/D WYE connection	161
L-029-0050B	XDDP diskdrive cable	18	L-029-0296-3	XY/D DELTA connection	161
L-029-0051-1	FMB Fi motor board	250	L-029-0297	XY/D DELTA connection	161
L-029-0055	XYF Y Wagon flat cable	40	L-029-0301B	Computer Box 2	32
L-029-0087-2B	DCRB regulator board	186	L-029-0310-3B	PAIB2	233
L-029-0089	XMFE2 Y Wagon cable	40	L-029-0318-DE	SKB4 key-tops, Danish	13
L-029-0091-2B	PAIB Power amp. interface board	233	L-029-0318-DU	SKB4 key-tops, Dutch	13
L-029-0098	XMIBUS cable, middle	100	L-029-0318-EN	SKB4 key-tops, English	13
L-029-0099	XMIBUS cable left, inner	99	L-029-0318-FI	SKB4 key-tops, Finnish	13
L-029-0100	XMIBUS cable left, outer	99	L-029-0318-FR	SKB4 key-tops, French	13
L-029-0101	XMIBUS cable right, inner	99	L-029-0318-GE	SKB4 key-tops, German	13
L-029-0102	XMIBUS cable right, outer	100	L-029-0318-IT	SKB4 key-tops, Italian	13
L-029-0103	XMIBUS cable left	99	L-029-0318-NO	SKB4 key-tops, Norwegian	13
L-029-0104	XMIBUS cable right	99	L-029-0318-SP	SKB4 key-tops, Spanish	13
L-029-0113-2	Power supply	186	L-029-0318-SW	SKB4 key-tops, Swedish	13
L-029-0119-2	EWB tray elevator board	186	L-029-0319-3	TEXBMCB, TEX BM Con. board	187
L-029-0122-2	OCL2 Optical centering board 2	204	L-029-0320-3	SFB filter board elmobox	233
L-029-0123	Tray contact sensor with cable	179	L-029-0323-3B	TEXZB, TEX Z Board	187
L-029-0124	Tray holder magnet with cable	179	L-029-0334-2	TEXLB, TEX LED Board	187
L-029-0126	Load position sensor	178	L-029-0335-3	TEXYB, TEX Y Board	187
L-029-0127	Unloading position sensor	179	L-029-0344-1	Elmo safety relay	160
L-029-0128	Tray stop solenoids with cable	179	L-029-0347	XDDP disk drive cable	17
L-029-0149	XCMC C-motor cable	6	L-029-0358-2	XNET voltage 110V	158
L-029-0150B	XTC cable	6	L-029-0359-2	XNET voltage 115V	158
L-029-0153	XVC camera cable	215	L-029-0360-3	XNET voltage 125V	158
L-029-0157B	Z-motor 1 with encoder	250	L-029-0361-2	XNET voltage 100V	158
L-029-0158	Z-motor 2	250	L-029-0362-1	XNET voltage 365/210V	158
L-029-0164	XSP safety sensor and switch	180	L-029-0367-3	XSS edition 3	234
L-029-0166	Z-Motor with cable for TE	185	L-029-0371-1E	CMB2 Ed-1E	5
L-029-0175B	Centering electrodes for C60	5	L-029-0379	XBOF Booster Power cable / TEX	179
L-029-0179-4	XMEB edition 4	234	L-029-0380	XBOP Booster Power cable	180
L-029-0180-2	XWMB2	234	L-029-0381	XCP Crude Power cable	180
L-029-0189	Door switch with cable	178	L-029-0382	XTZU cable / TEX	181
L-029-0191B	Z-lock cable with solenoids	253	L-029-0383B	XDSS Door Safety Switch cable	180
L-029-0191B	Z-lock cable with solenoids	253	L-029-0384	XYM TEX Y-Motor cable	181
L-029-0193	XFMB Fi motor board cable	149	L-029-0385	RCYMT TEX RC-unit to Y-motor	183
L-029-0194	XV4L video lamp cable	201	L-029-0386	Inductive encoder / TEX	182
L-029-0195C	XVS vacuum system cable	195	L-029-0388	XTY-Z TEX Y Wagon Z-unit cable	180
L-029-0199B	Vacuum tube with Z-sensor	250	L-029-0391	XLED cable / TEX	180
L-029-0200B	XP2 TST2 sync. cable	215	L-029-0395	Z-Motor and Brake cable / TEX	181
L-029-0201B	XP2 TST2 sync. cable	215	L-029-0397	Safety extension in / TEX	178
L-029-0204C	Fi motor with encoder	251	L-029-0398	Safety extension out / TEX	179
L-029-0220F	Calibration board	168	L-029-0399	Safety Loop Extension cable	179
L-029-0231B	XXWT X Wagon transducer	209	L-029-0400	Safety Loop Extension end plug	183
L-029-0232	XXME X-motor transducer	221	L-029-0403	XTYBO TEX Y Booster2 cable	181
L-029-0240	MY 134A MOT2 boot PROM	182	L-029-0404	C-motor C-60 with CMB2-board	5
L-029-0243-3	Accuracy test board 1 ed. 3	166	L-029-0409	XZFG Z-Fi ground cable	254
L-029-0250	Fuse kit	163	L-029-0416	Power Relay with cables / TEX	182
L-029-0260	D9FTE DSUB-9 F mod. 6/6 straight	182	L-029-0417	Jumper / TEX	182
L-029-0267-1	Computer Box 1	32	L-029-0422-1	XNET voltage 345/200V	158
L-029-0272-3	MOT2 board for tray elevator	186	L-029-0423-1	XNET voltage 250/145V	158
L-029-0275	Emergency relay connector	236	L-029-0424-1	XNET voltage 240/140V	158
L-029-0276-3B	XWB3 X Wagon board 3	207	L-029-0425-1	XNET voltage 235/136V	158
L-029-0282-1	XNET voltage 435/250V	158	L-029-0426-1	XNET voltage 230/133V	158
L-029-0283-3	XNET voltage 415/240V	158	L-029-0427-1	XNET voltage 225/130V	158
L-029-0284-3	XNET voltage 400/230V	158	L-029-0428-1	XNET voltage 215/125V	158
L-029-0285-1	XNET voltage 390/225V	158	L-029-0429	DC/DC converter 25V cabled	20
L-029-0286-1	XNET voltage 380/220V	158	L-029-0488G	MY104g PAL WMF30	96
L-029-0287-1	XNET voltage 370/215V	158	L-029-0489I	MY104i PAL TM8	96
L-029-0288-3	XNET voltage 210/121V	158	L-029-0490I	MY104i PAL TM1216	96

## Part Number Index

Part no.	Product name	Page	Part no.	Product name	Page
L-029-04911	MY104i PAL TM24	96	L-045-0511	Belt tension wheel	54
L-029-04921	MY104i PAL TM12	96	L-045-0550	Spare screw kit T3/T4	44
L-029-04931	MY104i PAL TM16	96	L-045-0551	T4 Gable top	46
L-029-04941	MY104i PAL TM32	96	L-045-0552	T3 Gable top kit	46
L-029-04951	MY104i PAL TM44	96	L-045-0553	T4 transport belt kit	46
L-029-04961	MY104i PAL TM5632	96	L-045-0555	T4 drive belt kit	46
L-029-04971	MY104i PAL TM8F	96	L-045-0556	T3 drive belt kit	46
L-029-05011	MY104i PAL TMFlex	96	L-045-0557	T4 lift edge kit	46
L-029-0533-2	BM4CB edition 2	31	L-045-0558	T3 lift edge kit	46
L-029-0537	Conveyor motor	52	L-045-0560	T3/T4 lift motor 1	53
L-029-0548	Laser bar code reader	188	L-045-0561	T3/T4 lift motor 2	53
L-029-0555	FFX Spare part kit	150	L-045-0562	T3/T4 transport motor	53
L-040-0034	Spare Part Set 1 MY-Series	176	L-045-0563	T3/T4 width motor	53
L-040-0089	MOD cable & DSUB 9 adapters	23	L-045-0564	T3/T4 hood safety switch	55
L-040-0152	Spare part kit 1 MY with Midas	176	L-045-0649	Torsion spring kit	47
L-040-0153	Spare Part Set 2 MY with Midas	176	L-045-0650	T3 cylindrical pin guide kit	45
L-040-0418	Base spare part set MY generation I7	176	L-045-0651	Guide bushing kit	43
L-040-0556	Machine manual, MY-series	56	L-049-0001-2	MIBB Magazine Interface Bus Board	112
L-040-1076	DVC Sparepart	204	L-049-0008	MOT3 board with ejector	28
L-040-1078	Printer OKI B4350nPS	153	L-049-0012	XBOF M-Booster flat cable	159
L-040-1082	LCD monitor balance kit	119	L-049-0016	XMF1 glue cable 1	118
L-040-1084	LVS calibration component kit	201	L-049-0033	XXW1-2 50 pole cable	216
L-041-0084	Fan connection board	121	L-049-0034	XXW2A+B - 2 X wagon cable	218
L-041-0141	Key top F10 spare part kit	22	L-049-0035	XXW1-2 X Wagon cable	216
L-041-0410	Bracket vertically adjustable	119	L-049-0036	XXW2A+B X Wagon cable	219
L-043-0003	Cable wagon complete with rollers MY19	211	L-049-0039	Keyboard cable extender	14
L-043-0012	Belt tension roller	235	L-049-0062	XMIF2 cable	100
L-043-0025	Cable wagon complete with rollers MY15	211	L-049-0064-4	Mains input unit	164
L-043-0043	Cable wagon complete with rollers MY12	211	L-049-0085B	Trackball with emergency button	12
L-043-0044	Cable wagon complete with rollers MY9	211	L-049-0088	BM3CB with R6 for MY-series	12
L-043-0066	Drive shaft repair kit	223	L-049-0091	X Wagon motor connector	231
L-043-0067	X-belt motor kit	231	L-049-0102B	Fuse kit MY-Series	162
L-043-0104	X-wagon encoder kit	224	L-049-0111-3	EPT2 edition 3, Elmo Power Transformer	164
L-045-0413	YM fan kit	48	L-049-0113	Safety loop extension cable	16
L-045-0414	Spare screw kit T5/T6	45	L-049-0117	CRT Monitor	33
L-045-0415	Spare screw kit small	44	L-049-0118	X Wagon motor complete	209
L-045-0417	YM crash protection kit	241	L-049-0120B	XXME X-motor transducer	222
L-045-0418	YM cable chain	241	L-049-0123	XPOW1 Cable	20
L-045-0420	Safety switch rear hood	43	L-049-0125	XDD1 Cable	17
L-045-0421	YM linear encoder	241	L-049-0141	MI-MOT3 unit with ejector	33
L-045-0422	YM linear scale replacement kit	241	L-049-0162	MOT3 with front panel	29
L-045-0423	Safety switch front hood	43	L-049-0166	XXW1-2 X Wagon cable	216
L-045-0424	YM amplifier	240	L-049-0167	XXW2A+B X Wagon cable	219
L-045-0425	YM control board	47	L-049-0168	XXW1-2 X Wagon cable	217
L-045-0426	T5 gable top kit	47	L-049-0169	XXW2A+B X Wagon cable	219
L-045-0427	YM grease	241	L-049-0175	VGA-VGA Adaptor Cable for VVG2	16
L-045-0428	YM linear scale cleaning kit	241	L-049-0184	Computer Box 2	32
L-045-0429	T6 drive belt kit	47	L-049-0185	MI-MOT3 with front panel	28
L-045-0430	T6 transport belt	38	L-049-0202	LED Cable	200
L-045-0431	T5 drive belt kit	46	L-049-0218-3B	OCLDH edition 3B	205
L-045-0433	T6 Lift edge kit	47	L-049-0232	XMIB4 cable	98
L-045-0434	Board sensor	43	L-049-0241	BOX 12V 5V	32
L-045-0435	T5/T6 motor	53	L-049-0248	MOT3D with front panel	232
L-045-0436	T5 transport belt	38	L-049-0252	Safety switch YWU hood	240
L-045-0437	Control board	43	L-049-0253	Control Unit with cables	245
L-045-0439	T5 Lift edge kit	47	L-049-0254	Computer box 2 with BM4	32
L-045-0440	T6 gable top kit	47	L-049-0272	UPS-Sever cable	159
L-045-0441	Slide part support kit	44	L-049-0424B	XHYD HYDB-XWB3 cable	124
L-045-0501	Lift table T4	54	L-049-0428	WSR-XVS cable kit	213
L-045-0509	Lift table T3 sheetmetal	54	L-049-0441	Safety switch ELF3 flat key with cables	121
			L-049-0473	UPS-Server cable	159
			L-049-0508	Board jam sensor with connector	42
			L-049-0512	NTC with cable	125

## Part Number Index

Part no.	Product name	Page	Part no.	Product name	Page
L-049-0535-3B	OCLDM edition 3B	205	P-020-0027-EN	TPSys 2.5 machine manual	57
L-049-0565	MCU spare part kit	105	P-020-0028-EN	TPSys 2.5 Software manual	58
L-049-0591	PS4 - power supply	164	P-040-0055-DA	Maintenance guide - Danish	56
L-049-0604	Box 12V 5V /120VAC	163	P-040-0055-DE	Maintenance guide - German	56
L-049-0608	UPS spare part with box 12V/5V	163	P-040-0055-EN	Maintenance guide - English	56
L-049-0635	TST2 spare part	234	P-040-0055-ES	Maintenance guide - Spanish	56
L-049-0661	UPS EBK-350 with plastic feet	165	P-040-0055-FI	Maintenance guide - Finnish	56
L-049-0677	UPS Powerware 3110 upgrade kit	162	P-040-0055-FR	Maintenance guide - French	56
L-049-0678	UPS replacement	163	P-040-0055-IT	Maintenance guide - Italian	56
L-049-0685	ZFIB spare part kit	149	P-040-0055-JA	Maintenance guide - Japanese	56
L-049-0686	UPS spare part with box 12V/5V	163	P-040-0055-NL	Maintenance guide - Dutch	56
L-049-0687	UPS spare part for Powerware 3110 with AT	163	P-040-0055-NO	Maintenance guide - Norwegian	56
L-049-0697	LSC FL power supply spare part	205	P-040-0055-PT	Maintenance guide - Portuguese	56
L-049-0698	X-wagon motor MY refurbished	232	P-040-0055-SV	Maintenance guide - Swedish	56
M-0001	Lock ring LRA	111	SH74HC244	74HC244	219
M-0943	O-ring 3.0x1.0	251	SH74LS244	74LS244	100
M-0944	O-ring 3.1x1.6	123	SHL603	8x400 mA 90V Darlington driver	220
M-1164	Hexagonal key 263, 0.9x40	169	SHL603	8x400 mA 90V Darlington driver	220
M-1553	O-ring 4.6x2.4	157	SHULN2065B	ULN2065B darlington driver	22
P-010-0152-EN	MYPlan 3.0 User's Manual	56	SHX24C02	X24C02P DIL-8	183
P-010-0779-EN	TPSys 2.3 Software manual	57	SSTRANZ24V600	Tranzorb 24V 600W	21
P-010-0814-EN	TPSys 2.4 Software manual	57	U-014-0037	Push soleniod, 8-pack	69
P-020-0014-EN	TPSys 2.3 Operator's manual	57	U-015-0001	Lead screw with nut	242
P-020-0015-EN	TPSys 2.3 Programming manual	57	U-015-0002	Lead screw with nut	242
P-020-0016-MB	Safety Manual, MY Series & TP Series,	57	U-015-0005	Steel axle with ball bushing	243
P-020-0023-DE	TPSys 2.4 Operator's manual - German	56	U-015-0006-3	Steel axle with ball bushing	243
P-020-0023-EN	TPSys 2.4 Operator's manual - English	56	U-015-0008	Y Wagon motor	244
P-020-0023-FI	TPSys 2.4 Operator's manual - Finnish	56	U-015-0014	Grease Tube NSK No. 1	244
P-020-0023-FR	TPSys 2.4 Operator's manual - French	56	U-023-0001	Tygaflor tape 24mm	231
P-020-0023-IT	TPSys 2.4 Operator's manual - Italian	56	U-025-0001-4	Board transport belt	37
P-020-0023-JA	TPSys 2.4 Operator's Manual - Japanese	56	U-029-0015	ELMO servo amplifier	236
P-020-0023-NL	TPSys 2.4 Operator's manual - Dutch	56			
P-020-0023-PT	TPSys 2.4 Operator's manual - Portuguese	56			
P-020-0024-DE	TPSys 2.4 Programming manual - German	56			
P-020-0024-EN	TPSys 2.4 Programming manual - English	56			
P-020-0024-FI	TPSys 2.4 Programming manual - Finnish	56			
P-020-0024-FR	TPSys 2.4 Programming manual - French	56			
P-020-0024-IT	TPSys 2.4 Programming manual - Italian	56			
P-020-0024-JA	TPSys 2.4 Programming manual - Japanese	56			
P-020-0025-DE	TPSys 2.5 Operator's manual - German	56			
P-020-0025-EN	TPSys 2.5 Operator's manual - English	56			
P-020-0025-ES	TPSys 2.5 Operator's manual - Spanish	56			
P-020-0025-FI	TPSys 2.5 Operator's manual - Finnish	56			
P-020-0025-FR	TPSys 2.5 Operator's manual - French	56			
P-020-0025-IT	TPSys 2.5 Operator's manual - Italian	56			
P-020-0026-EN	TPSys 2.5 Programming manual	57			

## Replaced Articles

Replaced	New Article No.	Page	Replaced	New Article No.	Page
D-012-0114B-4	D-012-0717-4	249	L-012-0353	L-012-0364	126
D-012-0222-3	D-012-0718-3	249	L-012-0381	L-012-0381B	156
D-012-0248C-4	D-012-0248D	155	L-012-0422	L-012-0131	170
D-012-0255C-4	D-012-0255D	156	L-012-0435B	L-012-0809	128
D-012-0276-4 D-012-0278-4	L-012-0133	7	L-012-0440	L-012-0440B	128
D-012-0308B-4	D-012-0308C	155	L-012-0442	L-012-0609	130
D-012-0404B-4	D-012-0404C	156	L-012-0509	L-012-0509B	127
D-012-0408-4	D-012-0408B	154	L-012-0808	L-012-0853	128
D-014-0026-4	D-014-0026B-4	110	L-014-0090	L-014-0090C	69
D-014-0435D-4	L-014-0518	78	L-014-0095	L-014-0095C	77
D-022-0027-4 D-022-0028B-3	L-022-0008	5	L-014-0106B	L-014-0106C	87
E-011-0025	E-011-0026	116	L-014-0107B	L-014-0107C	87
E-011-0025	E-011-0026	116	L-014-0148	L-014-0910	85
E-011-0030	E-011-0049	117	L-014-0253	D-014-0860-3	82
E-013-0008	E-013-0017	161	L-014-0275	L-014-0275D	113
K-012-0005	L-012-0370	193	L-014-0428	L-014-0911	97
K-012-0045	K-012-0015	196	L-014-0443	L-014-0443D	62
K-012-0045	K-012-0024	197	L-014-1334	L-014-1334B	103
K-012-0045	K-012-0016	198	L-014-1364	L-014-1364B	101
K-012-0081	K-012-0108	128	L-015-0326B	L-015-0326C	244
K-012-0085	L-012-0122	255	L-015-0335	L-015-0431B	129
K-012-0122	K-012-0122B	127	L-019-0004	L-019-0004B	255
K-013-0007	K-013-0035	230	L-019-0004	L-019-0004B	255
K-013-0016	K-013-0036	226	L-019-0007B	L-019-0007C	255
K-013-0027	K-043-0007	120	L-019-0008	L-029-0537	52
K-014-0002	K-012-0002	253	L-019-0009-6	L-019-0009-8	164
K-014-0002	K-012-0002	253	L-019-0011-5	L-019-0011-6	164
K-014-0002	K-012-0002	253	L-019-0012	L-019-0012B	244
K-014-0009	K-014-0037-R	69	L-019-0012	L-019-0012B	244
K-014-0012	K-014-0012B	101	L-019-0021-1C	L-019-0021-1D	74
K-014-0037-R	U-014-0037	69	L-019-0022-1	L-019-0022-3	164
K-015-0008	L-012-0852	230	L-019-0029-2H	L-019-0029	28
K-019-0003	K-019-0003B	29	L-019-0037-3C	L-019-0037-3D	207
K-019-0019	K-019-0384	11	L-019-0039-2	L-019-0039-4B	113
K-019-0157	L-019-1017	27	L-019-0041-2C	L-019-1113	235
K-019-0161	K-019-0161B	21	L-019-0049-5A	L-019-0049	28
K-019-0168	K-019-0018	21	L-019-0059	L-019-0059C	27
K-019-0210	K-019-0210B	29	L-019-0063-4B	L-019-0063-5C	234
K-019-0214	K-019-0389	34	L-019-0075B	L-019-0075E	222
K-019-0305	K-019-0360	195	L-019-0078	L-019-0078B	217
K-019-0343B	K-019-0343C	23	L-019-0079	L-019-0079B	218
K-019-0357	L-019-1058	25	L-019-0083B	L-019-0083C	120
K-019-0358	L-019-1059	25	L-019-0091	L-019-0424	20
K-019-0369	L-019-1106	158	L-019-0095	L-019-0095B	98
K-022-0038	L-022-0136	149	L-019-0100	L-019-0100B	254
K-022-0045	L-022-0120	150	L-019-0106	L-019-0106B	73
K-023-0004B	L-043-0067	231	L-019-0169I	L-029-0488G	96
K-023-0019	U-023-0001	231	L-019-0169I	L-029-0492I	96
K-024-0017	L-024-0182	240	L-019-0169I	L-029-0490I	96
K-024-0017	L-024-0182	240	L-019-0169I	L-029-0493I	96
K-031-0005	K-031-0005B	24	L-019-0169I	L-029-0491I	96
K-043-0007	K-043-0010	230	L-019-0169I	L-029-0494I	96
K-043-004B	K-043-0004B	226	L-019-0169I	L-029-0495I	96
K-049-0077A K-049-0078A	L-049-0117	33	L-019-0169I	L-029-0496I	96
K-049-0150	L-049-0608	163	L-019-0169I	L-029-0489I	96
K-049-0171	L-049-0678	163	L-019-0169I	L-029-0497I	96
L-010-0346	L-010-0347B	22	L-019-0169I	L-029-0501I	96
L-010-0810C	L-010-0810D	172	L-019-0179 + L-019-0179B	L-019-0179C	21
L-010-0830	L-010-0849	172	L-019-0225-5B	L-019-0225-6	54
L-011-0040	L-040-1076	204	L-019-0237	L-019-0237B	238
L-012-0073	L-012-0073B	253	L-019-0295	L-019-0295B	244
L-012-0128	L-012-0713	124	L-019-0303-1	L-019-0303B	201
L-012-0129	L-012-0711	124	L-019-0307B	L-029-0153	215
L-012-0129	L-012-0712	124	L-019-0322-2	L-019-0322-3	235
L-012-0351	L-012-0436	130	L-019-0470	L-019-0470B	19

## Replaced Articles

Replaced	New Article No.	Page	Replaced	New Article No.	Page
L-019-0499	L-019-0499B	19	L-049-0111-2	L-049-0111-3	164
L-019-0527	L-019-0527B	98	L-049-0120	L-049-0120B	222
L-019-0619	L-019-0619B	222	L-049-0193	L-049-0697	205
L-019-0624-2	L-019-0624-3	235	L-049-0213-3B	L-049-0218-3B	205
L-019-0633-2	L-019-0107	169	L-049-0268	L-029-0533-2	31
L-019-0657-2B	L-019-0657-2C	25	M-0946	M-1553	157
L-019-0660-1	L-019-0660-1B	25	U-024-0001-4 + U-024-0002-4	L-024-0178	178
L-019-0672B	L-049-0424B	124	U-024-0002-4	L-024-0179	178
L-019-0719-2	L-019-0719-3	26	VE9910005	L-029-0429	20
L-019-0759	L-019-0759B	222			
L-019-0803-3B	L-019-0803-3C	26			
L-019-0804-2	L-019-0811-2	205			
L-019-0837-1B	L-019-0837-2B	203			
L-019-0991	L-019-0827-2C	30			
L-019-0998B	L-019-1083	30			
L-019-1028	L-019-1084	30			
L-019-1029	L-019-1087	31			
L-019-1086	L-019-1098	31			
L-019-1089B	L-019-1089C	22			
L-022-0002B	L-022-0002C	3			
L-022-0004	L-022-0073	250			
L-022-0065	L-022-0065B	247			
L-022-0065	L-022-0065B	247			
L-022-0105	L-022-0105B	147			
L-029-0003	L-029-0003-1B	121			
L-029-0036-3	L-029-0036-5B	234			
L-029-0037-3-M	L-049-0635	234			
L-029-0080	L-049-0008	28			
L-029-0157	L-029-0157B	250			
L-029-0169	L-029-0404	5			
L-029-0191	L-029-0191B	253			
L-029-0191	L-029-0191B	253			
L-029-0199	L-029-0199B	250			
L-029-0204B	L-029-0204C	251			
L-029-0231	L-029-0231B	209			
L-029-0243-2	L-029-0243-3	166			
L-029-0276-2B	L-029-0276-3B	207			
L-029-0283-1	L-029-0283-3	158			
L-029-0284-2	L-029-0284-3	158			
L-029-0288-2	L-029-0288-3	158			
L-029-0289-2	L-029-0289-3	158			
L-029-0295	L-029-0295-3	161			
L-029-0296	L-029-0296-3	161			
L-029-0301-1	L-029-0301B	32			
L-029-0304	L-049-0162	29			
L-029-0310-1B	L-029-0310-3B	233			
L-029-0320-2D	L-029-0320-3	233			
L-029-0323-3	L-029-0323-3B	187			
L-029-0358-1	L-029-0358-2	158			
L-029-0359-1	L-029-0359-2	158			
L-029-0360-2	L-029-0360-3	158			
L-029-0361-1	L-029-0361-2	158			
L-029-0366-2	L-029-0555	150			
L-029-0367-2	L-029-0367-3	234			
L-029-0383	L-029-0383B	180			
L-029-0506	L-019-0108	169			
L-029-0507	L-019-0106B	73			
L-029-0507	L-019-0106B	73			
L-040-0031	L-040-0034	176			
L-040-0233	L-040-0556	56			
L-043-0020	L-043-0066	223			
L-049-0014B	L-043-0104	224			
L-049-0064-3	L-049-0064-4	164			
L-049-0085	L-049-0085B	12			
L-049-0102	L-049-0102B	162			



## Alphabetical Index

Product name	Part no.	Page	Product name	Part no.	Page
24V DC motor + gear	L-019-0106B	73	ATI3 AT interconnect board 3	L-019-0660-1B	25
24V DC motor + gear	L-019-0106B	73	Axle C-60 centering device	D-022-0013B-3	6
24V DC motor + gear	L-019-0106B	73	Axle reel holder	D-014-1077-4	106
3PT1, test circuit board	L-019-0037-3D	207	Axle spindle uncover wheel arm	D-014-0961-4	106
74HC244	SH74HC244	219	Base spare part set MY generation I7	L-040-0418	176
74LS244	SH74LS244	100	BATTERY 12V 7AH, UPS 151X65X94	E-053-0002	160
8x400 mA 90V Darlington driver	SHL603	220	Battery Hitachi 10 Ah 6 V	E-053-0001	160
8x400 mA 90V Darlington driver	SHL603	220	Bearing housing, TEX Shuttle	L-024-0103	187
Accuracy test board 1 ed. 3	L-029-0243-3	166	Bearing housing Y Wagon	K-015-0028-R	242
Adjustable foot	K-017-0074	138	Bearing housing Y Wagon	K-015-0028-R	242
Adjustment tool, smaller	D-007-0019-3	169	Belt AT3/150 W=3	K-014-0065	97
Adjustment tool steering wheel	D-007-0018-3	169	Belt pulley	D-015-0248-4	41
Agilis control board - QMC	L-014-1364B	101	Belt pulley	D-015-0239-3	41
Agilis Drive Unit Frame	L-014-1338	102	Belt pulley	D-015-0240-3	41
Agilis Drive Unit mount	L-014-1328	102	Belt pulley	D-014-0097-4	71
Agilis Eccentric Shaft	L-014-1335	102	Belt pulley Fi-motor	D-012-0718-3	249
Agilis Feeder Wheel Set	L-014-1341	102	Belt pulley T2.5/24 B=10	D-014-0615-4	73
Agilis Feeder Wheel Unit	L-014-1331	102	Belt pulley TWM	L-025-0002	188
Agilis interconnection board kit - QM16FIB	L-014-1551	102	Belt pulley Z-Fi axle	D-012-0717-4	249
Agilis interconnection board kit - QMFIB	L-014-1334B	103	Belt T10/1700 B=10	K-025-0007	178
Agilis Interface Parts	L-014-1327	103	Belt T2.5/120 B=6	K-012-0002	253
Agilis Locking Unit	L-014-1332	103	Belt T2.5/120 B=6	K-012-0002	253
Agilis Motor Unit	L-014-1329	103	Belt T2.5/120 B=6	K-012-0002	253
Agilis Rear Handle Unit	L-014-1330	103	Belt T2.5/145 B=3	K-014-0022	73
Agilis Safety Clamp	L-014-1337	103	Belt T2.5/145 B=6	K-015-0032	36
Agilis Solenoid Unit	L-014-1333	104	Belt T2.5/177.5 B=5	K-022-0007	250
Agilis Waste Shelf	L-014-1339	104	Belt T2.5/200 B=6	K-025-0014	36
Agilis Y-adjustment Unit	L-014-1336	104	Belt T2.5/285 B=6	K-015-0002	238
Air spring, hood	K-011-0027	111	Belt T2.5/317.5 B=4	K-014-0024	71
Air spring, hood	K-011-0028	224	Belt T2.5/380 B=20	K-013-0003	212
Amplifier for slot sensor	K-017-0068	135	Belt T2.5/540 B=6	K-025-0016	37
Antistatic roller, cable wagon	L-013-0019	224	Belt T2.5/650 B=6	K-015-0037	37
Area calibration background 254*456	L-015-1681	166	Belt T2.5/950 B=18	K-015-0004	238
Area calibration background 384*508	L-015-1682	166	Belt T5/1100 B=6	K-015-0038	37
Area calibration background 400*590	L-015-1683	166	Belt T5/920 B=6	K-025-0015	37
Area calibration background 427*461	L-015-1684	166	Belt T5/finite B=20 cord 0.48	K-015-0023	238
Area calibration background 440*508	L-015-1685	167	Belt tension roller	L-043-0012	235
Area calibration background 563*508	L-015-1686	167	Belt tension roller	L-023-0004B	235
Area calibration background 736*609	L-015-1687	167	Belt tension wheel	L-045-0511	54
Area calibration background 914*609	L-015-1688	167	Belt Transport/Buffer	K-017-0163	132
Area calibration background 927*732	L-015-1689	167	BJS calibration plate with label	L-015-0452	167
Area calibration plate	L-012-0634	167	BM3CB with R6 for MY-series	L-049-0088	12
Assembly-jig O-rings	D-012-0158B-4	170	BM3CB with R6 for TP9-4/11	L-019-0692	12
Assembly sheave	K-022-0022	225	BM3CB with R6 for TP9-4/11 HYDRA	L-019-1001	12
Assembly tool for Z-mid. axle	D-007-0016-3	170	BM3CB with R6 TP9-2U	L-019-0753	12
ATC2 AT connector board 2	L-019-0657-2C	25	BM4CB edition 2	L-029-0533-2	31
ATC AT connector board	L-019-0317-1B	25	BNB edition 3	L-019-0624-3	235
AT-CPU2 PF2 with CP54 boxed	L-019-1151	31	Board guide rail	L-019-0730	23
AT-CPU2 PF2 with CP5 boxed	L-019-1152	31	Board jam sensor with connector	L-049-0508	42
AT-CPU2 with CP5	L-019-1098	31	Board lock, left	L-025-0010	48
AT-CPU2 with CP54 for Linux	L-019-1087	31	Board lock, right	L-025-0011	48
AT-CPU PF2 with CP54 boxed	L-019-1150	30	Board lock arm Conveyor	D-025-0211B-3	48
AT-CPU with CP4	L-019-1083	30	Board sensor	L-045-0434	43
AT-CPU with CP54 for Linux	L-019-1084	30	Board transport belt	U-025-0001-4	37
			Board transport belt T2.5/1300 B=4	K-015-0011-R	38
			Booster 2 edition 3	L-019-0322-3	235
			Booster BNB/NREG complete	L-019-0902	235
			Booster spare part kit	L-019-1113	235
			Bottom plate, magazine feeder unit complete	L-014-0122	65
			BOX 12V 5V	L-049-0241	32
			Box 12V 5V /120VAC	L-049-0604	163
			Bracket	D-015-1851	48
			Bracket, module Flex feeder	D-014-0769-4	107

## Alphabetical Index

Product name	Part no.	Page	Product name	Part no.	Page
Bracket for Sunx sensor	D-025-0523	36	Configured MAT915	L-019-1146	25
Bracket vertically adjustable	L-041-0410	119	Contact cover WSR2	L-019-0667	236
Brake-disc for feeder wheel	D-014-0617-3	81	Container for tape reels TM1216C	L-014-0177	61
Brushes, Set of 4	K-022-0042	149	Container for tape reels TM12C	L-014-0175	61
C60 steel belt repair kit	L-022-0008	5	Container for tape reels TM16C	L-014-0176	61
Cable wagon complete TP11	L-013-0120	211	Container for tape reels TM24D	L-014-0178	61
Cable wagon complete TP12	L-023-0033	211	Container for tape reels TM32D	L-014-0289	61
Cable wagon complete TP18	L-023-0030	211	Container for tape reels TM44D	L-014-0492	62
Cable wagon complete TP9-1/2	L-013-0015	211	Container for tape reels TM5632D	L-014-0505	62
Cable wagon complete TP9-3	L-013-0115	211	Container for tape reels TM8C	L-014-0112	62
Cable wagon complete TP9-4	L-013-0127	211	Container for tape reels TM8FC	L-014-0449	62
Cable wagon complete with rollers MY12	L-043-0043	211	Container for tape reels TMD Flex	L-014-0443D	62
Cable wagon complete with rollers MY15	L-043-0025	211	Control board	L-045-0437	43
Cable wagon complete with rollers MY19	L-043-0003	211	Control Unit with cables	L-049-0253	245
Cable wagon complete with rollers MY9	L-043-0044	211	Conveyor bracket model 1	L-025-0070	49
Cable wagon upgrade	L-023-0110	223	Conveyor bracket model 2	L-025-0075	49
Calibration board	L-029-0220F	168	Conveyor bracket TP12/18	L-025-0071	49
Calibration components	L-012-0633	168	Conveyor dummy din connector	L-019-0403	42
Calibration plate	D-019-0377D-4	166	Conveyor motor	L-029-0537	52
Calibration plate	L-010-0452B	168	Conveyor safety adapter cable	L-019-0426	38
Calibration plate	L-019-0329	168	Conveyor safety cable (double)	L-019-0427	38
Calibration plate	L-019-0447	168	Conveyor safety sensor	L-019-0428B	39
Cam follower	K-017-0166	139	Conveyor safety sensor	L-019-0440	42
Carbon Brush for F12 M4	K-029-0035	228	Conveyor safety sensor	L-019-0845	54
Card edge holder	D-025-0062-2	48	Cordset IEC-US 7m	K-019-0372	158
Card edge holder	D-025-0195B-2	49	Cover glue station	D-014-0723B-4	123
Card edge holder, conveyor	D-015-0256-2	49	Cover plate complete	L-014-0125	95
Cassette holder, lower	K-017-0065	132	Cover tape ruler, long	D-014-1826	107
Cassette holder, upper	K-017-0066	132	Cover tape ruler, short	D-014-1827	107
Cassette transport belt	K-017-0058	132	Cover tube	D-014-0915-4	107
Cassette transport belt, lower	K-017-0056	132	CP4 without front panel	L-019-1005-2A	26
Cassette transport belt, upper	K-017-0057	133	CP4 without front panel	L-019-0241-2A	26
CD-ROM kit SCSI	L-010-0347B	22	CP54 edition 1C	L-019-1020-1C	26
Centering axle bearing	L-012-0058	7	CP5 central processor board 5	L-019-0803-3C	26
Centering electrodes for C60	L-029-0175B	5	CPP CP5-ISA plug-in board edition 3	L-019-0719-3	26
Centering electrodes upgrade	L-019-0081D	7	CRT Monitor	L-049-0117	33
Centering electrodes w/o cable	L-019-0476-5B	8	Cylinder in pusher	K-017-0224	140
Centering steel belt repair kit	L-012-0133	7	D25F DSUB-25 F mod. 6/6 straight	L-019-0513B	12
Centering unit C60 complete	L-022-0002C	3	D25FX DSUB-25 F mod. 6/6 cross	L-019-0514B	12
Centering unit complete	L-012-0006C	9	D9F DSUB-9 F mod. 6/6 straight	L-019-0511B	12
Centering unit cover, bottom	D-012-0428-3	7	D9FTE DSUB-9 F mod. 6/6 straight	L-029-0260	182
CMB2 Ed-1E	L-029-0371-1E	5	D9FX DSUB-9 F mod. 6/6 cross	L-019-0512B	12
C-motor C-60 with CMB2-board	L-029-0404	5	D9M DSUB9M MODULAR 6/6	L-019-0497B	12
C-motor with console	L-012-0055	8	Damper	K-015-0090	243
Cogbelt TEX Shuttle Unit	K-024-0026	178	DC/DC converter 25V cabled	L-029-0429	20
Cog wheel	D-022-0049-4	249	DC/DC converter without cables	E-991-0005	20
Cog wheel, TEX Mother Unit	D-024-0148-3	182	DC-motor 12V 40 rpm	K-017-0054	141
Cogwheel 15 teeth, plastic	D-014-0708-4	122	DC motor 12V 80RPM	K-017-0109	142
Cogwheel 18 teeth	D-012-0049-4	254	DC motor 12V 80rpm for BC	K-017-0064	142
Cogwheel 50 teeth, plastic	D-014-0707-4	123	DC-motor 24V	K-017-0052	141
Component reject bin	K-041-0017	119	DC motor 24V 130RPM	K-017-0108	142
Component reject bin	K-011-0010	225	DC motor 24V 40RPM	K-017-0110	142
Component separator spring TM8C	L-014-0910	85	DC motor 24V 80RPM	K-017-0111	142
Component separator spring TM8FC	L-014-0445	85	DC-motor 24V elevator	K-017-0055	141
Computer Box 1	L-029-0267-1	32	DCRB regulator board	L-029-0087-2B	186
Computer Box 1	L-019-0001-4	32	Diffusor pyramid optical cent.	D-021-0223-4	201
Computer Box 2	L-049-0184	32	Digitizer cable	L-019-0214	13
Computer Box 2	L-029-0301B	32	Digitizer cable Océ Graphics	L-019-0214B	13
Computer box 2 with BM4	L-049-0254	32	Disc Drive 3.5" Sony	K-019-0343C	23
Configured CPU-card without VGA	L-019-1058	25	Disc Oldham coupling	K-019-0360	195
Configured CPU-card with VGA	L-019-1059	25	Disc Oldham coupling	K-019-0022	195
			Disk drive 3.5" mount kit	L-019-0704	22
			Disk drive for TP9	K-019-0113	23
			Diskette 25/2D 5.25"	K-010-0016	24

## Alphabetical Index

Product name	Part no.	Page	Product name	Part no.	Page
Door switch with cable	L-029-0189	178	Feeder wheel TM56D	L-014-0892	101
Drive axle complete	L-014-0105	87	Feeder wheel TM8FC	D-014-0851-2	81
Drive axle with bearings	L-013-0139	223	FFX Spare part kit	L-029-0555	150
Drive belt Conveyor/Destacker	K-017-0275	133	FGB frame grabber board	L-019-0277-3B	27
Drive shaft repair kit	L-043-0066	223	Filter cloth	K-021-0025	120
Drive shaft with bearings	L-023-0003	224	Filter fan ZFF250/115VAC	K-011-0052B	120
Drive unit	L-014-1548	104	Filter ZFF 250	K-011-0051	120
Drive wheel C-60	D-022-0121-3	6	Fi motor with encoder	L-029-0204C	251
Drum for OKI B4300/B4350	K-040-0195	152	Fi motor with encoder	L-019-0007C	255
Drum OKI 14i	K-040-0132	153	Flexible joint (3x4) TE	K-022-0024	184
DVC Sparepart	L-040-1076	204	Flexible joint 14/19	K-013-0025	225
DVD-rom drive SCSI	K-031-0005B	24	Flexible joint 14/19	K-013-0025	225
EBM	L-019-0381-1	186	Flexible joint 19x24	K-023-0001	226
Eccentric bushing, left	L-014-0229	88	Flexible joint 3/4	K-024-0012	108
Eccentric bushing, right	L-014-0230	87	Flexible joint 6/10	K-023-0005	226
ELMO Motherboard 1	K-029-0017	220	Flexible joint 6x6	K-022-0023	229
ELMO Motherboard 2	K-029-0018	220	Flexible joint 8/10	K-015-0029	242
Elmo power supply board	K-029-0016	220	Flexible joint 8/8	K-024-0015	183
Elmo safety relay	L-029-0344-1	160	Flexible joint DKN 15/26	K-013-0036	226
ELMO servo amplifier	U-029-0015	236	Flexible joint DKN20/30 spec	K-043-0004B	226
ELMO Servo amplifier	K-029-0015	220	Flexible joint DKN 4/21	K-042-0018	229
Emergency relay connector	L-019-0593	163	Flexible joint X-motor	K-013-0021	226
Emergency relay connector	L-029-0275	236	Flywheel TWM	L-025-0036	188
Encoder	L-014-1566	113	FMB Fi motor board	L-029-0051-1	250
Endpoint switch for elevator	K-017-0069	135	Frame grabber board	K-019-0166	27
End-point switch Y-wagon with cable	L-019-0237B	238	Frame grabber cable	L-019-0436	13
End-position switch, front	L-019-0682	239	Fuse kit	L-019-0128	162
End-position switch rear	L-019-0681	239	Fuse kit	L-019-0487	162
End stop	D-021-0248-4	225	Fuse kit	L-029-0250	163
EPT2 edition 3, Elmo Power Transformer	L-049-0111-3	164	Fuse kit BM3CB	L-019-1003	20
EWB tray elevator board	L-029-0119-2	186	Fuse kit Booster	L-019-1002	221
Expander wheel, conveyor	L-015-0070	50	Fuse kit MY-Series	L-049-0102B	162
Fan, HYDRA	L-019-0668	124	Fuse kit Power Supply	L-019-1000	160
Fan, X Wagon motor	K-022-0002	228	Fuse ultra fast 1/16 A (pico)	E-041-0232	30
Fan 119x119x38 160 m3/h 110V	E-992-0010	119	Fuse ultra-fast 1.5 A (pico)	E-041-0240	30
Fan 120x120 24V 5W	E-992-0005	117	Fuse ultra fast 4 A (pico)	E-041-0245	30
Fan 172x150x38 330 m3/h 110V	E-992-0011	117	FXOS-14MT-DSS PLC,E53-PLC-10	K-017-0180	140
Fan 80x80x32	K-021-0003	117	FXOS-20MT-DSS PLC,E53-PLC-11	K-017-0181	140
Fan axial 80x80x38 230V	E-992-0015	220	Gauge - Line Scan Camera	L-010-0422	202
Fan connection board	L-041-0084	121	GfIB edition 1, Generic Feeder Interface Board	L-019-1109-1	112
Fan ELMO	L-019-0785	221	Glide list	L-025-0042	185
Fastener kit HYDRA 2D	L-012-0614	125	Glue pot with leveling arm	L-014-0701	123
Feeder arm, drive side	L-014-0107C	87	Grease cartridge, cabled	K-012-0055	207
Feeder arm, Fine Pitch	L-014-0300	87	Grease Gun for X-rail	L-015-0395	170
Feeder arm, Fine Pitch	L-014-0299	87	Grease Gun with Filter for YWU	L-015-0397	170
Feeder arm, standard	L-014-0106C	87	Grease paste	K-013-0014	229
Feeder head kit - ALM1216	L-014-1523	104	Grease paste	K-013-0014	229
Feeder head kit - ALM8	L-014-1513	105	Grease paste for X-rail	K-013-0028	229
Feeder head unit - ALM1216	L-014-1546	105	Grease tube 25g	K-012-0122B	127
Feeder head unit - ALM8	L-014-1545	105	Grease Tube NSK No. 1	U-015-0014	244
Feeder motor unit	L-014-0098	73	Grease Tube Retinax EP 2	K-015-0091	229
Feeder number bar TM12C	L-014-0221	65	Grooved nut M6 for Alu-profile	K-017-0079	139
Feeder number bar TM5632D	L-014-0504	107	Grooved nut M8 for Alu-profile	K-017-0080	139
Feeder number bar TM8C	L-014-0128	65	Ground pin for X-belt	D-011-0166-4	227
Feeder solenoid TM 1*	K-014-0008	69	Guide bushing kit	L-045-0651	43
Feeder solenoid TM 8	K-014-0037-R	69	Guide pin	D-011-0048-4	108
Feeder spring console complete	L-014-0275D	113	Guide wheel, fixed, X wagon	K-042-0001	227
Feeder wheel	D-014-0852-2	81	Guide wheel, X Wagon	K-022-0003	227
Feeder wheel	D-014-1813	107	Handle	D-014-0664-4	65
Feeder wheel 12mm	L-014-0251	96	Hard disk	K-019-0197F	24
Feeder wheel 16mm	L-014-0252	96	Hard drive WD800 BB	L-019-1089C	22
Feeder wheel TM32D	L-014-0890	101	Hexagonal key 263, 0.9x40	M-1164	169
Feeder wheel TM44D	L-014-0891	101	Hitachi 5K100 40GB	L-019-1156	22
			HLB HYDRA LED board	L-019-0813-2	203



Product name	Part no.	Page	Product name	Part no.	Page
HLCCL HYDRA LED & Camera cntrl	L-019-0812-3	203	Load position sensor	L-029-0126	178
Hold-down spring complete	L-014-0115	113	Locking screw	L-025-0078	184
Holder for vacuum filter	K-012-0015	196	Lock ring LRA	M-0001	111
Holder spring	D-014-0482-4	108	Lock with key	K-021-0019	120
Hub	D-014-1812	108	Long bracker for SUNX sensor	D-025-0524	36
Hub for TM8 uncover roller	D-014-0507B-4	108	LSAD edition 2B	L-019-0837-2B	203
HYDB2 HYDRA device board 2	L-019-0892-1	129	LSAD-LSPW LED control cable	L-019-0870	200
HYDRA 2B ATE upgrade kit	L-015-1577	125	LSAD-LSS Multi video cable	L-019-0868	200
HYDRA 2D Maintenance kit	L-015-1658	125	LSAD-VVG2 & LSAD-LSAD cable	L-019-0940	200
HYDRA 2D MY Refurbished	L-012-0711	124	LSC FL power supply spare part	L-049-0697	205
HYDRA 2D MY Spare Part	L-012-0713	124	LSLD Ed-2B Linescan LED board	L-019-0838-2B	204
HYDRA 2D TP Refurbished	L-012-0712	124	LSPW-LSS power cable	L-019-0869	200
HYDRA adjustment tool	L-012-0131	170	LVS calibration component kit	L-040-1084	201
HYDRA ATE Maintenance kit	L-015-1576	125	LVS reference background, C60	L-010-0428	202
HYDRA Camera box	L-015-0431B	129	Machine manual, MY-series	L-040-0556	56
HYDRA mylar belt spare part kit	L-012-0388	124	Machine serial number circuit	L-019-0179C	21
HYDRA theta-belt spare part kit	L-012-0291	124	Magazine button and bracket	L-014-0465	93
HYDRA Tool	L-012-0433	126	Magazine container bar	D-014-0675-4	109
HYDRA Tool D=2.6	L-012-0364	126	Magazine guide right/left	D-011-0025-3	109
Hydraulic oil	L-012-0122	255	Magazine ref.point sticker 1*5	D-014-0819-4	111
HYDUBB HYDRA DUB board	L-019-0634-2	129	Magnetic strip	K-025-0018	111
HYDUFB2 HYDRA DUF board 2	L-019-0893-2	129	Magnetic valve 3-1/8	K-017-0060	132
HZ-motor unit	L-012-0853	128	Magnetic valve 5/18	K-017-0061	132
IDE to SCSI Converter	K-049-0009	14	Mains input cable Euro standard	K-019-0337	159
Illumination cover	D-015-0675-3	127	Mains input cable US standard	K-019-0276	159
Inductive encoder / TEX	L-029-0386	182	Mains input unit	L-049-0064-4	164
Ink ribbon Fujitsu DL3700	K-010-0045	152	Main Switch 3-pole	E-011-0049	117
In-line adapter sensor	L-017-0016	136	Maintenance guide - Danish	P-040-0055-DA	56
Inner jaw C-60	L-022-0007	5	Maintenance guide - Dutch	P-040-0055-NL	56
Inspection window	D-011-0034-4	118	Maintenance guide - English	P-040-0055-EN	56
Inspection window, inner TP12	D-021-0072-4	118	Maintenance guide - Finnish	P-040-0055-FI	56
Inspection window, inner TP18	D-021-0073-4	118	Maintenance guide - French	P-040-0055-FR	56
Inspection window, middle TP11	D-011-0039-4	118	Maintenance guide - German	P-040-0055-DE	56
Inspection window, outer	D-021-0074-4	118	Maintenance guide - Italian	P-040-0055-IT	56
Intel Pro/100+ spare part	L-019-0030	27	Maintenance guide - Japanese	P-040-0055-JA	56
Isolator	K-012-0058	191	Maintenance guide - Norwegian	P-040-0055-NO	56
JFKB full keyboard cable	L-019-0096	14	Maintenance guide - Portuguese	P-040-0055-PT	56
JFKB joystick full keyboard	L-019-0055-1	33	Maintenance guide - Spanish	P-040-0055-ES	56
Joystick with cable	L-019-0083C	120	Maintenance guide - Swedish	P-040-0055-SV	56
Jumper / TEX	L-029-0417	182	MCU spare part kit	L-049-0565	105
Kevlar rope 3mm	K-023-0026	230	MDA/VGA cable for BIOS check	L-019-0909	14
Keyboard cable extender	L-049-0039	14	Membrane for pump, 5002, 12VDC	K-012-0009	197
Keyboard extension cable	L-019-0477	14	Membrane pump complete	L-019-0279	191
Keyboard US	K-019-0018	21	Membrane push button	E-011-0019	42
Key top F10 spare part kit	L-041-0141	22	Memory 32MEG EDO 60NS SIMM	K-019-0348	24
Lamp 12V, 20W	E-040-0100	221	MGP card	L-019-1017	27
Lamp 12V, 3W	E-040-0102	211	MIBB Magazine Interface Bus Board	L-049-0001-2	112
LAMP 24, 3W BA15S	E-040-0050	152	Midas, spare part kit	L-022-0110	145
Lamp housing X Wagon camera 2	L-012-0121	236	Middle belt pulley	D-013-0019-4	219
Laser bar code reader	L-029-0548	188	MI magazine interface board	L-019-0049	28
Latch washer set of 10	L-012-0858	125	MI-MOT1 unit	L-019-0059C	27
LCD Monitor	K-040-0215	24	MI-MOT1 unit with front panel	L-019-0750	27
LCD monitor balance kit	L-040-1082	119	MI-MOT3 unit with ejector	L-049-0141	33
Lead screw with nut	U-015-0001	242	MI-MOT3 with front panel	L-049-0185	28
Lead screw with nut	U-015-0002	242	Mini motor HP servomotor (Y)	L-019-0006	244
LED Cable	L-049-0202	200	MI with front panel	L-019-0710	33
Lens Eritec 1.3/8mm	K-011-0018	202	MOD cable & DSUB 9 adapters	L-040-0089	23
Lens for X-camera complete	L-012-0049B	211	Monitor 12" monochrome	K-019-0147	33
LIE5 spacer 0.6mm	K-010-0352	170	Monitor cable adapter	L-019-0479	15
Lift table T3 sheetmetal	L-045-0509	54	Monitor RGB	K-019-0389	34
Lift table T4	L-045-0501	54	MOT1 motor control board 1	L-019-0029	28
Linear encoder codestrip	L-010-0421	202	MOT1 with front panel	L-019-0709	28
Linear encoder head	L-010-0420	204	MOT2 board for tray elevator	L-029-0272-3	186
Linescan Camera box	L-010-0450	204	MOT3 board with ejector	L-049-0008	28
Loading spring	D-014-0659-4	109	MOT3D with front panel	L-049-0248	232

## Alphabetical Index

Product name	Part no.	Page	Product name	Part no.	Page
MOT3 with front panel	L-049-0162	29	PAIB2	L-029-0310-3B	233
Motor	L-014-1571	112	PAIB Power amp. interface board	L-029-0091-2B	233
Motor	K-017-0208	142	Parallel Port to SCSI cable	K-010-0344	15
Motor, TEX Shuttle Unit	L-024-0106	185	PC disk drive 5 1/4"	K-019-0161B	21
Motor, width adjustment	L-015-0061	53	PC - PC 25 pole cable	L-019-0327B	15
Motor (external conveyor)	K-017-0164	143	PC - TP9 25 pole cable	L-019-0326B	15
Motor board-transport conveyor	L-015-0063	52	Photo detector IR	E-040-0030	254
Motor controller, E51-U-5	K-017-0179	140	Photo diode IR	E-040-0031	254
Motor for lead screw Y Wagon	L-019-0012B	244	Photo switch	K-017-0165	136
Motor for lead screw Y Wagon	L-019-0012B	244	Photo switch	K-017-0367	136
Motor M22 width adjustment	K-017-0176	143	Pin guide	D-045-0064	50
Motor membrane pump	L-019-0555	195	Plastic axle	D-014-0849-4	65
Motor TEX Mother Unit	L-024-0121	185	Plate Assistant	D-015-1738	129
Motor with transducer	L-015-0326C	244	Plexiglass cover - 288 front	D-015-0774-2	242
MPS motherboard power supply	L-019-0588-1B	233	Plexiglass cover - 468 front	D-015-0886-2	50
MS motor & sensor board TM	L-019-0021-1D	74	Position guide - male	D-011-0140-4	109
Multi-port serial board	K-019-0189	29	Postscript DIMM	K-040-0196	153
Multi-port serial board cable	K-019-0190	15	Power relay	E-013-0102B	160
MY104g PAL WMF30	L-029-0488G	96	Power Relay with cables / TEX	L-029-0416	182
MY104i PAL TM12	L-029-0492I	96	Power supply	L-019-0009-8	164
MY104i PAL TM1216	L-029-0490I	96	Power supply	L-029-0113-2	186
MY104i PAL TM16	L-029-0493I	96	Power supply 2	L-019-0011-6	164
MY104i PAL TM24	L-029-0491I	96	Power supply 3	L-019-0022-3	164
MY104i PAL TM32	L-029-0494I	96	Power transistor kit	L-019-0010	224
MY104i PAL TM44	L-029-0495I	96	Pressure reducing valve	L-012-0099	198
MY104i PAL TM5632	L-029-0496I	96	Pressure tank	K-012-0028	197
MY104i PAL TM8	L-029-0489I	96	Printer cable	L-019-0131	152
MY104i PAL TM8F	L-029-0497I	96	Printer cable	K-019-0207	152
MY104i PAL TMFlex	L-029-0501I	96	Printer Fujitsu DL3700	K-010-0042	153
MY 105B TE serial number PAL	L-019-0420A	182	Printer OKI B4350nPS	L-040-1078	153
MY 134A MOT2 boot PROM	L-029-0240	182	PS4 - power supply	L-049-0591	164
MYPlan 3.0 User's Manual	P-010-0152-EN	56	PUB motor control 2405A	K-017-0070	136
Network card 3Com 3C905CX-TX-M spare part	L-019-0056	23	PUB motor control 2410A	K-017-0071	136
Network card SMC Lanet16C	K-019-0003B	29	Pump motor with cables	L-019-0713	195
Nipple, straight	K-012-0024	197	Pump unit , green	K-023-0013	227
NREG edition 2B	L-019-0625-2B	236	Pusher Loader	K-017-0062	139
NTC with cable	L-049-0512	125	Pusher Unloader	K-017-0063B	139
Nylon cord	K-015-0039	51	Pusher Unloader	K-017-0063	139
Nylon wheel	L-012-0852	230	Push solenoid, 8-pack	U-014-0037	69
Nylon wheel for X and Y	K-015-0008	230	Rack, TEX Mother Unit	D-024-0160-3	184
OCL2 Optical centering board 2	L-029-0122-2	204	Rack for Z-drive	D-012-0045B-3	254
OCLD edition 2	L-019-0811-2	205	Rack for Z-Fi drive	D-022-0037B-2	249
OCLDH edition 3B	L-049-0218-3B	205	Rail guide, TEX Mother Unit	K-024-0034	184
OCLDM edition 3B	L-049-0535-3B	205	RCYMT TEX RC-unit to Y-motor	L-029-0385	183
OCL optical centering board	L-019-0291-3	204	Rear handle, ALM1216	L-014-1574	113
Oiler, HYDRA	K-012-0109	127	Rear handle, ALM8	L-014-1573	113
Oldham coupling	L-014-1565	112	Rear unit	L-014-1603	113
Omega 28 tube 15g	L-012-0860	157	Reel spring for conveyor	L-015-0222B	54
Optical calibration plate Hydra Camera	L-019-0107	169	Reference magazine	L-007-0005	171
Optical calibration plate kit SVC & HRC	L-019-0108	169	Reference points complete type 14	L-012-0509B	127
Optical centering shadow frame	D-011-0158C-3	202	Reference points complete type 23	L-012-0550	129
OREG edition 2B	L-019-1013-2B	236	Reflector plate	K-017-0073	139
O-ring 3.0x1.0	M-0943	251	Reflex protection Z Wagon	D-012-0898	127
O-ring 3.1x1.6	M-0944	123	Reflex tape	K-024-0009	112
O-ring 4.6x2.4	M-1553	157	Relay	K-017-0168	137
O-ring mounter kit	L-012-0623	171	Relay 220V AC 2VX	E-013-0003	160
O-ring package	L-012-0553B	126	Relay emergency stop 24V	E-013-0017	161
Outer jaw C-60	L-022-0006	6	Relay emergency stop 24V	E-013-0015	221
Outflow plate TMD Flex/TM8FC magazine	L-014-0408	95	Relay type 40.52	K-017-0059	137
Outflow spring	D-014-0698-4	109	Relay type 55.34	K-017-0051	137
P4-CP2 complete with front	L-019-0058	34	Retainer board spring	D-025-0488B	50
			Retainer tool	D-012-0931	171
			Retrofit XWB3 + motors	L-012-0054	237
			RGB monitor cable 1	L-019-0519	15
			RGB monitor cable 2	L-019-0520	16

## Alphabetical Index

Product name	Part no.	Page	Product name	Part no.	Page
Rocker switch, E56-SW-2	K-017-0177	140	Signal interface	K-017-0167	141
Roller, cable tensioner	L-015-0327	245	Silencer spare part kit	L-022-0137	149
RS232 DSUB25M modular 6/6 adapter	L-019-0481	12	Silicon tube 3.5x8	K-012-0030B	198
RS 232 modular cable	L-019-0482	16	SKB3 keyboard board	L-019-0045-2	121
Rubber cloth 40 x 40 x 1 mm	K-012-0013	127	SKB3 key-tops, Danish	L-019-0493-DA	12
Ruler with reference line	L-010-0806	203	SKB3 key-tops, Dutch	L-019-0493-DU	12
Runner 6*19	K-024-0032	184	SKB3 key-tops, English	L-019-0493-EN	12
Run-time clock	K-019-0222	161	SKB3 key-tops, Finnish	L-019-0493-FI	12
Run-time clock 117V, 60Hz	K-019-0130-B	158	SKB3 key-tops, French	L-019-0493-FR	12
Run-time clock 220V 50Hz	K-019-0130	158	SKB3 key-tops, German	L-019-0493-GE	12
Safety Button	E-011-0026	116	SKB3 key-tops, Italian	L-019-0493-IT	13
Safety Button	E-011-0026	116	SKB3 key-tops, Norwegian	L-019-0493-NO	13
Safety clamp - ALM1216	L-014-1544	105	SKB3 key-tops, Spanish	L-019-0493-SP	13
Safety clamp - ALM8	L-014-1534	106	SKB3 key-tops, Swedish	L-019-0493-SW	13
Safety extension in / TEX	L-029-0397	178	SKB4-box cable	L-029-0006	118
Safety extension out / TEX	L-029-0398	179	SKB4 keyboard	L-029-0003-1B	121
Safety loop extension cable	L-049-0113	16	SKB4 key-tops, Danish	L-029-0318-DE	13
Safety Loop Extension cable	L-029-0399	179	SKB4 key-tops, Dutch	L-029-0318-DU	13
Safety Loop Extension end plug	L-029-0400	183	SKB4 key-tops, English	L-029-0318-EN	13
Safety Manual, MY Series & TP Series,	P020-0016-MB	57	SKB4 key-tops, Finnish	L-029-0318-FI	13
Safety reflex sensor	K-017-0072	137	SKB4 key-tops, French	L-029-0318-FR	13
Safety switch	E-011-0010	117	SKB4 key-tops, German	L-029-0318-GE	13
Safety switch contact block	E-011-0012	116	SKB4 key-tops, Italian	L-029-0318-IT	13
Safety switch contact block	E-011-0013	116	SKB4 key-tops, Norwegian	L-029-0318-NO	13
Safety switch contact block	E-011-0012	116	SKB4 key-tops, Spanish	L-029-0318-SP	13
Safety switch contact block	E-011-0013	116	SKB4 key-tops, Swedish	L-029-0318-SW	13
Safety switch ELF3 flat key with cables	L-049-0441	121	SKB4-SKB4 cable	L-029-0007	118
Safety switch extension clip	E-011-0014	118	Slide part support kit	L-045-0441	44
Safety switch for hood	K-015-0084	240	Slide shoe	D-014-0026B-4	110
Safety switch for Y-wagon hood and TEX. Not for Pro-Line hoods.	L-024-0182	240	Slide strip, TEX	D-024-0118-3	185
Safety switch for Y-wagon hood and TEX. Not for Pro-Line hoods.	L-024-0182	240	Sliding list, container	D-014-0666-3	110
Safety switch front hood	L-045-0423	43	Sliding list bottom plate	D-014-0683-4	110
Safety switch plate	E-011-0011	116	Slit plate complete TM1216C	L-014-0219	95
Safety switch plate	E-011-0011	116	Slit plate complete TM12C	L-014-0217	96
Safety switch rear hood	L-045-0420	43	Slit plate complete TM16C	L-014-0218	96
Safety switch YWU hood	L-049-0252	240	Slit plate complete TM24D	L-014-0220	95
Scale cleaning wipes	K-035-0067	51	Slit plate complete TM5632D	L-014-0503	96
SCSI Board	K-049-0006	29	Slit plate complete TM8C	L-014-0113	96
Selector switch, E56-SW-4.4	K-017-0178	141	Slot sensor for index bar	K-017-0067	138
Sensor holder model 2	L-019-0640	50	SLS	L-019-0226-1	53
Sensor lens FU-12	K-045-0039	51	SLS2 ed 1	L-019-0862-1	54
Sensor WT150-P162	K-017-0087	137	SMEMA-adapter	L-019-0778	39
Sensor WT170-P112	K-017-0086	138	SMEMA-adapter	L-019-0777	39
Set of 3 C14 tool tips	L-012-0823	154	Smema CPC14P - CPC14P cable	L-019-0865	39
Set of 3 B12 tool tips	L-012-0885	154	SMEMA CPC14P dummy connector	L-019-0866	42
SFB filter board elmobox	L-029-0320-3	233	SMEMA-in, cable	L-019-0521	36
Shaft coupling	K-015-0058	243	SMEMA-out, cable	L-019-0522	36
Shaft coupling 12/14	K-015-0055	243	SNB serial number board	L-019-0159	21
Shaft lower Flex magazine	D-014-0774-3	109	Soleniod unit	L-014-1567	106
SHIMS 1	D-015-1554	124	Solenoid complete HYDRA	L-012-0436	130
SHIMS 2	D-015-1553	124	Solenoid unit TM8C	L-014-0090C	69
SHIMS 3	D-015-1552	124	Spacer for TM12C feeder wheel	D-014-0858-3	81
Shock absorber Weforma	K-043-0007	120	Spacer for TM16C feeder wheel	D-014-0859-3	82
Shock absorber Weforma	K-043-0010	230	Spacer for TM24C feeder wheel	D-014-0860-3	82
Shock arbsorber Weforma	K-013-0035	230	Spacer for TM24D feeder wheel	D-014-1057-3	82
Shuttle, TEX Shuttle Unit	L-024-0108	185	Spacer for TM8C feeder wheel	D-014-0853B-3	82
Side plate, feeder unit - left	L-014-0121	66	Spare part kit 1 MY with Midas	L-040-0152	176
Side plate, feeder unit - right	L-014-0120	66	Spare part kit Membrane Pump	L-010-0708	196
Side Plate Flex Magazine - Left	L-014-0307	65	Spare part kit Tandem Pump	L-010-0709	196
Side Plate Flex Magazine - Right	L-014-0308	66	Spare Part Set 1B TP12/18-UFP	L-020-0030B	175
			Spare Part Set 1B TP9/11-UFP	L-010-0330B	175
			Spare Part Set 1F TP9-1/TP9-2	L-010-0030F	174
			Spare Part Set 1 MY-Series	L-040-0034	176
			Spare Part Set 1 TP9/11-UFP	L-010-0360	175
			Spare Part Set 1 TP9-2U	L-010-0361	174

## Alphabetical Index

Product name	Part no.	Page	Product name	Part no.	Page
Spare Part Set 2 MY with Midas	L-040-0153	176	Tempered glass 12X	D-041-0323	120
Spare screw kit small	L-045-0415	44	Tempered glass 3X	D-041-0280	121
Spare screw kit T3/T4	L-045-0550	44	Tempered glass 5X	D-041-0141	121
Spare screw kit T5/T6	L-045-0414	45	Tempered glass 9X	D-041-0142	121
Spring Clip, TEX Cassette	K-024-0037	110	TEX Barcodes 16 Jedec pallet	L-024-0188	178
Spring holder for conveyor	L-015-0069	50	TEX Bar codes 16 narrow pallet	L-024-0178	178
Spring package 500T2 special left	L-025-0192	45	TEX Bar codes 16 wide pallet	L-024-0179	178
Spring package 500T2 special left	L-025-0194	45	TEXBMCB, TEX BM Con. board	L-029-0319-3	187
Spring package 500T2 special right	L-025-0195	45	TEXLB, TEX LED Board	L-029-0334-2	187
Spring package 500T2 special right	L-025-0193	45	TEXYB, TEX Y Board	L-029-0335-3	187
Spring Tool Bank	D-015-1409	124	TEXZB, TEX Z Board	L-029-0323-3B	187
Spring Tool Bank PT	D-015-1406	124	Theta motor unit	L-012-0440B	128
Square axle	D-045-0628	51	Thin components in box	L-012-0622	24
Steel axle with ball bushing	U-015-0006-3	243	THS with holder	L-024-0028	187
Steel axle with ball bushing	U-015-0005	243	TMC tape solenoid con. board	L-019-0197-2	69
Steel belt centering upgrade	L-012-0057	9	Toner for OKI B4300/B4350	K-040-0194	153
Steel belt cover C-60	D-022-0122-3	6	Toner OKI 14i	K-040-0133	153
Stepper motor controller board	K-017-0106	43	Tool, Exchangeable, set of 8	L-012-0512	126
Stepper motor with brake	K-017-0085	143	Tool for motor exchange, C-60	L-007-0002	171
Stops, spare part kit	L-012-0522	126	Tool for steel-belt exchange	L-007-0003	171
SUNX EX14A reflex sensor	E-040-0159	43	Tool H04 spare tips	L-012-0576	127
Support beam complete	L-014-0124	93	Tool tip A12, PEEK	D-012-0263D-4	154
Support plate	L-025-0040B	188	Tool tip A13	D-012-1162	154
Support plate, conveyor	L-015-0064	51	Tool tip A14, Black PEEK	D-012-0408B	154
Support spring Flex	D-014-1132-4	110	Tool tip A23S	L-012-0540	155
Switch with light	K-017-0104	138	Tool tip A24S	L-012-0542	155
T3/T4 hood safety switch	L-045-0564	55	Tool tip A34, Black PEEK	D-012-0308C	155
T3/T4 lift motor 1	L-045-0560	53	Tool tip B23, Black PEEK	D-012-0248D	155
T3/T4 lift motor 2	L-045-0561	53	Tool tip B24, Black PEEK	D-012-0255D	156
T3/T4 transport motor	L-045-0562	53	Tool tip B34, Black PEEK	D-012-0404C	156
T3/T4 width motor	L-045-0563	53	Tool tip C14, Black PEEK	D-012-0282B-4	156
T3 cylindrical pin guide kit	L-045-0650	45	Tool tip C23S	L-012-0381B	156
T3 drive belt kit	L-045-0556	46	Tool Tip HYDRA, 10-pcs	L-012-0378	126
T3 Gable top kit	L-045-0552	46	Tool tip MELF 3.3	D-012-0857	157
T3 lift edge kit	L-045-0558	46	Tool tip MELF 4.5	D-012-0879	157
T4 drive belt kit	L-045-0555	46	Tool tip MELF 7.7	D-012-0284-4	157
T4 Gable top	L-045-0551	46	Torsion spring kit	L-045-0649	47
T4 lift edge kit	L-045-0557	46	TP9 Calibration board	L-019-0328-2	169
T4 transport belt kit	L-045-0553	46	TPSys 2.0 software kit	L-010-0734D	172
T5/T6 motor	L-045-0435	53	TPSys 2.1 software kit	L-010-0748B	172
T5 drive belt kit	L-045-0431	46	TPSys 2.2 software kit	L-010-0795E	172
T5 gable top kit	L-045-0426	47	TPSys 2.3.4 software kit	L-010-0810D	172
T5 Lift edge kit	L-045-0439	47	TPSys 2.3 Operator's manual	P-020-0014-EN	57
T5 transport belt	L-045-0436	38	TPSys 2.3 Programming manual	P-020-0015-EN	57
T6 drive belt kit	L-045-0429	47	TPSys 2.3 Software manual	P-010-0779-EN	57
T6 gable top kit	L-045-0440	47	TPSys 2.4 Operator's manual - Dutch	P-020-0023-NL	56
T6 Lift edge kit	L-045-0433	47	TPSys 2.4 Operator's manual - English	P-020-0023-EN	56
T6 transport belt	L-045-0430	38	TPSys 2.4 Operator's manual - Finnish	P-020-0023-FI	56
Tandem vacuum pump	L-019-0714	193	TPSys 2.4 Operator's manual - French	P-020-0023-FR	56
Tape guide plate	D-014-0685-2	95	TPSys 2.4 Operator's manual - German	P-020-0023-DE	56
Tape guide plate	D-014-0685B-2	95	TPSys 2.4 Operator's manual - Italian	P-020-0023-IT	56
Tape guide TM5632D	L-014-0502	110	TPSys 2.4 Operator's Manual - Japanese	P-020-0023-JA	56
Tape holder arm, Flex 12mm	L-014-0431	97	TPSys 2.4 Operator's manual - Portuguese	P-020-0023-PT	56
Tape holder arm, Flex 24mm	L-014-0911	97	TPSys 2.4 Programming manual - English	P-020-0024-EN	56
Tape holder arm, Flex 32mm	L-014-0650	97	TPSys 2.4 Programming manual - Finnish	P-020-0024-FI	56
Tape holder arm, Flex 44mm	L-014-0718	97	TPSys 2.4 Programming manual - French	P-020-0024-FR	56
Tape holder arm, Flex 56mm	L-014-0657	97			
Tape holder arm TM12C	L-014-0214	85			
Tape holder arm TM16C	L-014-0215	85			
Tape holder arm TM24D	L-014-0216	85			
Tape holder arm TM8C	L-014-0114	85			
Tape holder arm TM8FC	L-014-0446	85			
Tape support - ALM8	L-014-1547	106			
TBB tray box board	L-019-0421-1	186			
TCB	L-019-0486-1	8			



## Alphabetical Index

Product name	Part no.	Page	Product name	Part no.	Page
TPSys 2.4 Programming manual - German	P-020-0024-DE	56	Uncover wheel arm TM32D	L-014-0279	111
TPSys 2.4 Programming manual - Italian	P-020-0024-IT	56	Uncover wheel arm TM44D	L-014-0510	77
TPSys 2.4 Programming manual - Japanese	P-020-0024-JA	56	Uncover wheel arm TM56D	L-014-0514	77
TPSys 2.4 software kit	L-010-0849	172	Uncover wheel arm TM8C	L-014-0095C	77
TPSys 2.4 Software manual	P-010-0814-EN	57	Uncover wheel string	L-014-0518	78
TPSys 2.5 machine manual	P-020-0027-EN	57	Uncover wheel TM12C	L-014-0141	78
TPSys 2.5 Operator's manual - English	P-020-0025-EN	56	Uncover wheel TM16C	L-014-0142	78
TPSys 2.5 Operator's manual - Finnish	P-020-0025-FI	56	Uncover wheel TM24D	L-014-0143	78
TPSys 2.5 Operator's manual - French	P-020-0025-FR	56	Uncover wheel TM32D	L-014-0280	78
TPSys 2.5 Operator's manual - German	P-020-0025-DE	56	Uncover wheel TM44D	L-014-0804	78
TPSys 2.5 Operator's manual - Italian	P-020-0025-IT	56	Uncover wheel TM56D	L-014-0805	79
TPSys 2.5 Operator's manual - Spanish	P-020-0025-ES	56	Uncover wheel TM8C	L-014-0096	79
TPSys 2.5 Programming manual	P-020-0026-EN	57	Uncover wheel TM8C, plastic	L-014-0460	79
TPSys 2.5 software kit	L-010-0868	172	Unloading position sensor	L-029-0127	179
TPSys 2.5 Software manual	P-020-0028-EN	58	Upgrade for membrane pump	L-012-0101	198
Trackball	K-019-0384	11	Upgrade for membrane pump	L-012-0100	199
Trackball with emergency button	L-049-0085B	12	Upgrade HZ motor Hydra	L-012-0809	128
Transducer bracket	D-013-0172-3	227	Upgrade kit 2.5" HD	L-019-1155	34
Transducer with cables YWU	L-015-0423	240	Upgrade kit barcode reader	L-024-0180	106
Transformer	K-017-0169	138	Upgrade kit BJS	L-015-0451	55
Transport belt diameter 4mm	K-017-0053	133	Upgrade kit cable wagon TP12	L-023-0039	212
Transport Belt GT6 19*1850	K-017-0093	133	Upgrade kit cable wagon TP18	L-023-0038	212
Transport Belt GT6 19*2050	K-017-0088	133	Upgrade kit vacuum valve	L-012-0370	193
Transport Belt GT6 19*2200	K-017-0097	134	Upgrade X axis to single belt	L-013-0016B	237
Transport Belt GT6 19*2450	K-017-0094	134	Upgrade X Wagon camera	L-012-0074	207
Transport Belt GT6 19*3050	K-017-0089	134	UPS EBK-350 with plastic feet	L-049-0661	165
Transport Belt GT6 19*3450	K-017-0095	134	UPS for PC server 120VAC	L-019-1107	158
Transport Belt GT6 19*3650	K-017-0090	134	UPS for PC server 230VAC	L-019-1106	158
Transport Belt GT6 19*4450	K-017-0096	135	UPS Powerware 3110 upgrade kit	L-049-0677	162
Transport Belt GT6 19*4650	K-017-0091	135	UPS replacement	L-049-0678	163
Transport Belt GT6 19*5650	K-017-0092	135	UPS-Server cable	L-049-0473	159
Transport Belt TT5/1-HC 18*2580	K-017-0098	135	UPS-Sever cable	L-049-0272	159
Tranzorb 24V 600W	SSTRANZ24V600	21	UPS spare part for Powerware 3110 with AT	L-049-0687	163
Tray contact sensor with cable	L-029-0123	179	UPS spare part with box 12V/5V	L-049-0608	163
Tray holder magnet with cable	L-029-0124	179	UPS spare part with box 12V/5V	L-049-0686	163
Tray stop solenoids with cable	L-029-0128	179	Vacuum filter	K-012-0016	198
TST2 spare part	L-049-0635	234	Vacuum filter HYDRA 100-pcs	K-012-0108	128
TST cable	L-019-0068	212	Vacuum filter pack	L-012-0628	128
TST ed. 1	L-019-0065-1	233	Vacuum filters and tubes	L-012-0104	196
Tube connector, T-230-1	K-012-0019	197	Vacuum seal spare part kit	L-022-0136	149
Tube connector, T-40-1	K-012-0018	198	Vacuum tank	K-012-0031	198
Tygaflor tape 24mm	U-023-0001	231	Vacuum tube	L-022-0120	150
ULN2065B darlington driver	SHULN2065B	22	Vacuum tube with cable	L-012-0073B	253
Uncover roller complete	L-014-0101	91	Vacuum tube with Z-sensor	L-029-0199B	250
Uncover roller coverage	L-014-0103	114	Vacuum Unit	L-012-0609	130
Uncover wheel, Flex 12mm	L-014-0405	97	Vacuum valve (MAC)	K-012-0084	191
Uncover wheel, Flex 24mm	L-014-0430	97	Valve monst.	K-017-0219	143
Uncover wheel, Flex 32mm	L-014-0899	97	Valve Rocker arm	D-025-0216-4	51
Uncover wheel, Flex 44mm	L-014-0900	97	Washer 0.025 mm	K-041-0022	97
Uncover wheel, Flex 56mm	L-014-0901	97	Washer 0.2 mm	K-041-0021	97
Uncover wheel arm, Flex 12mm	L-014-0404	97	Waste shelf	L-014-1621	114
Uncover wheel arm, Flex 16mm	L-014-0409	97	VC board for GFI	L-019-1110	112
Uncover wheel arm, Flex 24 mm	L-014-0427	97	VC edition 4B, Vibration Control	L-019-0039-4B	113
Uncover wheel arm, Flex 8mm	L-014-0407	97	VGA-VGA Adaptor Cable for VVG2	L-049-0175	16
Uncover wheel arm TM12C,16C	L-014-0138	77	VGA Video board	K-019-0210B	29
Uncover wheel arm TM24D	L-014-0140	77	Vibrator	K-014-0012B	101
Uncover wheel arm TM32D	L-014-0279	111	Video camera, CCD XC-77BBCE	K-019-0170B	201
			Video camera, Sony CCD XC-77CE	K-019-0170	211
			Video Multi-plexer	K-019-0187B	29
			Window holder	L-010-0425	203
			WSR2 cable	L-019-0506	213
			WSR2 edition 5B	L-029-0036-5B	234
			WSR cable	L-019-0067B	213
			WSR X-safety switch receiver	L-019-0063-5C	234

## Alphabetical Index

Product name	Part no.	Page	Product name	Part no.	Page
WSR-XVS cable kit	L-049-0428	213	XMIBUS cable left, inner	L-029-0099	99
VVG2 edition 2C with 4MB	L-019-0827-2C	30	XMIBUS cable left, outer	L-029-0100	99
X/Y emergency cables	L-019-0182C	119	XMIBUS cable right	L-029-0104	99
X24C02P DIL-8	SHX24C02	183	XMIBUS cable right, inner	L-029-0101	99
X-belt	K-013-0032	212	XMIBUS cable right, outer	L-029-0102	100
X-belt	K-013-0023	212	XMIF2 cable	L-049-0062	100
X-belt bearing housing, left	L-013-0014C	227	XMIF cable	L-019-0093B	100
X-belt bearing housing, right	L-013-0013C	228	X-motor with cogwheel	L-019-0195	232
X-belt motor	K-013-0031B	231	XMS motor & sensor cable	L-019-0205	93
X-belt motor	K-013-0026	231	XM XO-X6 cable	L-019-0732	180
X-belt motor kit	L-043-0067	231	XM XO-X6 cable	L-019-0732	180
X-belt motor with transducer	L-013-0113	237	XNET voltage 100V	L-029-0361-2	158
XBMC belt motor cable	L-019-0544	213	XNET voltage 110V	L-029-0358-2	158
XBOF booster flat cable	L-019-0410	213	XNET voltage 115V	L-029-0359-2	158
XBOF Booster flat cable	L-019-0077	213	XNET voltage 125V	L-029-0360-3	158
XBOF Booster Power cable / TEX	L-029-0379	179	XNET voltage 175/100V	L-029-0293-1	158
XBOF M-Booster flat cable	L-049-0012	159	XNET voltage 190/110V	L-029-0292-1	158
XBOP Booster power cable	L-019-0072	214	XNET voltage 200/115V	L-029-0289-3	158
XBOP Booster power cable	L-019-0409	214	XNET voltage 210/121V	L-029-0288-3	158
XBOP Booster Power cable	L-029-0380	180	XNET voltage 215/125V	L-029-0428-1	158
XCCP centering camera cable	L-019-0442	214	XNET voltage 220/127V	L-029-0290-1	158
XCLP cent. lamp power cable	L-019-0441	201	XNET voltage 225/130V	L-029-0427-1	158
XCMC C-motor cable	L-029-0149	6	XNET voltage 230/133V	L-029-0426-1	158
XCP crude power cable	L-019-0071	214	XNET voltage 235/136V	L-029-0425-1	158
XCP crude power cable	L-019-0408	214	XNET voltage 240/140V	L-029-0424-1	158
XCP Crude Power cable	L-029-0381	180	XNET voltage 250/145V	L-029-0423-1	158
XCR21 monitor cable TP9-BNC	L-019-0102	16	XNET voltage 345/200V	L-029-0422-1	158
XCR21 Monitor cable TP9-BNC	L-019-0415	16	XNET voltage 365/210V	L-029-0362-1	158
XCR22 Monitor cable BNC-BNC	L-019-0103	17	XNET voltage 370/215V	L-029-0287-1	158
XDD1 Cable	L-049-0125	17	XNET voltage 380/220V	L-029-0286-1	158
XDDP1 diskdrive cable	L-019-0765	18	XNET voltage 390/225V	L-029-0285-1	158
XDDP diskdrive cable	L-019-0801	17	XNET voltage 400/230V	L-029-0284-3	158
XDDP diskdrive cable	L-019-0620	17	XNET voltage 410/235V	L-029-0291-1	158
XDDP diskdrive cable	L-029-0050B	18	XNET voltage 415/240V	L-029-0283-3	158
XDDP disk drive cable	L-029-0347	17	XNET voltage 435/250V	L-029-0282-1	158
XDDP disk drive cable A:5,25	L-019-0473	17	XOCAT OCL & video cable	L-019-0499B	19
XDM drive magnets cable	L-019-0206	93	XOCP-1 opt. cent. power cable 1	L-019-0470B	19
XDSS Door Safety Switch cable	L-029-0383B	180	XOCP-2 opt. cent. power cable 2	L-019-0471	19
XDY diskette cable in Y Wagon	L-019-0416	18	XP2 TST2 sync. cable	L-029-0200B	215
XETC ELMO timer cable	L-019-0658	215	XP2 TST2 sync. cable	L-029-0201B	215
XFAN Fan with cable	L-019-0397	24	XPD disk power & data cable	L-019-0092	19
XFIM Fi motor cable	L-019-0204C	253	XPD disk power & data cable	L-019-0413	19
XFL board position sensor	L-019-0253	39	XPOA-OCL cable	L-019-0315	19
XFMB Fi motor board cable	L-029-0193	149	XPOW1 Cable	L-049-0123	20
XFT-board position sensor	L-019-0252	18	X-rail cleaner	D-012-0270-4	231
XGTS connection block cable	L-019-0505	40	X-rail profile, lower	D-011-0083-4	228
XHYD HYDB-XWB3 cable	L-049-0424B	124	X-rail profile, upper	D-011-0087-3	228
XLED cable / TEX	L-029-0391	180	XSKB keyboard cable	L-019-0424	20
XMEB edition 4	L-029-0179-4	234	XSP safety sensor and switch	L-029-0164	180
XMF1 glue cable 1	L-049-0016	118	XSS edition 3	L-029-0367-3	234
XMF2 glue station cable	L-019-0632	122	XTC cable	L-029-0150B	6
XMFC YWU3 conveyor cable	L-019-0842B	40	XTC electrodes with cables	L-019-0490	8
XMFE2 Y Wagon cable	L-029-0089	40	XTC for belt centering unit	L-019-0081C	8
XMFE conveyor cable	L-019-0239B	40	XTF cable	L-019-0456	215
XMF glue cable	L-019-0412	122	XTF VMF trafo cable	L-019-0139	101
XMF glue cable	L-019-0099	122	XTP two/three test cable	L-019-0084	7
XMF glue station adapter cable	L-019-0631	122	XTYBO TEX Y Booster2 cable	L-029-0403	181
XMIB4 cable	L-049-0232	98	XTY-Z TEX Y Wagon Z-unit cable	L-029-0388	180
XMIBOX cable	L-019-0094	98	XTZU cable / TEX	L-029-0382	181
XMIBOX cable	L-019-0529	98	XV4L lamp cable	L-019-0303B	201
XMIBOX cable	L-019-0414	98	XV4L video lamp cable	L-029-0194	201
XMIBUS cable	L-019-0095B	98	X-wagon camera spare part kit	L-012-0815	209
XMIBUS cable	L-019-0527B	98	X-wagon encoder kit	L-043-0104	224
XMIBUS cable, middle	L-029-0098	100	X Wagon motor	L-019-0462	232
XMIBUS cable left	L-029-0103	99	X Wagon motor	L-029-0024	232

## Alphabetical Index

Product name	Part no.	Page	Product name	Part no.	Page
X Wagon motor complete	L-049-0118	209	YM grease	L-045-0427	241
X Wagon motor connector	L-049-0091	231	YM linear encoder	L-045-0421	241
X-wagon motor MY refurbished	L-049-0698	232	YM linear scale cleaning kit	L-045-0428	241
XWB3 X Wagon board 3	L-029-0276-3B	207	YM linear scale replacement kit	L-045-0422	241
XVC camera cable	L-029-0153	215	Y-transducer with cable	L-019-0087B	240
XWMB2	L-029-0180-2	234	Y Wagon motor	U-015-0008	244
XVS vacuum system cable	L-029-0195C	195	Y Wagon motor filter box cable	L-019-0295B	244
XVS vacuum system cable	L-019-0275D	196	YWB2 Y Wagon board 2	L-019-0734-1	245
XXFS fan sensor cable	L-029-0041	215	YWB Y Wagon board	L-019-0025-6	245
XXME X-motor transducer	L-029-0232	221	ZFIB spare part kit	L-049-0685	149
XXME X-motor transducer	L-049-0120B	222	Z-Fi unit complete	L-012-0037B	253
XXME X-motor transducer	L-019-0619B	222	Z-Fi unit with motors	L-022-0050	247
XXME X-motor transducer	L-019-0464	222	Z-Fi unit without motors	L-012-0056B	253
XXW1-2, XXW3 50 pole cable	L-029-0011	217	Z-Fi unit without motors	L-022-0066	247
XXW1-2 50 pole cable	L-049-0033	216	Z-gear shaft	L-012-0043	255
XXW1-2 50 pole cable	L-019-0525	216	Z-head washer	D-012-0424-4	255
XXW1-2 50 pole cable	L-019-0455	216	Z-lock bracket with magnets	L-022-0065B	247
XXW1-2 X Wagon cable	L-049-0166	216	Z-lock bracket with magnets	L-022-0065B	247
XXW1-2 X Wagon cable	L-049-0035	216	Z-lock cable with solenoids	L-029-0191B	253
XXW1-2 X Wagon cable	L-049-0168	217	Z-lock cable with solenoids	L-029-0191B	253
XXW1 cable 50 pole	L-019-0407	217	Z-lock reinforcement	D-022-0102B-4	251
XXW1 cable 50 pole sectioned	L-019-0078B	217	Z-middle axis complete	L-022-0073	250
XXW2-2, XXW4 40 pole cable	L-029-0012	217	Z-motor, Midas	L-022-0105B	147
XXW2A+B - 2 X wagon cable	L-049-0034	218	Z-motor 1 with encoder	L-029-0157B	250
XXW2A+B 60 pole cable	L-019-0526	218	Z-motor 2	L-029-0158	250
XXW2A+B 60 pole cable	L-019-0450	218	Z-Motor and Brake cable / TEX	L-029-0395	181
XXW2A+B X Wagon cable	L-049-0169	219	Z-Motor with cable for TE	L-029-0166	185
XXW2A+B X Wagon cable	L-049-0036	219	Z motor with encoder	L-019-0004B	255
XXW2A+B X Wagon cable	L-049-0167	219	Z motor with encoder	L-019-0004B	255
XXW2 cable 40 pole	L-019-0406	218			
XXW2 cable 40 pole sectioned	L-019-0079B	218			
XXWT X-motor transducer	L-019-0297B	222			
XXWT X-motor transducer	L-019-0759B	222			
XXWT X Wagon transducer	L-029-0231B	209			
XXWT X Wagon transducer	L-019-0075E	222			
XXWT X Wagon transducer	L-019-0618	223			
XXWT X Wagon transducer	L-019-0460	223			
XY/D DELTA connection	L-029-0297	161			
XY/D DELTA connection	L-029-0296-3	161			
XY/D WYE connection	L-029-0295-3	161			
XYBO/80V Y Booster2 80V 0.56 ohm cable	L-019-0772	20			
XYCM Y motor extension cable	L-019-0287	40			
XYF2 Y Wagon flat cable 2	L-019-0726	239			
XYF2 Y Wagon flat cable 2	L-019-0725	239			
XYFA Y wagon cable adapter YWB	L-019-0727	239			
XYFI Y Wagon flat cable int.	L-019-0831	239			
XYF Y Wagon flat cable	L-029-0055	40			
XYF Y Wagon flat cable	L-019-0411	238			
XYM motor connector cable	L-019-0500	181			
XYM motor extension cable	L-019-0507	181			
XYM TEX Y-Motor cable	L-029-0384	181			
XYWH Y-width end position switch	L-019-0251	52			
XZBO/80V Z Booster2 80V 1ohm cable	L-019-0771	20			
XZFG Z-Fi ground cable	L-029-0409	254			
XZH Z-lock cable with bracket	L-019-0100B	254			
YC edition 6	L-019-0225-6	54			
Y-conveyor flat cable	L-019-0255	41			
YM amplifier	L-045-0424	240			
YM cable chain	L-045-0418	241			
YM control board	L-045-0425	47			
YM crash protection kit	L-045-0417	241			
YM fan kit	L-045-0413	48			
YMFC conveyor cable	L-019-0843	41			



Online catalog  
[www.mydata.com](http://www.mydata.com)

**SWEDEN**

MYDATA automation AB  
Adolfsbergsvägen 11  
168 66 Bromma  
Sweden  
Tel: +46 8 475 55 00  
Fax: +46 8 475 55 01

**USA**

MYDATA automation, Inc.  
320 Newburyport Turnpike  
Rowley MA 01969-2002  
USA  
Tel: +1 978 948 6919  
Fax: +1 978 948 6915

**JAPAN**

MYDATA automation KK  
Sumitomo Rokko Building 1st floor  
1-4-1, Shinkawa, Chuo-ku,  
Tokyo, 104-0033  
Japan  
Tel: +81 3 3553 5053  
Fax: +81 3 3553 5051

**UK**

MYDATA automation Ltd.  
14 Wessex Trade Centre  
Ringwood Road  
Poole BH12 3PQ  
England  
Tel: +44 1202 723 585  
Fax: +44 1202 723 269

**CHINA**

MYDATA automation Pte Ltd.  
Shanghai representative office  
Block 4, No. 700 Gui Ping Road,  
Cao He Jing Hi-Tech Park,  
Shanghai 200233, China  
Tel: +86 21 6485 5389

**BENELUX**

MYDATA automation B.V.  
Schakelplein 10  
5651 GR Eindhoven  
Netherlands  
Tel: +31 40 262 06 67  
Fax: +31 40 262 06 68

**MYDATA automation Pte Ltd.**

Shop 206, Dong Bao House,  
Yee Hong Road, Yee On Industrial City,  
Yantain, Feng Gang Town, Dongguan,  
Guangdong, China  
Tel: +86 769 7567 313  
Fax: +86 769 7568 152

**FRANCE**

MYDATA automation S.A.  
13 Rue de Norvège BP122  
91944 Courtaboeuf Cedex  
France  
Tel: +33 1 69 59 24 34  
Fax: +33 1 69 28 71 00

**SINGAPORE**

MYDATA Asia Pte Ltd.  
Asiawide Industrial Building  
5 Pereira Road, #01-01  
Singapore 368 025  
Tel: +65 6281 7997  
Fax: +65 6281 7667

[www.mydata.com](http://www.mydata.com)  
[info@mydata.se](mailto:info@mydata.se)