

Reinforced frame module

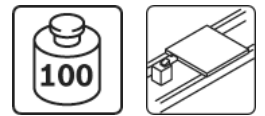

- For self-assembly of workpiece pallets measuring 400 x 400 mm and above. Necessary for overall weights of workpiece pallets $m_W > 50$ kg and for conveying speeds $v_N > 12$ m/min
- 400 mm corner module

- 320 mm frame extension module
- Wide variety of workpiece pallet sizes can be achieved by combining standard modules
- Material:
 - Corner/extension module (PA) with PA (polyamide) wear pad
 - or
 - Corner/extension module (PA) with PE (= polyethylene) wear pad
- Can be combined with WT 2 carrying plates

Product description

Reinforced frame modules are used for self-assembly of workpiece pallets with dimensions from 400 x 400 mm. Necessary for workpiece pallet total weights > 50 kg or for conveyor speeds $v_N > 12$ m/min.

The PA basic solution is suitable for use on the belt/toothed belt and flat top chain conveyor media.

Frame modules with PE wear pads are required for use on the duplex chain and accumulation roller chain conveyor media.

Technical data

Width of workpiece pallet	Length of workpiece pallet	Plate mass	Plate mass	Plate mass	Dimension	Dimension	Dimension	Dimension
b_{WT}	l_{WT}	$m_{PL1)}$	$m_{PL2)}$	$m_{PL3)}$	c	d	e	f
(mm)	(mm)	(kg)	(kg)	(kg)	(mm)	(mm)	(mm)	(mm)
160	160	0,9			45	124	124	45
160	240	1,4			45	204	124	125
240	240	2,1			125	204	204	125
160	320	1,8			45	284	124	205
240	320	2,8			125	284	204	205
320	320	4,3	2,1		205	284	284	205
240	400	4,1	2,0		125	364	204	285
320	400	5,3	3,7		205	364	284	285
400	400	6,6	3,4	5,3	285	364	364	285
320	480	6,4	3,2	5,1	205	444	284	365
400	480	7,0	4,0	6,4	285	444	364	365
480	480	9,3	4,9	7,7	365	444	444	365
400	640	10,4	5,4	8,6	285	604	364	525
480	640	12,3	6,5	10,3	365	604	444	525
640	640	16,3	8,7	13,8	525	604	604	525
400	800			10,8	285	764	364	685
480	800			12,9	365	764	444	685
640	800			17,3	525	764	604	685
800	800			21,7	685	764	764	685
640	1040			22,5	525	1004	604	925
800	1040			28,2	685	1004	764	925
800	1200			36,0	685	1164	764	1085
1040	1040			40,6	925	1004	1004	925
1040	1200			46,9	925	1164	1004	1085
1200	1200			54,1	1085	1164	1164	1085

- 1) Steel 4.8 mm
- 2) Aluminum 8.0 mm
- 3) Aluminum 12.7 mm

WT 2: Frame modules with PE-wear pad – parts list

For workpiece carriers $m_W > 50$ kg or $v_N > 12$ m/min



b_{WT} (mm)	l_{WT} (mm)	3842526760 ²⁾	3842526761	3842526762	3842526763	3842526764	3842528292 ¹⁾
320	480	2		2			
400	400						4
400	480	2					2
400	640			2			2
400	800	2				2	2
480	480	4					
480	640	2		2			
480	800	4				2	
640	640			4			
640	800	2		2		2	
640	1040			2	2	2	
800	800	4				4	
800	1040	2			2	4	
800	1200	2	2			6	
1040	1040				4	4	
1040	1200		2		2	6	
1200	1200		4			8	

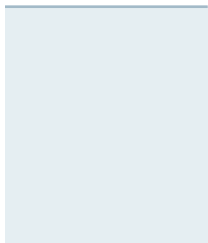

3842528293 ¹⁾
2
2
2
2
4
4
4
4
4
4
4
4
4
4
4

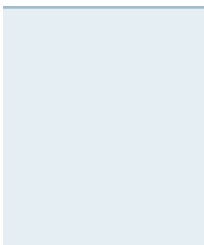

4

4

4

1) Reinforced module

2) With the 160 mm frame module with a PE wear pad (3842526760), no exciter plate is included for sensing with inductive sensors from below. Only lateral position inquiry is possible with this design.

WT 2: Frame modules with PE-wear pad – parts list

For workpiece carriers $m_W \leq 50$ kg or $v_N \leq 12$ m/min



b_{WT} (mm)	l_{WT} (mm)	3842526760 ²⁾	3842526761	3842526762	3842526763	3842526764
160	160	4				
160	240	2	2			
160	320	2		2		
240	240		4			
240	320		2	2		
240	400		2		2	
320	320			4		
320	400			2	2	
320	480	2		2		2
400	400				4	
400	480	2			2	2
400	640			2	2	2
400	800	2			2	4
480	480	4				4
480	640	2		2		4
480	800	4				6
640	640			4		4
640	800	2		2		6
640	1040			2	2	6
800	800	4				8
800	1040	2			2	8
800	1200	2	2			10
1040	1040				4	8
1040	1200		2		2	10
1200	1200		4			12

1) With the 160 mm frame module with a PE wear pad (3842526760), no exciter plate is included for sensing with inductive sensors from below. Only lateral position inquiry is possible with this design.

WT 2: Frame modules with PA-wear pad – parts list

For workpiece carriers $m_W > 50$ kg or $v_N > 12$ m/min



b_{WT} (mm)	l_{WT} (mm)	3842174301	3842174302	3842174303	3842174304	3842513458	3842525998 ¹⁾
320	480	2		2			
400	400						4
400	480	2					2
400	640			2			2
400	800	2				2	2
480	480	4					
480	640	2		2			
480	800	4				2	
640	640			4			
640	800	2		2		2	
640	1040			2	2	2	
800	800	4				4	
800	1040	2			2	4	
800	1200	2	2			6	
1040	1040				4	4	
1040	1200		2		2	6	
1200	1200		4			8	

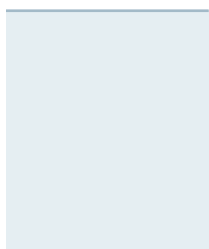

3842525999¹⁾

2

2

2

2

4

4

4

4

4

4

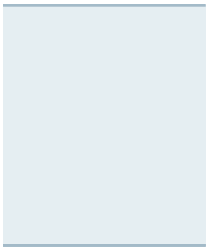

4

4

4

4

4

4

1) Reinforced module

WT 2: Frame modules with PA-wear pad – parts list

For workpiece carriers $m_W \leq 50 \text{ kg}$ or $v_N \leq 12 \text{ m/min}$



b_{WT} (mm)	l_{WT} (mm)	3842174301	3842174302	3842174303	3842174304	3842513458
160	160	4				
160	240	2	2			
160	320	2		2		
240	240		4			
240	320		2	2		
240	400		2		2	
320	320			4		
320	400			2	2	
320	480	2		2		2
400	400				4	
400	480	2			2	2
400	640			2	2	2
400	800	2			2	4
480	480	4				4
480	640	2		2		4
480	800	4				6
640	640			4		4
640	800	2		2		6
640	1040			2	2	6
800	800	4				8
800	1040	2			2	8
800	1200	2	2			10
1040	1040				4	8
1040	1200		2		2	10
1200	1200		4			12

Dimensions

WT 2 workpiece pallet, completely assembled

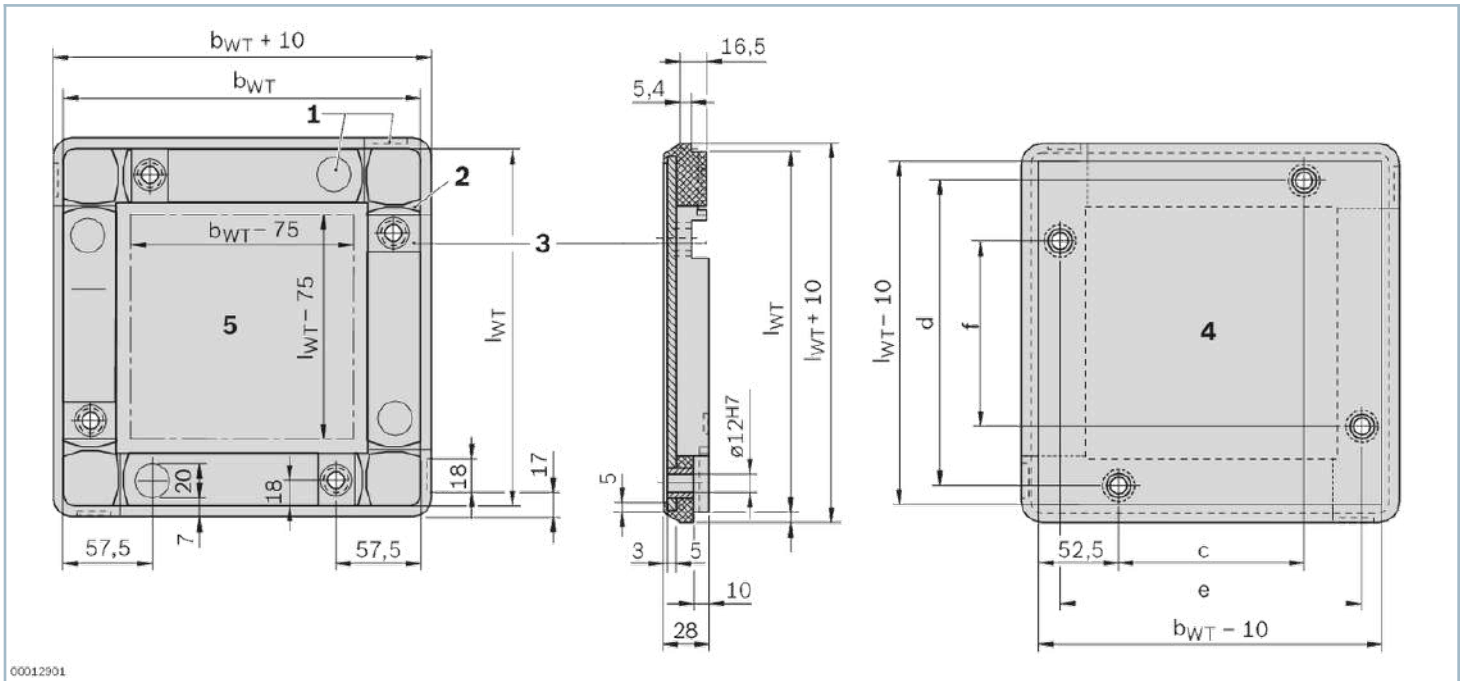

No production drawing

- 1 exciter plate
- 2 guide groove
- 3 stop gate aperture
- 4 top clearance
- 5 bottom clearance

Ordering codes

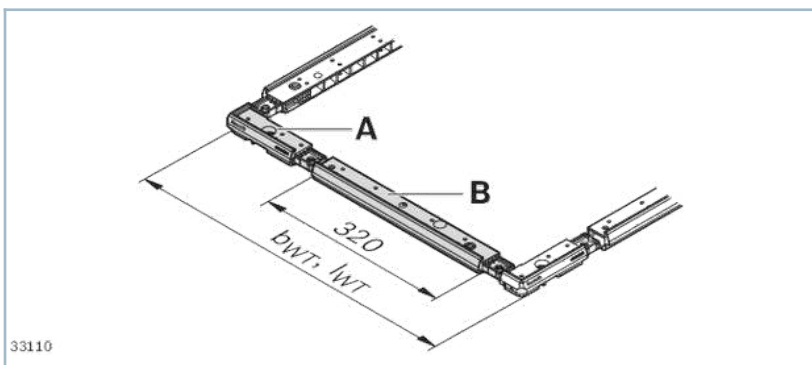

- 1) A: Corner module
- B: Extension module

	b_{WT}, l_{WT}	l	No.
	mm	mm	
Reinforced frame module, corner module (PA)	400		3842525998
Reinforced frame module, corner module (PA+PE)	400		3842528292
Reinforced frame module, extension module (PA)		320	3842525999

	b_{WT}, l_{WT}	l	No.
	mm	mm	
Reinforced frame module, extension module (PA+PE)		320	3842528293